

Marvin French Casemaster

Installing the Multi-Lock Handle and Hinge Adjustment



Installing Multi-Lock Handle

Note: The locking handle position in figure 1 is reversed for Round top units. Windows manufactured before 10/04 with backer plates require reusing the old backer plate to fasten the locking handle to the hardware cover rather than the mounting plate as shown in figure 2.

1. Insert the multi-lock handle through opening in the base of hardware cover and unlock sash by rotating the handle 180 degrees. See figure 1.

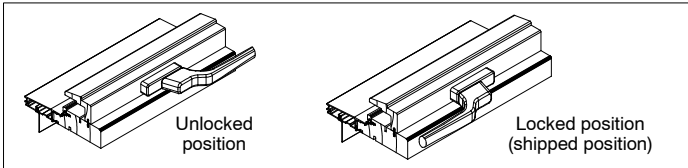

Figure 1

2. Remove screen, crank open both sash and remove the shipping blocks that are attached to the top and bottom of the sash.
3. Fasten the locking handle with two Phillips head machine screws inserted through the mounting bracket and hardware cover into the handle base as shown in figure 2.

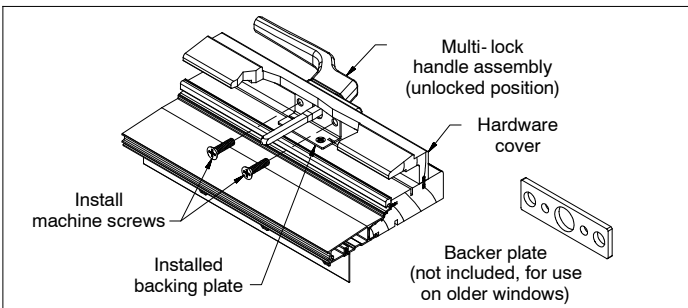

Figure 2

Adjusting Concealed Hinges

French Casemasters have an adjustment feature on the hinges to assist with aligning the sash to the frame. Aligning the sash to the frame will help the unit operate smoothly.

IMPORTANT: Adjustable hinges are not intended to compensate for an improperly installed unit.

NOTE: When adjusting hinges, try to maintain an equal reveal on both sash as shown in figure 3.

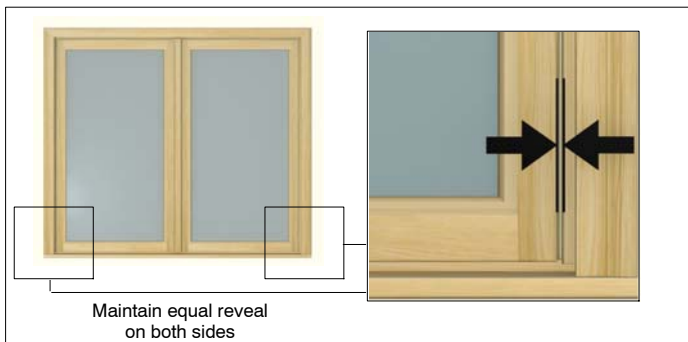

Figure 3

1. Place 3/8" adjustment wrench between hinge arm and hinge track as shown in figure 3. Clockwise movement will move sash away from jamb and counter-clockwise movement will move sash towards jamb as shown in figure 4.

NOTE: Top and bottom sash movement is independent. Adjust each hinge accordingly.



Figure 4

Multi-Lock Adjustment

1. To make the sash close tighter along the astragal, use a 7/16" adjustment wrench to move the adjustment mark on the locking cams toward the astragal. To make the sash lock easier, move the adjustment mark on the locking cams away from the astragal. There will be four to five roller cams located on the top, bottom, and meeting stile of the primary sash depending on unit size. See figure 5.

NOTE: Locking cams are adjusted using an open end wrench and moving the cams as described above.

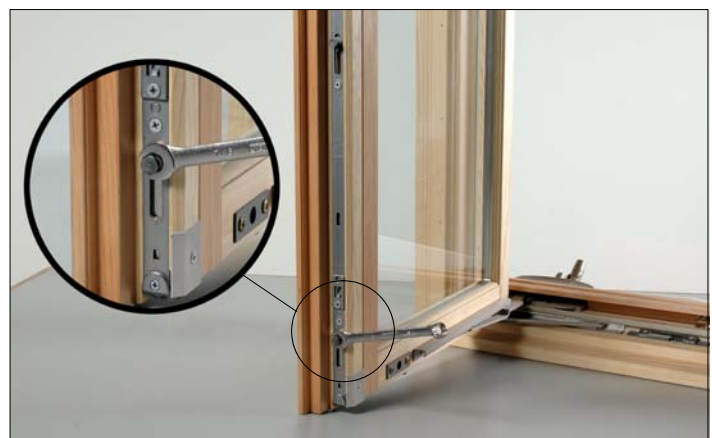

Figure 5