

Ultimate Bi-Fold Door

Installation Instruction

ABSTRACT: Please read these instructions in their entirety before beginning to install this product. This instruction shows the frame assembly and installation of an Ultimate Bi-fold door in new wood frame construction using an industry approved water management system. For installation using other construction methods, such as remodeling, replacement, and recessed openings refer to “ASTM E2112, Standard Practice for Installation of Exterior Windows, Doors and Skylights,” for installation suggestions. Information for ASTM E2112 can be found on the ASTM website, www.astm.org

Regional standard practices, environmental conditions, and codes may vary and supersede the procedures contained within. The responsibility for compliance is yours: the installer, inspector, and owner(s).

The procedures within these instructions are consistent with those used in testing to achieve the advertised DP rating.

Usage Dates: 4/2017 to present.

Table of Contents

Hazard Notations	2
Installer and Builder Information	3
After Market Products	3
You Will Need to Supply	3
Frame Assembly	4
Splicing Sills and Head Jambs	7
Sill Splicing	7
Splicing Head Jambs	8
Frame Installation	10
Hinge Installation	13
Hanger and Wall Pivot Adjustments	15
Panel Installation	17
Hinge/Handle Optional Installation	20
Final Component Installation	21
Stationary Panel Installation	25
Technical Installation Specifications	26

Hazard Notations

WARNING!

Always practice safety! Wear the appropriate eye, ear, and hand protection, especially when working with power tools.

WARNING!

This product can expose you to chemicals including titanium oxide, which is known to the state of California to cause cancer. For more information, go to www.P65Warnings.ca.gov.

WARNING!

This product can expose you to chemicals including methanol, which is known to the state of California to cause birth defects or other reproductive harm. For more information, go to www.P65Warnings.ca.gov.

WARNING!

Drilling, sawing, sanding or machining wood products can expose you to wood dust, a substance known to the State of California to cause cancer. Avoid inhaling wood dust or use a dust mask or other safeguards for personal protection. For more information go to www.P65Warnings.ca.gov/wood.

WARNING!

Older homes may contain lead-based paint, which may be disturbed when replacing windows or performing renovations. Consult state or local authorities for safe handling, disposal, or abatement requirements. For more information, go to www.epa.gov/lead.



Seek Assistance

Some large windows and/or assemblies are very heavy. Avoid injury by getting help to lift and position the unit into the rough opening.

IMPORTANT

Unfactored superimposed load (Live, Wind, or Snow) deflection over the entire length of the unsupported span cannot be greater than 1/8" (3) after natural sag of the beam and permanent loads are in place.

NOTE: Numbers listed in parentheses () are metric equivalents in millimeters rounded to the nearest whole number.

NOTE: Please consult local waste management authorities regarding proper disposal and/or recycling of all waste materials generated during installation, including any product being replaced, packaging materials, and other waste.

Installer and Builder Information

- Always provide a copy of these instructions for the current homeowner.
- Plan sizing of rough opening and clearance from exterior finishing systems to allow for normal materials shrinkage or shifting (e.g. wood structure with brick veneer; allow adequate clearance at the sill). Failure to do so can void the Marvin warranty coverage.
- Refer to the Technical Installation Specifications section for technical specifications regarding the installation of this product. These installation requirements as well as the details in the section must be followed to achieve the advertised design pressure (DP) rating of this product.
- It is the responsibility of the builder, installer, and subcontractors to protect the interior and exterior of windows or doors from contact with harsh chemical washes, construction material contamination and moisture. Damage to glazing, hardware, weather strip and cladding/wood can occur. Protect with painters tape and/or protective sheathing as required. Follow all guidelines regarding material use, preparation, personal safety and disposal.
- Refer to the enclosed painting and staining instructions for exterior and interior finish instructions.
- Contact your Marvin supplier if you have any questions regarding product and materials used in manufacturing or questions on replacement parts.
- Please refer to the PDF version of this instruction for further information regarding best practices installer and builder information, code, and other legal requirements. The PDF version is the official document of record.

After Market Products

Alterations to Marvin products including window films, insulating or reflective interior window treatments or additional glazings can cause excessive heat buildup and/or condensation. They may lead to premature failures not covered under warranty by Marvin Windows and Doors.

Before purchasing or applying any product that may affect the installation or performance of Marvin windows or doors, contact the manufacturer of after-market product/glazings that are not supplied by Marvin and request written product use, associated warranties and damage coverage. Provide this information and warranties to the end user and/or building owner for future reference.

You Will Need to Supply

- Safety Glasses
- Hearing protection
- Level and/or laser
- Square
- Hammer
- Composite shims
- 2" Roofing nails
- Insulation
- Tape measure
- Perimeter sealant
- Sill pan flashing
- Backing material (foam backing rod)
- Low expansion foam insulation
- Flashing materials
- Weather resistive barrier
- Standard hex key set

Frame Assembly

Using a smartphone or similar device, scan the QR code or click [here](#) to play a video of this procedure.



NOTE: If the door is over 23 1/2 feet, [refer to Sill Splicing on page 7](#) prior to frame assembly.

1. For a floor channel sill, the sill track must be installed into the floor prior to frame assembly. The floor channel sill length matches the frame OM width and should be centered within the rough opening. Fasten with 1 1/2" length concrete fastener or panhead screws (depending on substrate) every 24" (610). See [Figure 1](#) and [Figure 2](#).

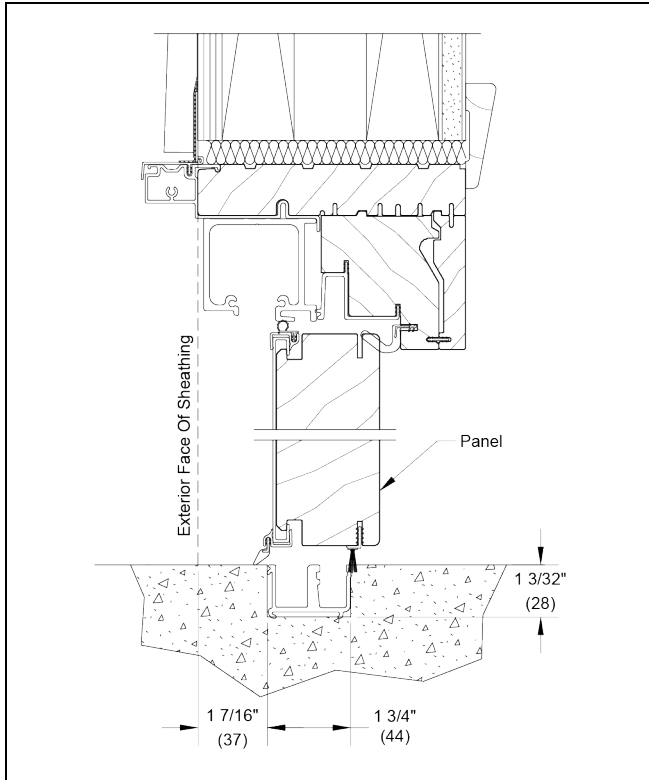

Figure 1



Figure 2 Floor channel installation (concrete shown)

1	Floor channel sill
2	1 1/2" length fastener
3	24"
4	1 7/16"

2. Fasten the sill to the jamb. Ensure the screw is in the frame cladding screw boss.

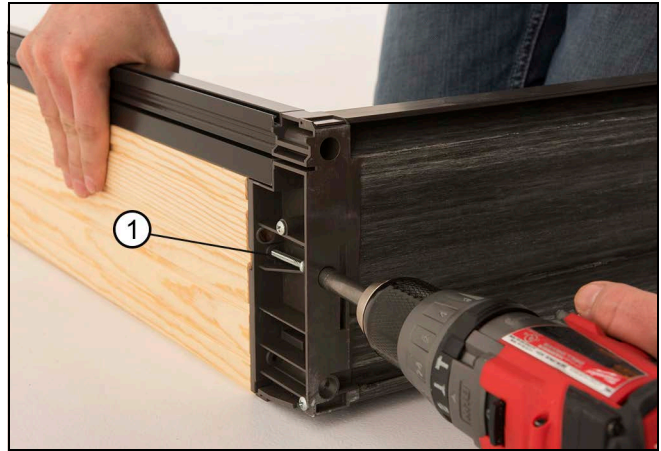

Figure 3

1	3 per side-#8x 1 3/4" pan head
---	--------------------------------

3. Install the head jamb corner keys and assemble the corners. Ensure the metal leg on the jamb goes between the aluminum head track and shoot bolt channel. See Figure 4 and Figure 5.

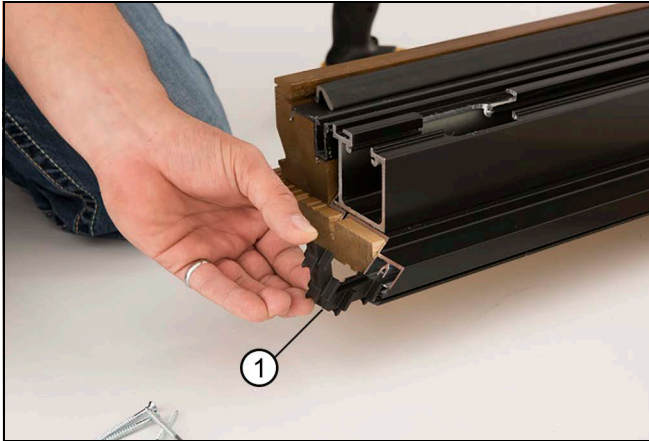

Figure 4

1	Head jamb corner key
---	----------------------

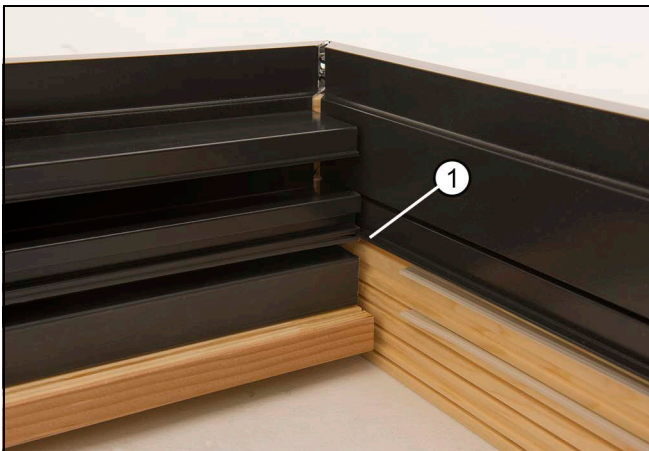

Figure 5

1	Metal leg
---	-----------

4. Fasten the jamb to the head jamb. Do not over tighten clad miter joint. See Figure 6

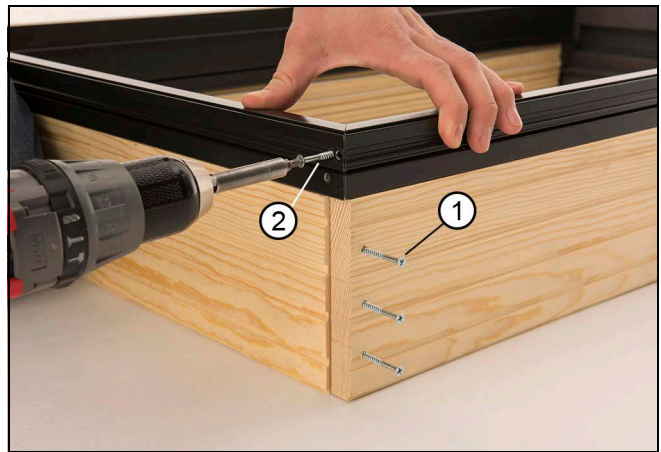

Figure 6

1	3 per side- #7 x 2" Flat head
2	1 per side- #8 x 1 1/2" Flat head

5. Inject the cladding in both holes until squeeze out occurs. See Figure 7 and Figure 8.



Figure 7

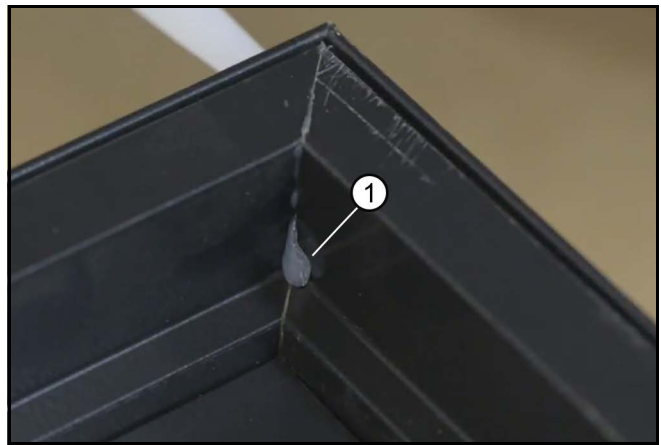

Figure 8

1	Squeeze out
---	-------------

6. For performance sills only, cut the tip on the silicone tube at the line and inject the sill corner keys until squeeze out occurs in both locations. See Figure 9 and Figure 10.



Figure 9

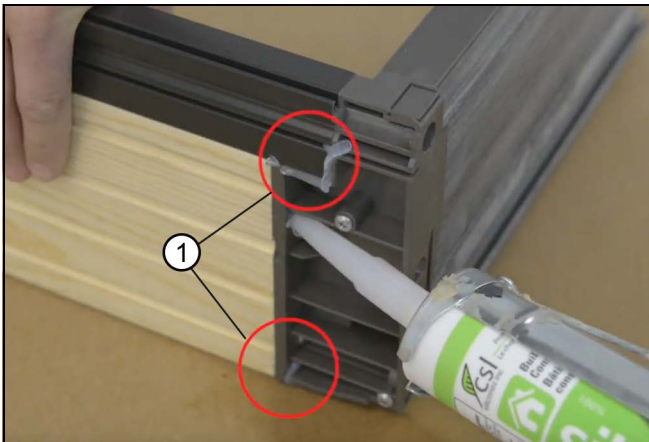

Figure 10

1	Squeeze out
---	-------------

7. Inject the cladding screw boss until squeeze out occurs. If supplied, install jamb extension. See Figure 11.

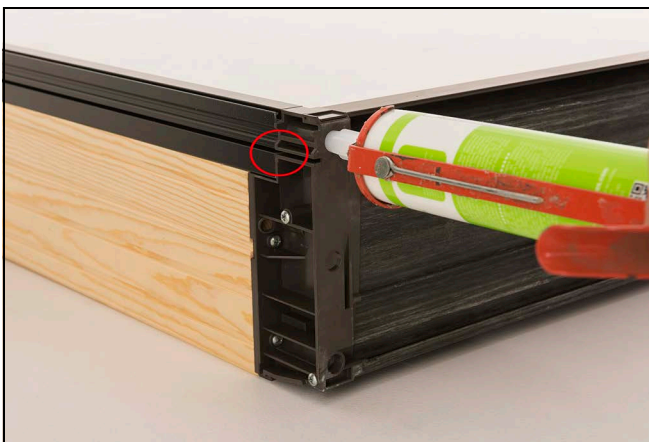

Figure 11

8. For low profile sill, inject the sill corner keys until squeeze out occurs in both directions. See Figure 12 and Figure 13.

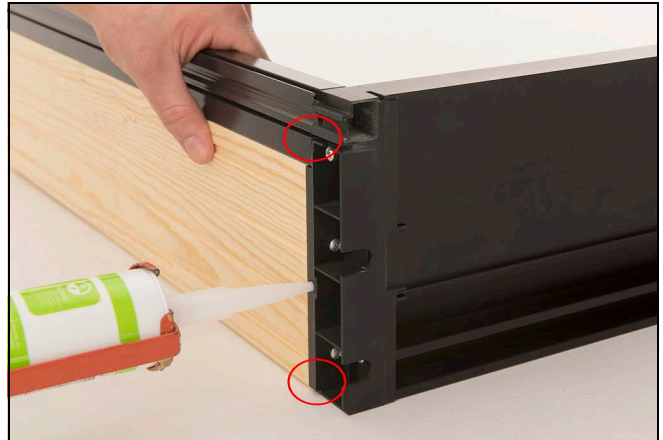

Figure 12

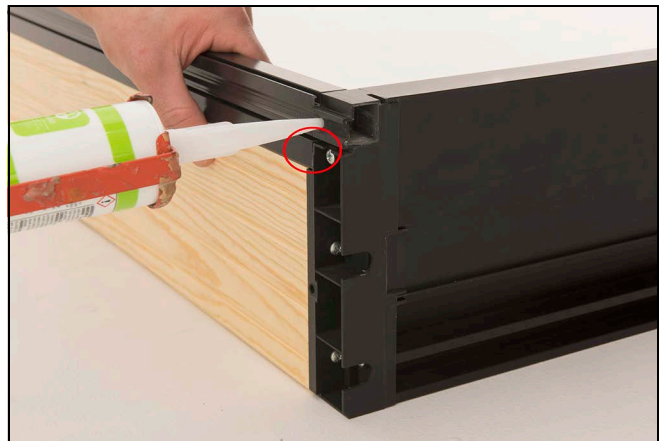

Figure 13

Splicing Sills and Head Jambs

Sill Splicing

Using a smartphone or similar device, scan the QR code or click [here](#) to play a video of this procedure.



1. Lay out the sill sections in the correct order.
2. Fasten the sill splice bracket(s) into one side of the sill. See Figure 14.

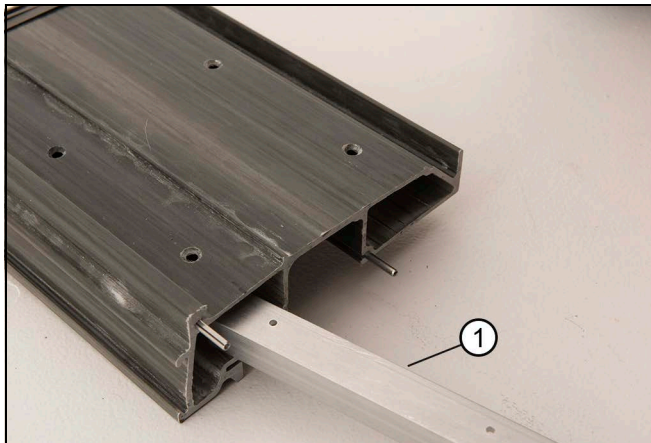

Figure 14

1	Sill splice bracket
---	---------------------

3. Apply sealant along the highlighted section. See Figure 15.

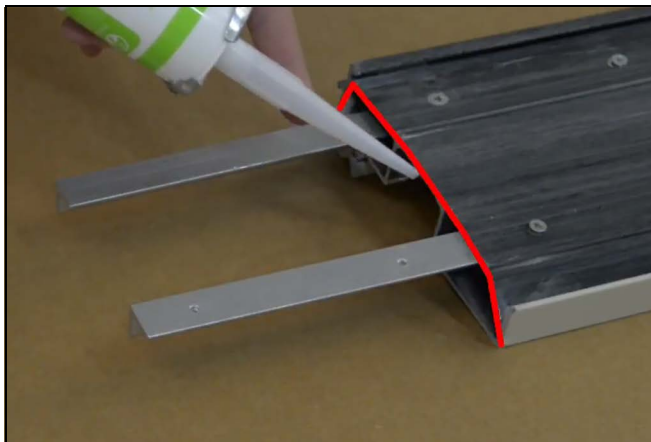

Figure 15

4. Align the sill sections and slide the parts together. See Figure 16.

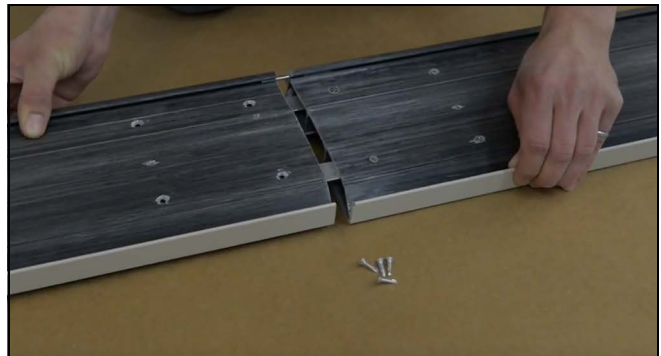

Figure 16

5. Fasten the spliced sill using self drilling screws. See Figure 17.

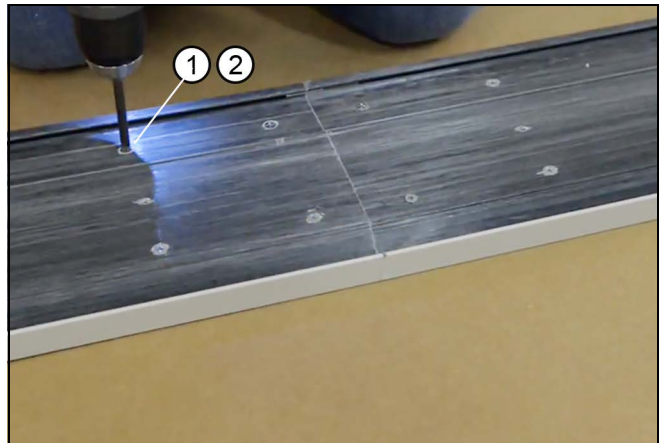

Figure 17 Performance sill shown

1	#8 x 5/8" Phillips head self drilling screws for performance sill
2	#8 x 3/4" Phillips head self drilling screws for low profile sill

6. Apply sealant over all the screws and remove excess sealant from the sill. See Figure 18.

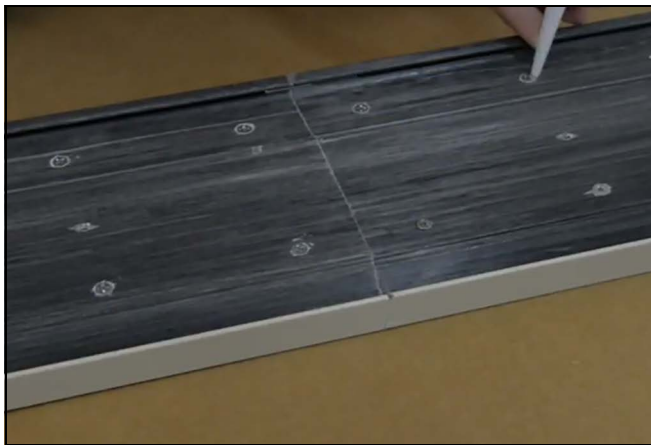

Figure 18

7. Insert weather strip 11/16" (17) from the corner key on each side. See Figure 19.

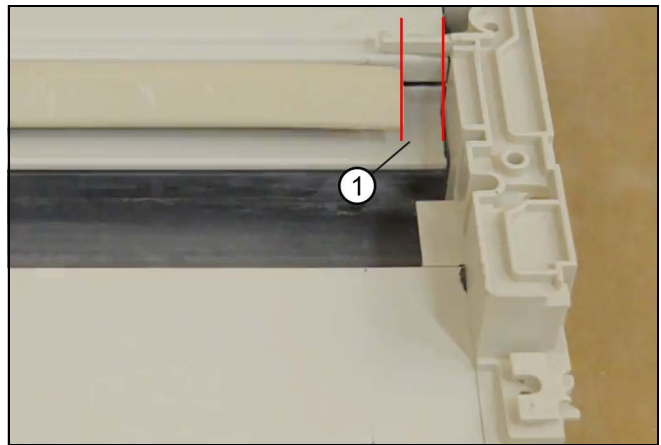

Figure 19

1	11/16" (17)
---	-------------

Splicing Head Jamb

Using a smartphone or similar device, scan the QR code below or click [here](#) to play a video of this procedure.



1. Lay out head jamb sections in correct order.
2. Remove the loose shoot bolt channel, and set aside for installation later. See Figure 20.

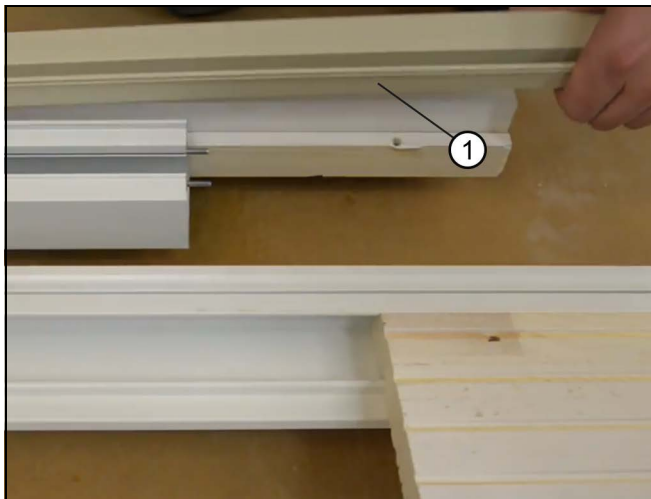

Figure 20

1	Shoot bolt channel
---	--------------------

3. Loosely fasten the frame cladding splice key to one side of the cladding. See Figure 21.

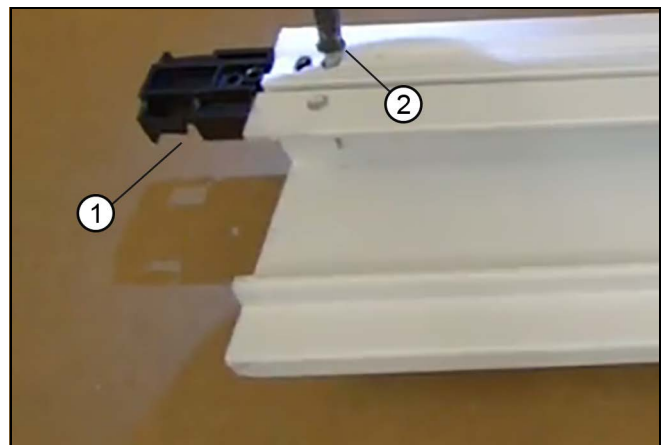

Figure 21

1	Corner key
2	#8 x 5/8" flat head

4. Align the frame cladding with the wood jamb and slide the parts together.
5. With a wood block and hammer, tap the head track to insert the alignment pins. Ensure all joints are tight. See Figure 22.

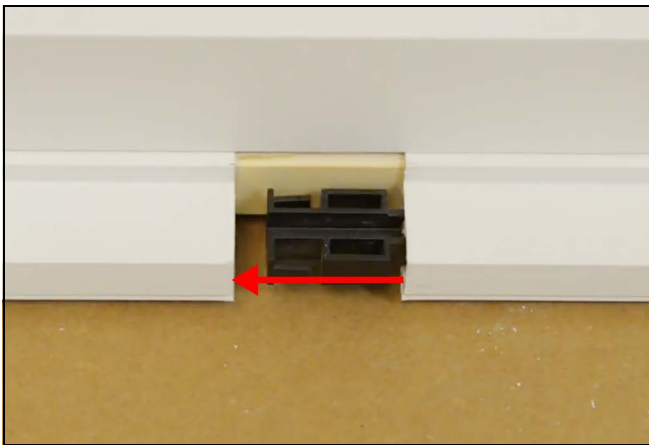

Figure 22

6. Fasten the support block to the head jamb. See Figure 23. Pre-drill the head jamb track installation holes with a 1/4" bit using the holes in the head track as a guide.

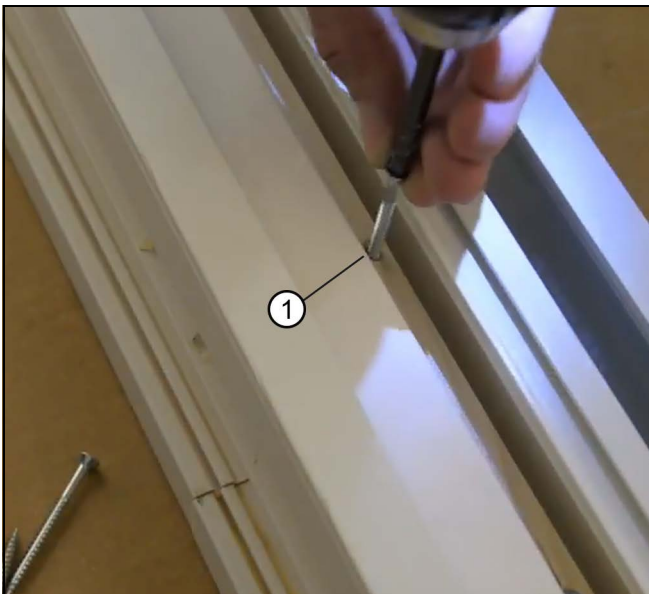

Figure 23

1	#7 x 2" flat head screw
---	-------------------------

7. Install the shoot bolt channel. See Figure 24.



Figure 24

8. Flip the head jamb over. Fasten the frame cladding splicing key. See Figure 25.

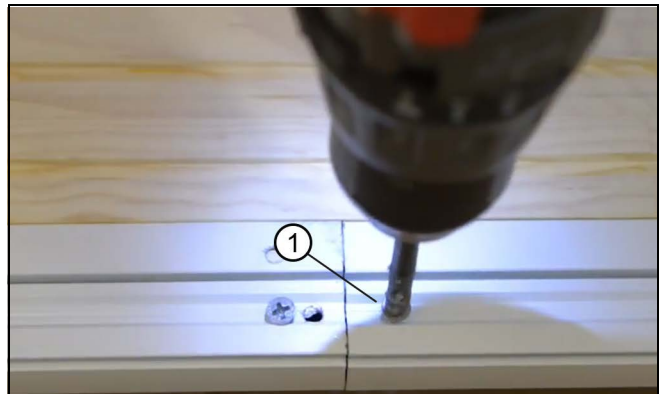

Figure 25

1	#8 x 5/8" Flat head
---	---------------------

9. Pre-drill the head jamb with a 1/8" bit using the hole in the frame cladding as a guide. **Do not drill through the face of the frame cladding.** See Figure 26.

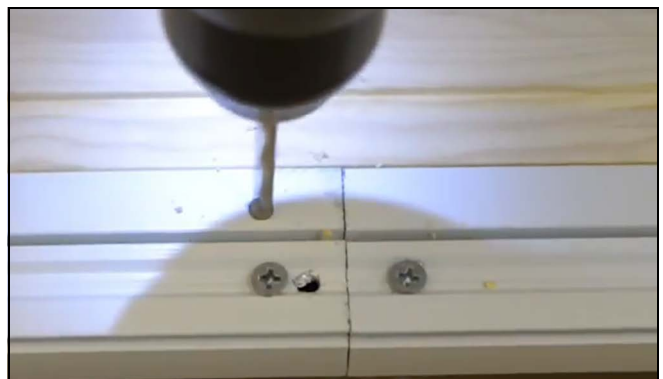

Figure 26

10. Inject both holes until squeeze out occurs on opposite sides. See Figure 27.

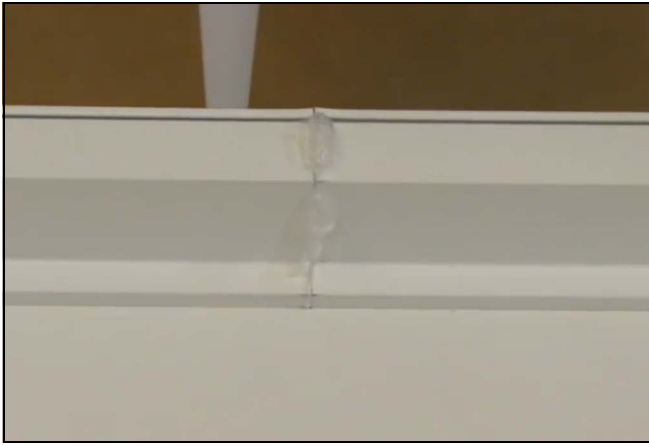

Figure 27

11. Insert the weatherstrip 11/16" (17) from the end of the support block. See Figure 28.

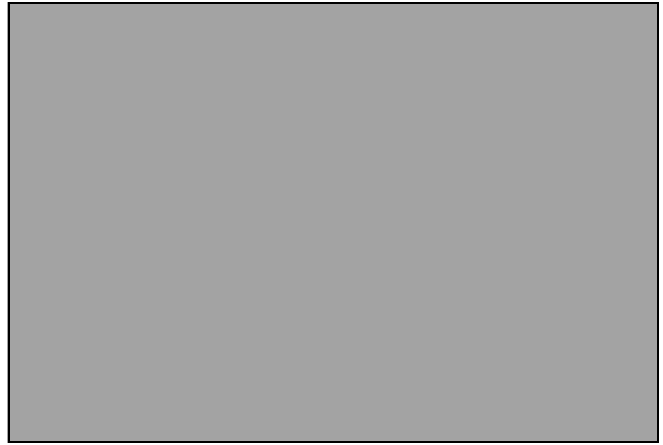

Figure 28

1	11/16" (17)
2	Weatherstrip

Frame Installation

Using a smartphone or similar device, scan the QR code below or click [here](#) to play a video of this procedure.



NOTE: Before installation, ensure the Rough Opening has been prepped according to the [site prep guide](#).

1. Frame Tolerance: the sill must be within +/- 1/16" (2) flat. The head jamb must be flat or within +1/16" of flat (not bowed down). When installed, the frame must be within +/- 3/16" (5) of square. See Figure 29.

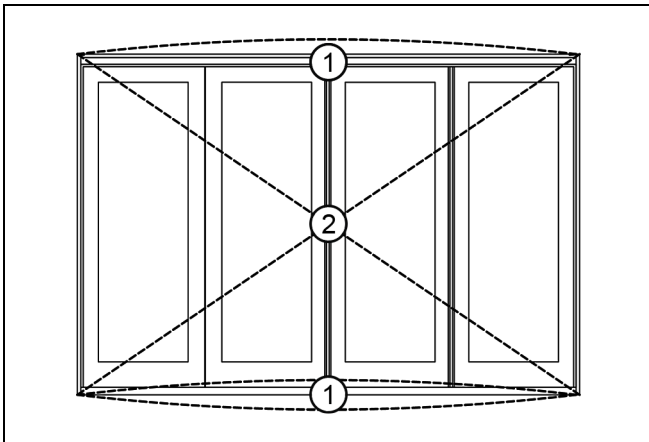

Figure 29 Frame tolerance

1	Head and sill within 1/16"
2	Square frame within 3/16"

2. Sill screws must be sealed prior to installing. Fasten sill through all pre-drilled holes. Use #8x 1 1/2" screws minimum. See Figure 30.



Figure 30

1	#8 x 1 1/2" screws minimum supplied by others.
---	--

3. Fasten jambs through all pre-drilled holes, shims should be placed at all fastening locations. See Figure 31.



Figure 31

1	#8 x 3" Flat head screws
---	--------------------------

4. Fasten the head jamb track through all the pre-drilled holes with installation screws provided. Apply sealant to the threads and heads prior to assembly. See Figure 32 and Figure 33

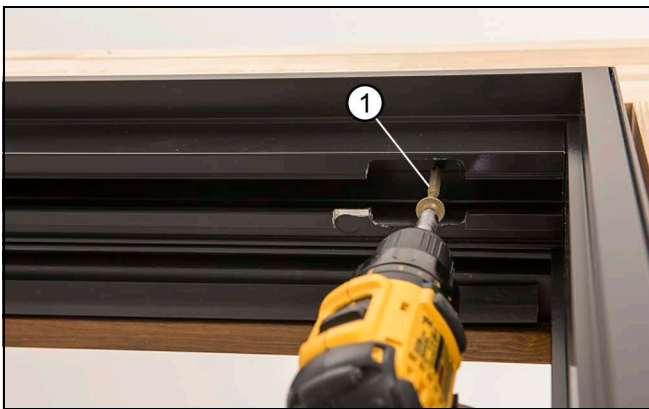

Figure 32

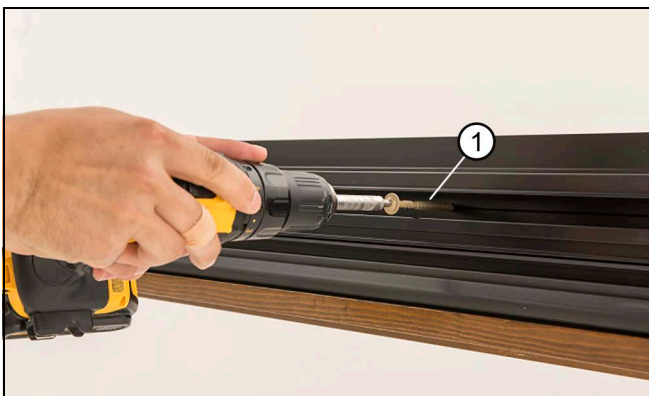

Figure 33

1	5/16" x 5" Washer head screw
---	------------------------------

5. Remove the shipping screws and pre-drill 1/4" at shipping hole locations, then drive installation screws through these holes. See Figure 34 and Figure 35.



Figure 34



Figure 35

6. Fasten the head jamb support block through all pre-drilled holes. See Figure 36.

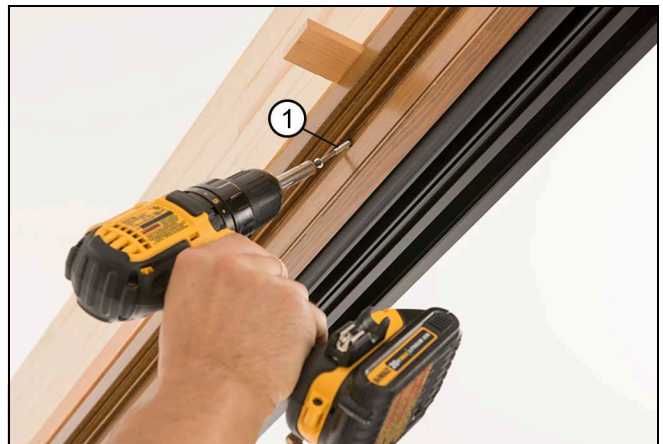

Figure 36

1	#8 x 3 1/2" flat head screw
---	-----------------------------

7. Snap in the sill insert. See [Figure 37](#), [Figure 38](#), and [Figure 39](#).



Figure 37



Figure 38



Figure 39

Hinge Installation

Using a smartphone or similar device, scan the QR code below or click [here](#) to play a video of this procedure.

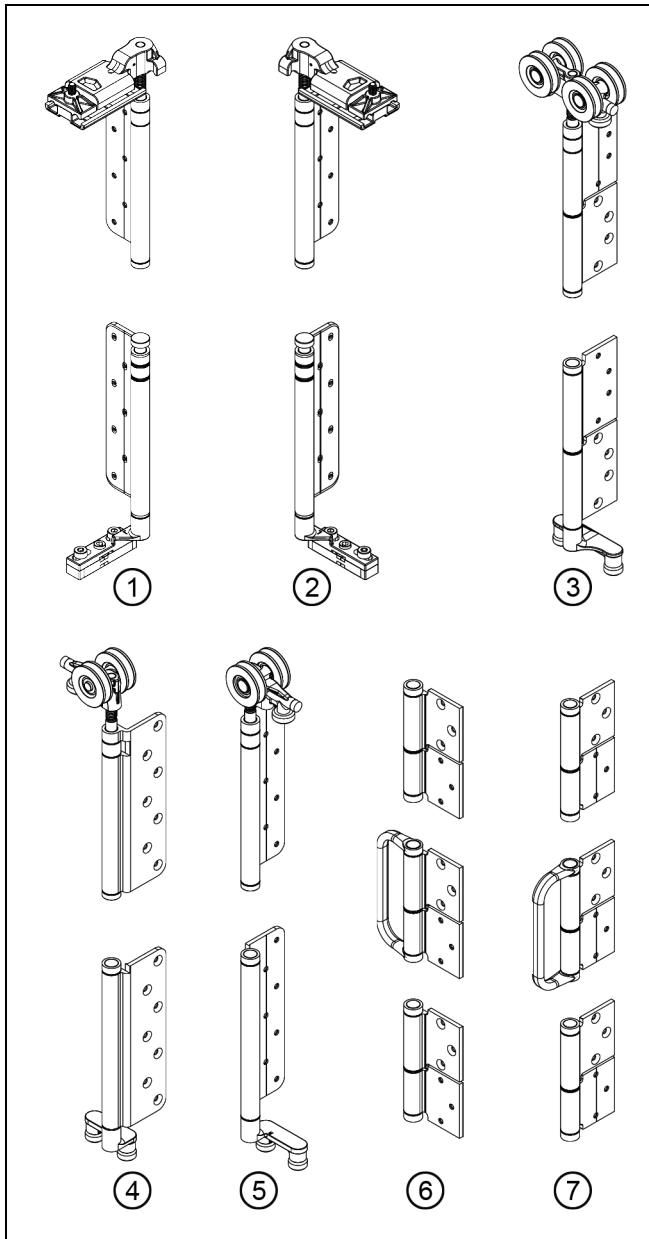

Figure 40

1	Wall Pivot Right Hand
2	Wall Pivot Left Hand
3	Intermediate Carrier
4	End Hanger Right Hand
5	End Hanger Left Hand
6	Offset Hinge
7	Straight Hinge

NOTE: For information on configuration and hinge placement, please refer to the diagram enclosed, similar to [Figure 41](#).

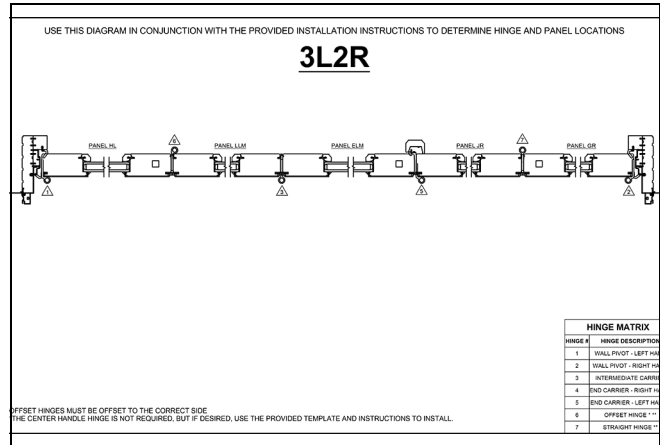

Figure 41

1. Place any top roller hinges numbered 3-5 in the head track in the correct order using the configuration diagram as a guide for your configuration. See [Figure 42](#).

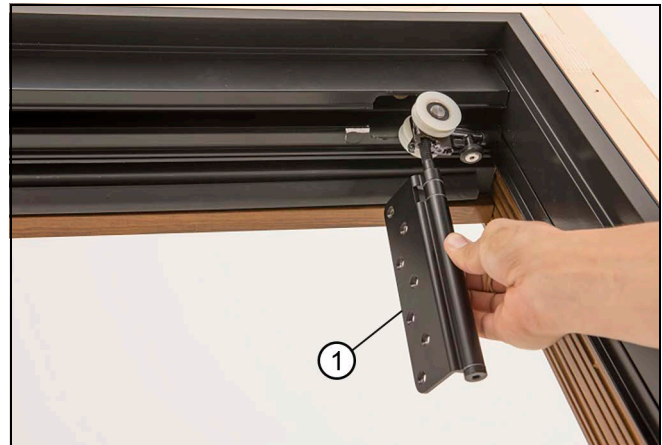

Figure 42

1	Top roller hinge
---	------------------

IMPORTANT

Ensure the small cam doesn't fall out during the [next step](#).

2. Install the top portion of any hinges 1 and 2 in the correct end of head track by loosening the two outer bolts but not removing them. See [Figure 43](#) and [Figure 44](#).



Figure 43

1	Adjustment cam
2	Outer hex bolts



Figure 46

1	Position and tighten this bolt
---	--------------------------------

4. Slightly tighten the bolt closest to the jamb.

5. Place the hinge in the middle of its adjustment range by rotating the center cam, then fully tighten the bolt closest to the jamb. See Figure 47.



Figure 44

1	Track clamp position
---	----------------------

3. Rotate the clamp and tighten the bolt furthest from the jamb. See Figure 45 and Figure 46.

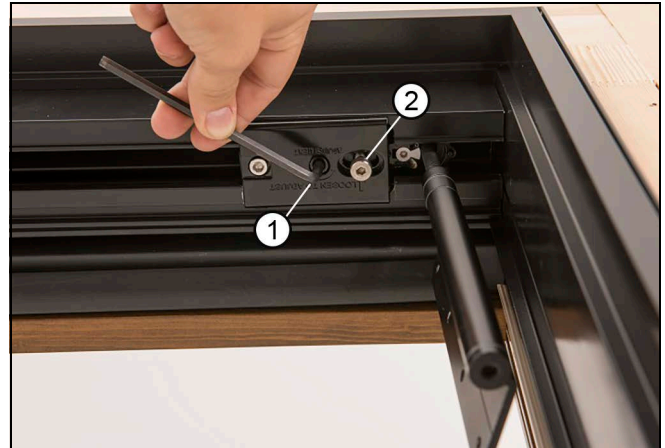

Figure 47

1	Adjustment screw
2	Tighten bolt

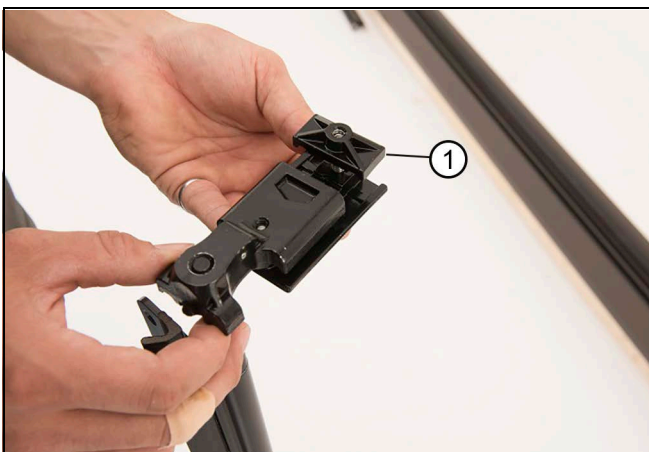

Figure 45

1	Track clamp position
---	----------------------

6. Install the bottom portion of hinges 1 and 2 in the correct end of the sill ensuring the shim is installed below it. See [Figure 48](#) and [Figure 49](#).

NOTE: On low profile and floor channel sills, the screws will stick slightly proud of the bottom of the sill.

NOTE: Hinge must be adjusted out to allow screws to go in.

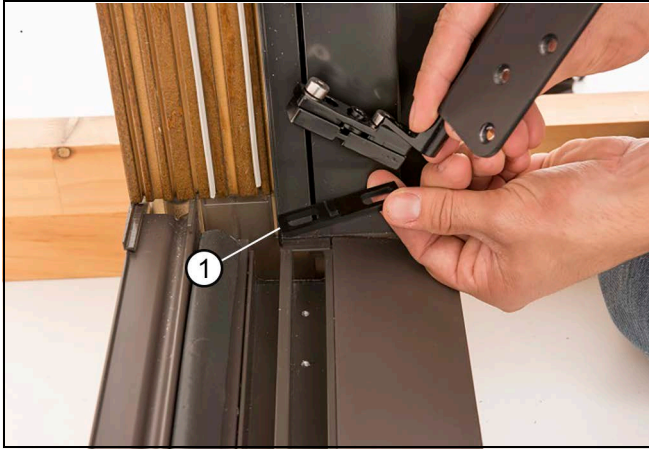

Figure 48

1	Floor shim
---	------------

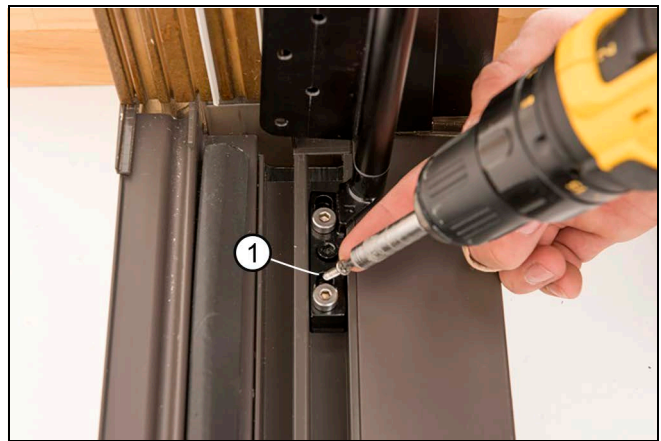

Figure 49

1	#7x3/4" Flat head
---	-------------------

7. Place the hinge in the middle of its adjustment range by rotating the center cam, then fully tighten the bolts. See [Figure 50](#).

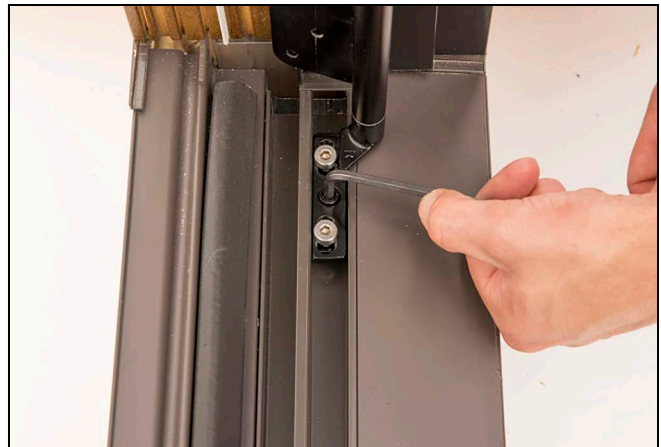

Figure 50

Hanger and Wall Pivot Adjustments

1. Side to side adjustments can only be done on the wall pivot. **Top Wall Pivot:** Loosen the hex bolt nearest to the jamb with a 5/32" hex wrench. See [Figure 51](#).



Figure 51

2. Turn the center adjustment cam with a 3/16" hex wrench to adjust the panel side to side. Tighten the bolt that was loosened. [See Figure 52.](#)



Figure 52

3. **Bottom Wall Pivot:** Loosen both 5/32" hex bolts slightly. [See Figure 53.](#)

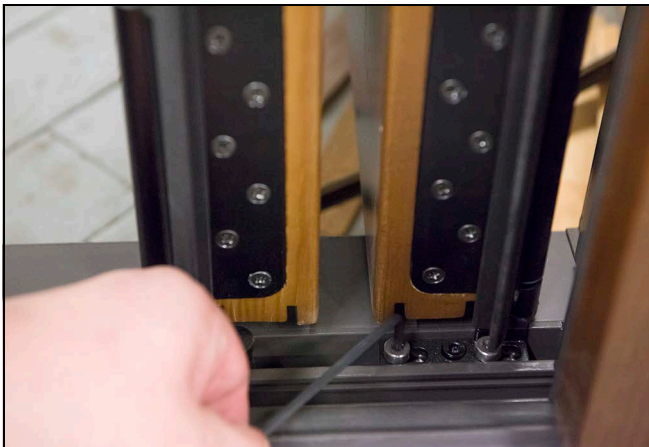

Figure 53

4. Turn the center adjustment cam with a 3/16" hex wrench to adjust side to side. Tighten the hex bolts that were loosened earlier. [See Figure 54](#)

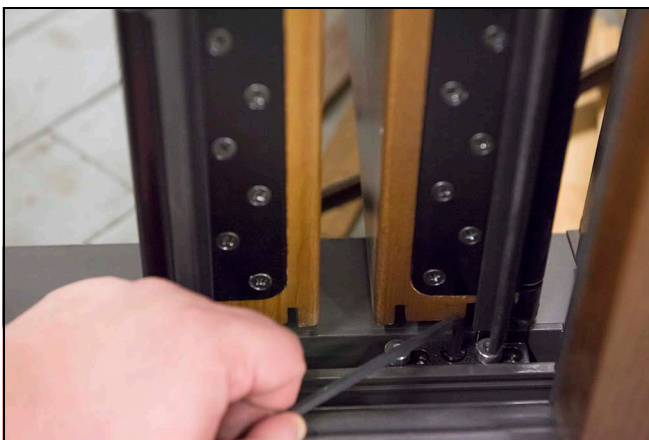

Figure 54

5. Up and down adjustment can only be done on the top hangers. Turn and hold the height adjustment lock at the base of the hinge with a 1/8" hex wrench. Use a 3/16" hex wrench in the end of the hinge to adjust the height. Turning clockwise will raise the panel while turning counter clockwise will lower the panel. [See Figure 55.](#)

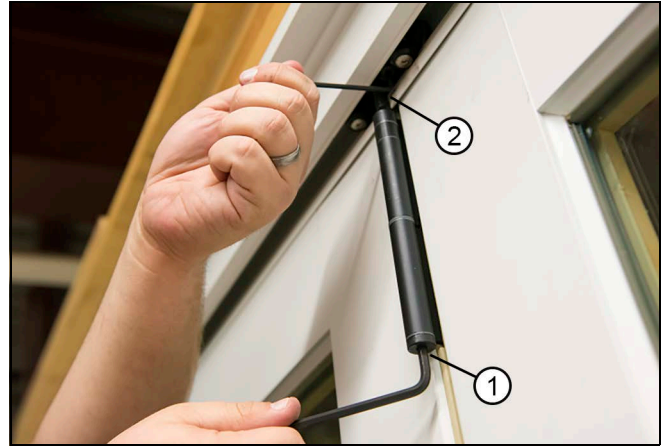

Figure 55

1	3/16" hex wrench
2	1/8" hex wrench

Panel Installation

Using a smartphone or similar device, scan the QR code below or click [here](#) to play a video of this procedure.



1. Panels are lettered according to configuration. Refer to the diagram enclosed similar to [Figure 56](#).

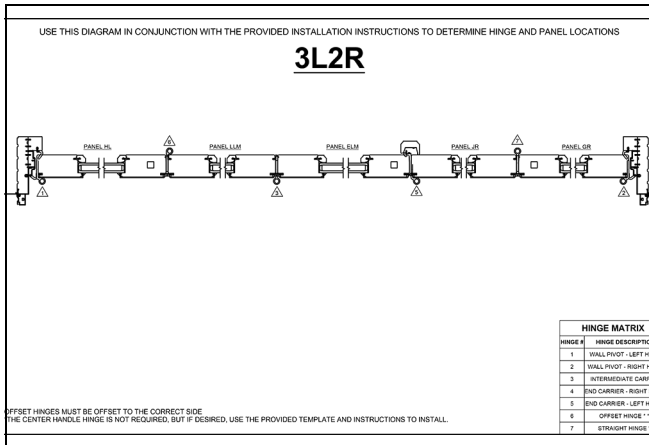

Figure 56

2. Locate any panels with the letter "M" on the end. Example (ELM). Install the magnetic catch base to the top and bottom panels prior to installing the panels. Position the magnet pads into the aluminum covers. Then fasten each to the base. [See Figure 57](#) and [Figure 58](#).

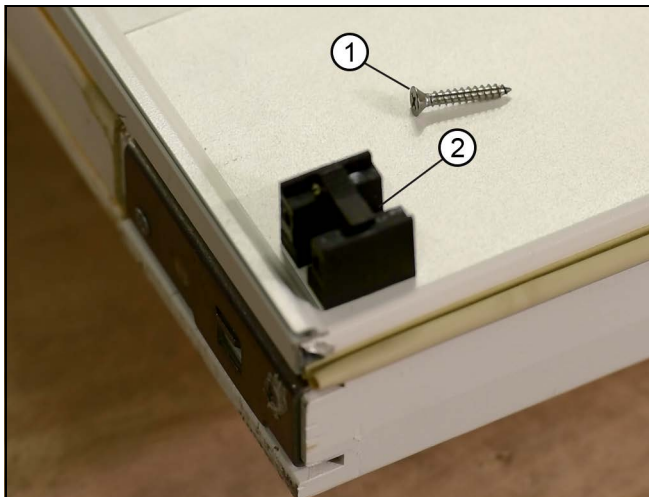

Figure 57

1	#8 x 1" Flat head screws
2	Magnetic catch base

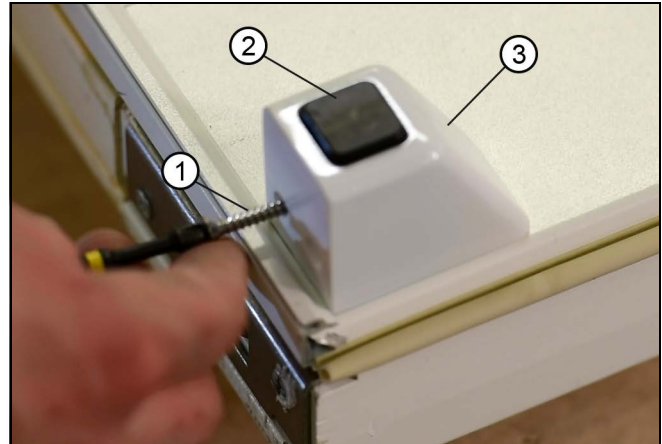

Figure 58

1	#8 x 1" Flat head screws
2	Magnet pad
3	Aluminum Cover

3. Locate the panels adjacent to any hinges numbered 1 and 2 then fasten. [See Figure 59](#) and [Figure 60](#).

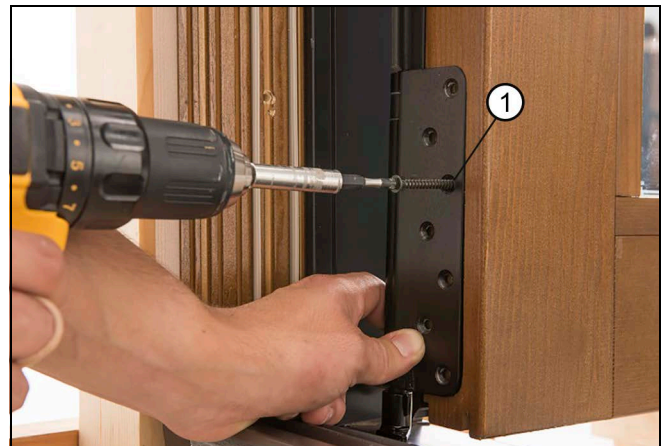

Figure 59

1	#10 x 2" flat head screw
---	--------------------------

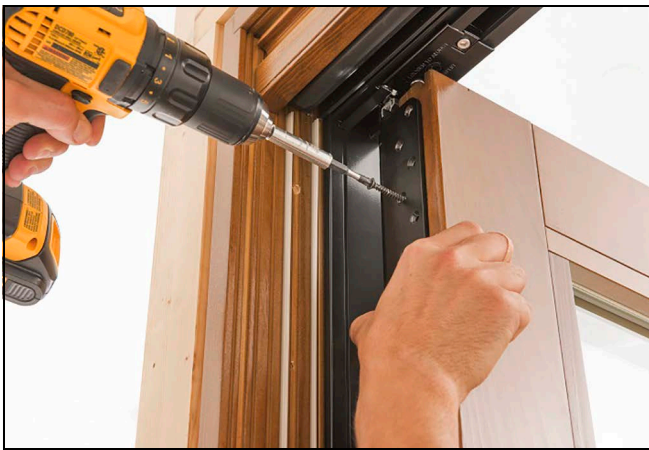

Figure 60

4. Depending on the configuration, install the next panel(s) using the configuration diagram as a guide. For interior hinges 6 or 7, use two shorter screws on hinge leaf attached to the panel with the locking handle. See [Figure 61](#).



Figure 61

1	#10 x 1 1/4" Flat head
2	#10 x 2" Flat head

5. Attach the intermediate and end hangers (hinges 3, r, and 5) if applicable to your configuration. See [Figure 62](#) and [Figure 63](#).



Figure 62

1	#10 x 2" Flat head
---	--------------------

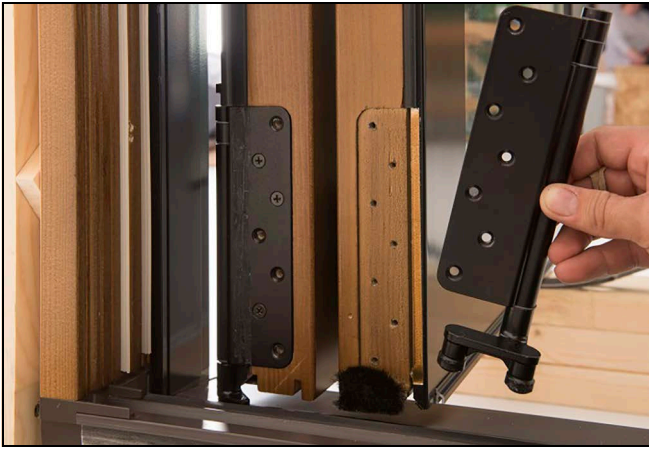

Figure 63

Hinge/Handle Optional Installation

1. Open the panel to 90 degrees. Pre-drill the holes with the template provided with the handle kit. See [Figure 64](#).



Figure 64

2. Line up the handle with the pre-drilled holes. Attach the handle with the screws provided. See [Figure 65](#).

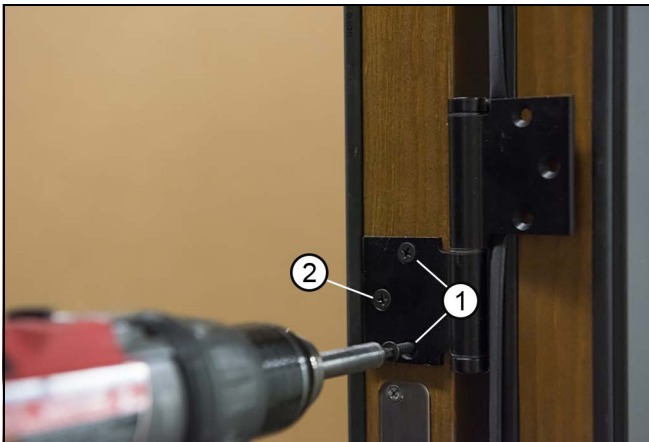

Figure 65

1	#10 x 1 1/4"
2	#10 x 2"

3. Open the hinge across to the second panel and pre-drill through the hinge. Ensure the panel gap is set using the provided template before drilling. Attach the handle with the screws provided. See [Figure 66](#).



Figure 66

4. Slice the flexible portion of the weather strip above and below the installed handle. See [Figure 67](#) and [Figure 68](#).

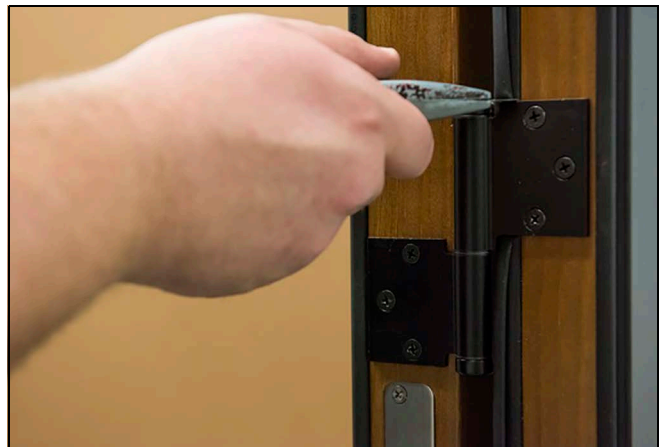

Figure 67

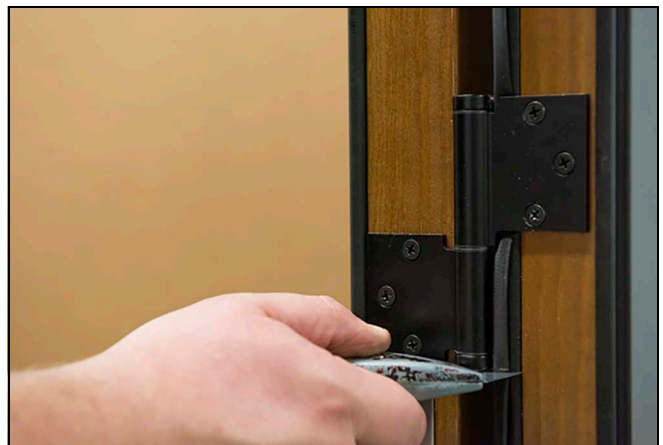

Figure 68

Final Component Installation

Using a smartphone or similar device, scan the QR code below or click [here](#) to play a video of this procedure.



1. Measure the gap between the panel and jamb. Choose the proper height support block. See [Figure 69](#) and [Figure 70](#).

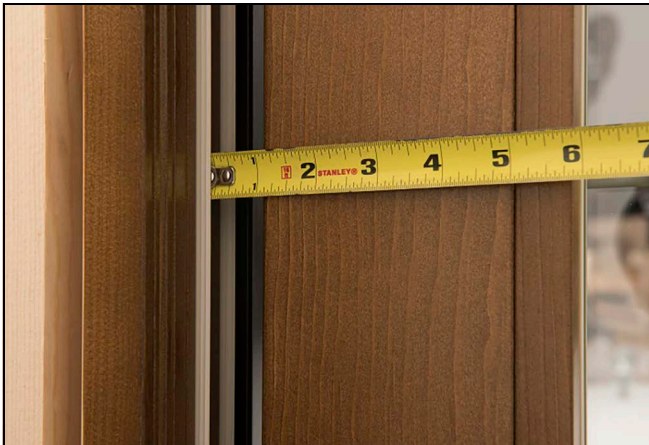

Figure 69

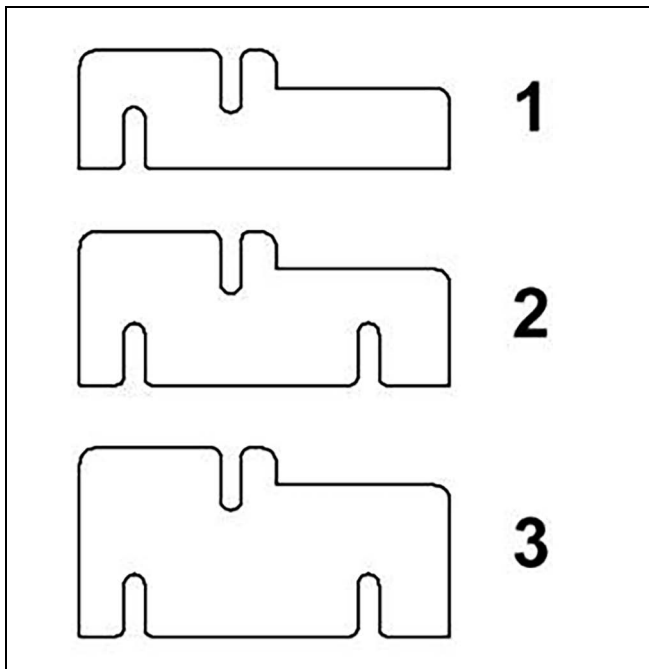

Figure 70

1	<3/4"
2	3/4" - 7/8"
3	>7/8"

2. Install the support blocks. See [Figure 71](#).

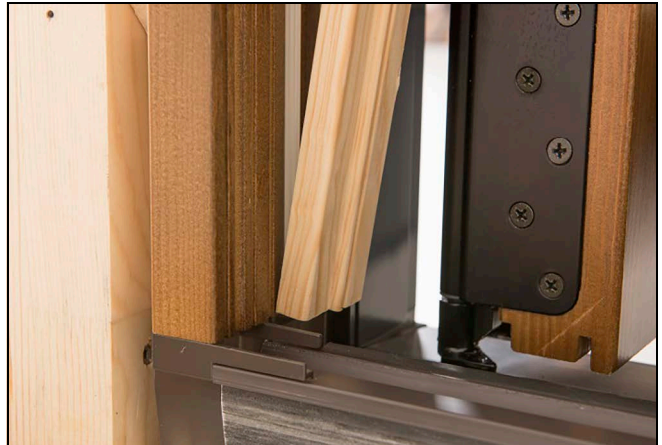

Figure 71

3. Pull the weatherstrip back approximately 12" at the sill and head jamb. See [Figure 72](#) and [Figure 73](#).



Figure 72

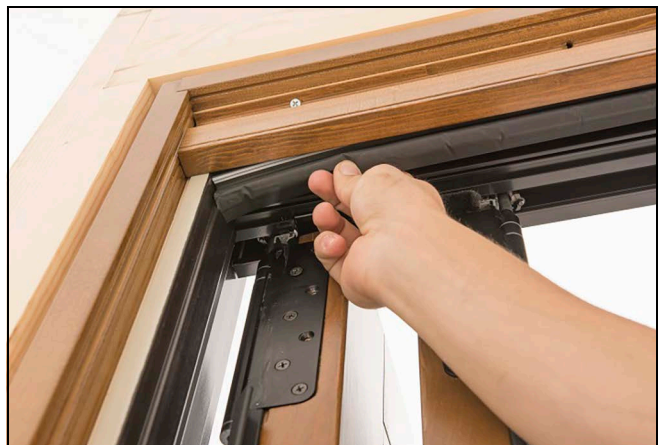

Figure 73

4. Install the frame cover. [See Figure 74.](#)

NOTE: On locking jambs, install the frame cover with the pre-punched holes for the strike.

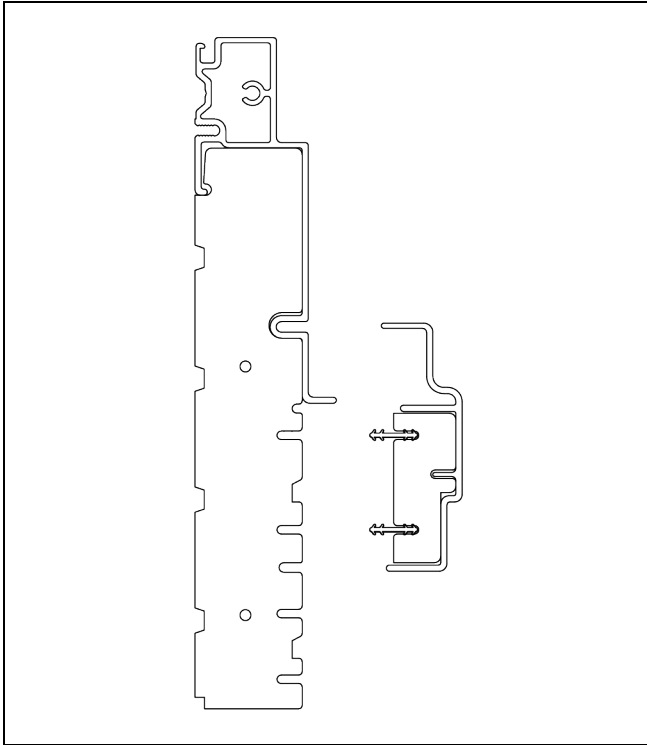

Figure 74

5. Install the head jamb part stop. [See Figure 75.](#)



Figure 75

NOTE: Install the stationary panels before installing jamb stops, refer to [Stationary Panel Installation on page 25.](#)

6. Install wood jamb part stops ensuring longer side of weather strip is toward the sill. [See Figure 76](#) and [Figure 77.](#)

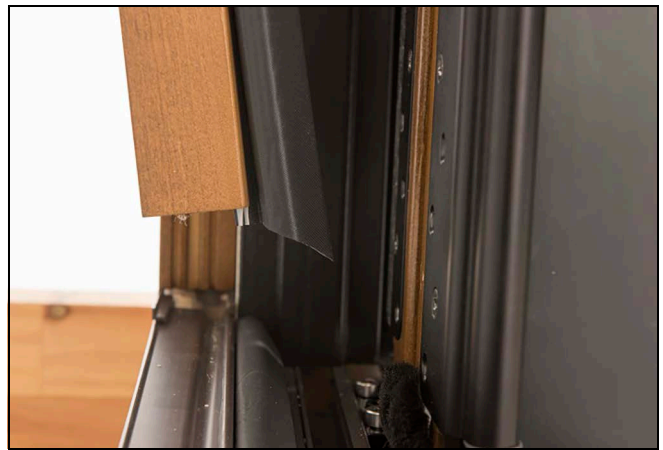

Figure 76

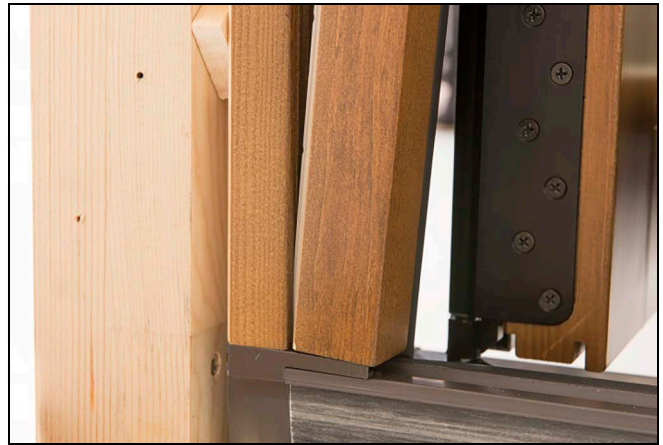

Figure 77

7. Apply the corner gasket between the sill and wood part stop. Reapply the weather strip at the side jamb and sill. [See Figure 78.](#)

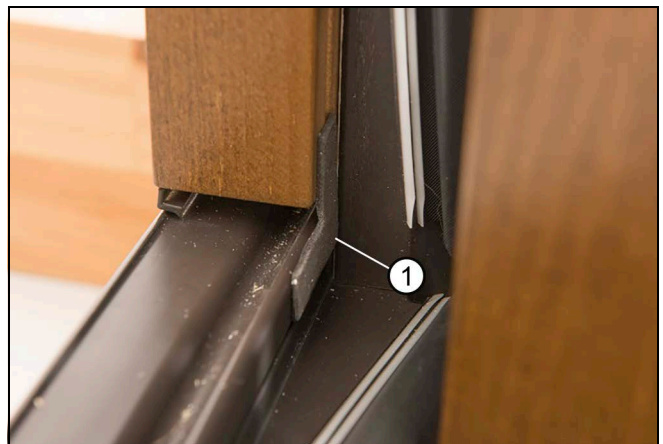

Figure 78

1	Corner gasket
---	---------------

8. Install the panel alignment bolt(s) into pre-drilled holes on jambs where wall pivot hinge sets are located. See Figure 79.



Figure 79

1	#8 x 3 1/2" Flat head BLK or BG
---	---------------------------------

9. If needed, install the strike plate using the pre-drilled holes. Ensure the support block does not interfere and there are shims behind the jamb. See Figure 80.



Figure 80

1	#8 x 3 1/2" Flat head
---	-----------------------

10. At all shoot bolt locations: open the panels slightly and measure 1 1/2" from the edge of the panel to the center of the strike location. Snap the plastic sill strikes into place and ensure the shoot bolt makes contact. See Figure 81.



Hint

If a screw is needed to hold the sill strike in place, use a #6 x 1/4" stainless steel flat head screw.



Figure 81

1	Sill strike centered at 1 1/2" from edge of panel
---	---

11. For performance sills only: peel the tape backing off the interior sill liner and rotate the liner onto the sill as shown in Figure 82 and Figure 83.



Figure 82

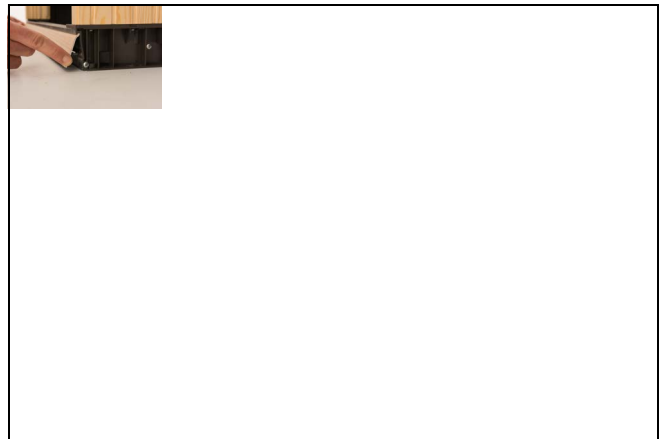

Figure 83

12. Apply the adhesive backed hinge weather strip on any hinges next to a jamb. See Figure 84.

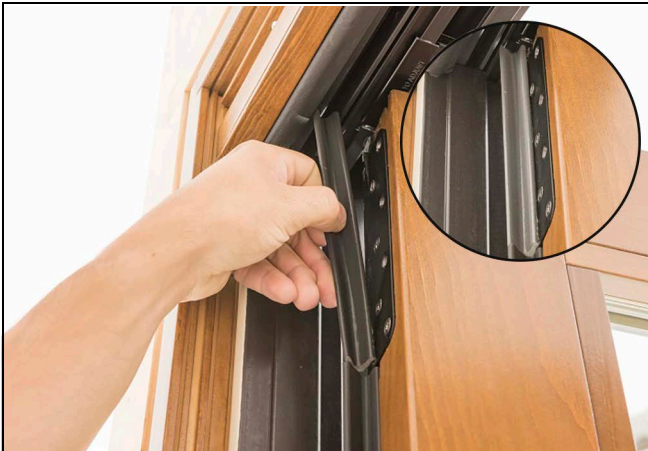

Figure 84

13. For units with a performance sill only: Apply the panel edge gasket to the top and bottom of the stile on hinge panels. See Figure 85.

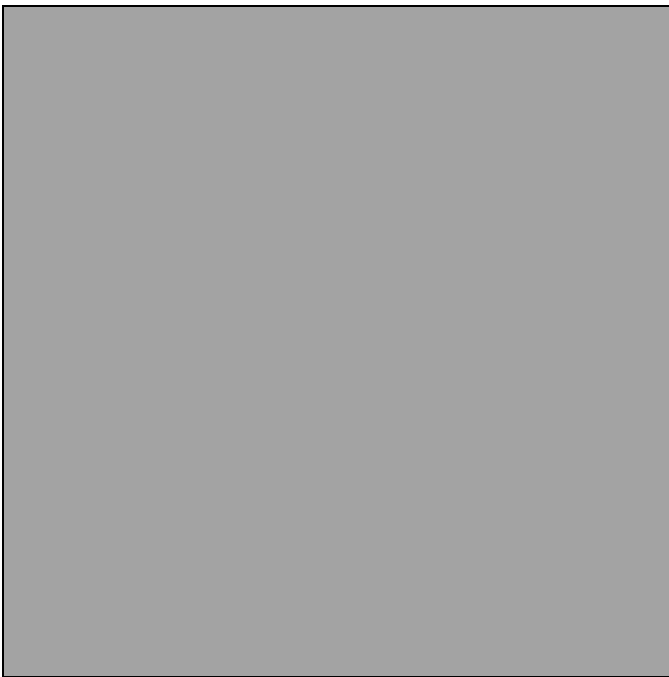

Figure 85

1	Panel edge gasket
---	-------------------

14. Install the bulb weatherstrip into the kerf on the rail cap at the bottom of the panels. This weatherstrip is taped to the panel from the factory. Make sure you orient the weatherstrip so that the bulb is angled to the exterior. See Figure 86.

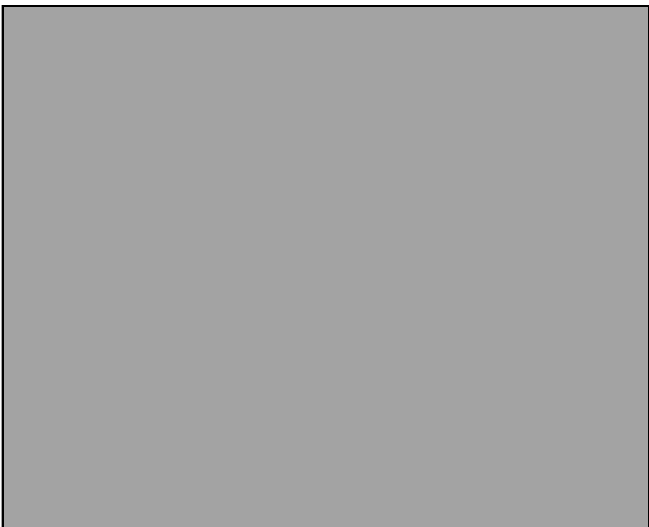

Figure 86

1	Bulb weatherstrip angled to the exterior.
---	---

NOTE: Your weatherstrip may look slightly different than the version shown in Figure 86, but should be applied in the same manner, with the bulb angled to the exterior.

Stationary Panel Installation

1. Ensure the frame covers are installed from [step 4 on page 22](#) from [Final Component Installation on page 21](#).
2. From the exterior side, tip the panel into place by placing the two sill bolts into the interior track of the sill. [See Figure 87](#).

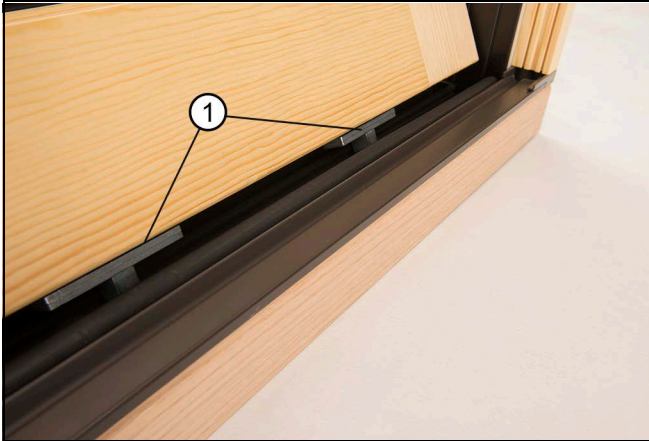

Figure 87

1	Sill bolts
---	------------

3. Flush the interior side of the jamb brackets with the interior side of the frame covers. Pre-drill with a 3/16" drill bit through the jamb only, then fasten the panel to the frame with a #8 x 3 1/2" screw. [See Figure 88](#).

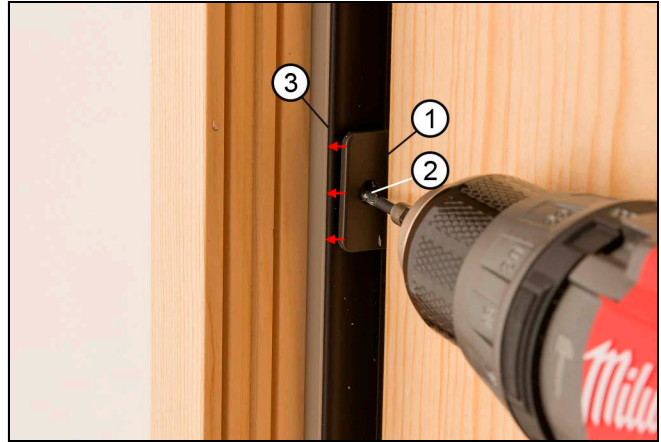

Figure 88

1	Jamb brackets
2	#8 x 3 1/2" screw
3	Frame cover edge

Technical Installation Specifications

The following details are specified for proper installation and for the unit to meet the advertised design pressure (DP) rating.

- Rough Opening Width: 1/4" - 1" (6-25) wider than window/door frame outside measurement.
- Rough Opening Height: 1/4" - 1/2" (6-13) higher than window/door frame outside measurement.
- Masonry Opening Width: 1/4 - 1/2" (6-13) wider than window/door frame outside measurement.
- Masonry Opening Height: 1/8" - 1/4" (3-6) higher than window/door frame outside measurement.
- The panning must drain water to the exterior of the cladding OR the exterior surface of a concealed weather resistive barrier.
- Do not use chemically treated products for shim material.
- Fasteners penetrating chemically treated lumber must be a minimum of 0.90 oz/ft² zinc hot dipped galvanized or stainless steel type 304 or 316.
- The window frame must not come into direct contact with chemically treated wood products.

CAUTION!

Be aware that the use of sill pans and other barriers will decrease the rough opening height clearance. Adjust opening dimensions accordingly.

- The panning system used in these instructions is one component in a structure's overall water management system. It should be used in conjunction with an appropriate drainage plane compatible with the exterior cladding.
- Flashing materials must comply with ASTM E2112-01, section 5.13 and be compatible with all materials used in installation including panning systems, air barriers and building papers, sheathing, and the window unit.
- Properly flash and/or seal all windows at the exterior, perimeter.
- Sealants used for installation must be Grade NS Class 25 per ASTM C920 and compatible with the building exterior, window exterior surface, and flashing/water management materials.
- Optional foams used for installation must be low expansion only. Foam and foam application must comply with ASTM E2112-01, SEC 5.9.2
- For units with flat casing install with installation brackets, structural masonry brackets, or jamb screws.
- Shims 4" - 6" (102-152) from each corner on jambs and head jambs. Install additional shims at 15" (381) on center and at all locking points. always shim at the check rails and meeting stiles.