

# Modern Direct Glaze

## Installation and Mulling Instructions

---

**ABSTRACT:** Please read these instructions in their entirety before beginning to install your Marvin window product. These instructions demonstrate the installation of a Marvin Modern aluminum and fiberglass window in new wood frame construction using an industry approved water management system. For installation using other construction methods such as remodeling, replacement, and recessed openings refer to ASTM E2112, "Standard Practice for Installation of Exterior Windows, Doors and Skylights." Information for ASTM E2112 can be found on the ASTM website, [www.astm.org](http://www.astm.org).

For product specific issues, service instructions, and other field service guides, refer to the Marvin Service Manual, visit our website at [www.marvin.com](http://www.marvin.com), or contact your Marvin representative.

Regional standard practices, environmental conditions, and codes may vary and supersede the procedures contained within. The responsibility for compliance is yours: the installer, inspector, and owner(s).

The procedures within these instructions are consistent with those used in testing to achieve the advertised DP rating.

The English language version of this instruction is the official version and shall take precedence over any translation.

# Table of Contents

---

Hazards and Warnings.....	3
What is Included in the Job Box.....	3
Installer and Builder Information .....	3
After Market Products .....	4
Materials Needed.....	4
Tools Recommended .....	4
Preparing the Opening.....	5
Rough and Masonry Opening Requirements.....	5
Cutting the Weather Resistive Barrier (WRB) and Pan Flashing.....	6
Install the Window.....	9
Preparing the Window.....	9
Mulling.....	14
Install Interior Covers .....	19
Installing Covers on Angled Polygons.....	20
Final Steps .....	21
Flashing the Installation .....	21
Insulating and Sealing the Installation .....	24
Technical Specifications .....	25

## Hazards and Warnings

### **WARNING!**

Do NOT lift or move without proper equipment. Read, understand, and follow all lift equipment manufacturers' instructions and safety information.

### **WARNING!**

Drilling, sawing, sanding or machining wood products can expose you to wood dust, a substance known to the State of California to cause cancer. Avoid inhaling wood dust or use a dust mask or other safeguards for personal protection. For more information go to [www.P65Warnings.ca.gov/wood](http://www.P65Warnings.ca.gov/wood).

### **WARNING!**

This product can expose you to chemicals including titanium oxide, which is known to the state of California to cause cancer. For more information, go to [www.P65Warnings.ca.gov](http://www.P65Warnings.ca.gov).

### **WARNING!**

This product can expose you to chemicals including methanol, which is known to the state of California to cause birth defects or other reproductive harm. For more information, go to [www.P65Warnings.ca.gov](http://www.P65Warnings.ca.gov).

### **WARNING!**

Always practice safety! Wear the appropriate eye, ear, and hand protection, especially when working with power tools.

### **CAUTION!**

**Wear gloves and protective clothing** when handling the frame components. Some high-density fiberglass surfaces are not coated and can leave splinters in bare skin.

## What is Included in the Job Box

Refer to the content list included in your job box for specific items that are included with your order. Sealants, hardware, fasteners, and many installation related parts are included with the window. See [Materials Needed on page 4](#) for other items you will need to successfully install your Modern Direct Glaze window.

## Installer and Builder Information

- Always provide a copy of these instructions for the current homeowner.
- Plan sizing of rough opening and clearance from exterior finishing systems to allow for normal materials shrinkage or shifting (e.g. wood structure with brick veneer; allow adequate clearance at the sill). Failure to do so can void the Marvin warranty coverage.
- Refer to the Technical Installation Specifications section for technical specifications regarding the installation of this product. These installation requirements as well as the details in the section

must be followed to achieve the advertised Performance Grade (PG) rating of this product.

- It is the responsibility of the builder, installer, and subcontractors to protect the interior and exterior of windows or doors from contact with harsh chemical washes, construction material contamination and moisture. Damage to glazing, hardware, weather strip and cladding/wood can occur. Protect with painters tape and/or protective sheathing as

required. Follow all guidelines regarding material use, preparation, personal safety and disposal.

- Contact your Marvin supplier if you have any questions regarding product and materials used in manufacturing or questions on replacement parts.
- Please refer to the PDF version of this instruction for further information regarding best practices installer and builder information, code, and other legal requirements. The PDF version is the official document of record.

## After Market Products

Alterations to Marvin products including window films, insulating or reflective interior window treatments or additional glazings can cause excessive heat buildup and/or condensation. They may lead to premature failures not covered under warranty by Marvin Windows and Doors.

Before purchasing or applying any product that may affect the installation or performance of Marvin windows or doors, contact the manufacturer of after-market product/glazings that are not supplied by Marvin and request written product use, associated warranties and damage coverage. Provide this information and warranties to the end user and/or building owner for future reference.

## Materials Needed

You will need to provide the following items to successfully install your Marvin Modern Direct Glaze window.

- Drip Cap
- Flashing materials
- Backing material (foam backer rod)
- Shims (composite recommended)
- Perimeter sealant
- Insulation and/or low expansion foam insulation

## Tools Recommended

- Tape Measure
- Speed square
- Power drill/driver
- Torx® T20 and T25 bits
- Level/laser level

# Preparing the Opening

## Rough and Masonry Opening Requirements

1. Rough opening (RO) width may be up to 1 1/2" (38) wider (3/4" on each side) than the outside measurement (OM) of the frame. The RO height may be up to 1 1/2" taller than the OM of the frame. See Figure 1.

### IMPORTANT

Rough openings are tested and certified at 3/4" on each side, the sill, and at the head jamb. Marvin Order Management System (OMS) will add 1 1/2" to the frame width **but only** 3/4" to the frame height when calculating the rough opening.

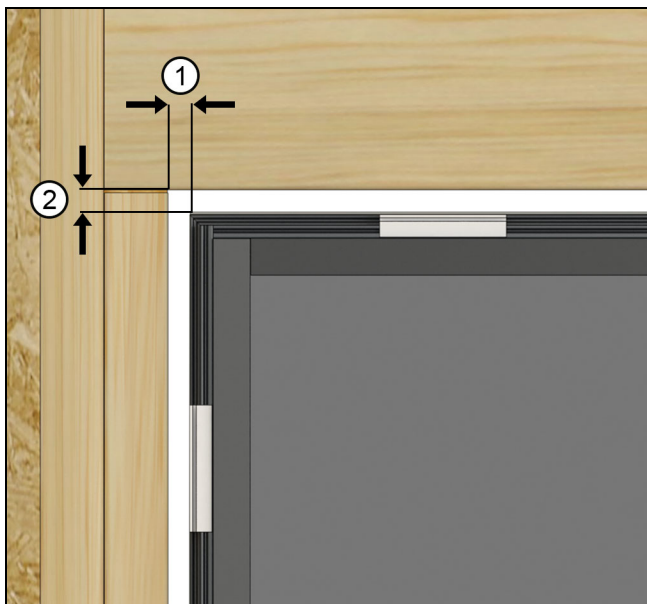

Figure 1 RO Width and Height clearance

1	RO Width (3/4" on each side)
2	RO Height (3/4" taller than OM of frame)

2. On shapes such as trapezoids, triangles, and pentagons, make sure there is proper bracing for fastening. See Figure 2.



Figure 2 Example of bracing for polygon shapes.

## Brick Bind

On standard wood frame construction with brick veneer, make sure there is at least 1/2" (13) between the bottom of the window sill (or eventual placement of the window) and the top row of brick to avoid "brick bind". See [Figure 3](#).

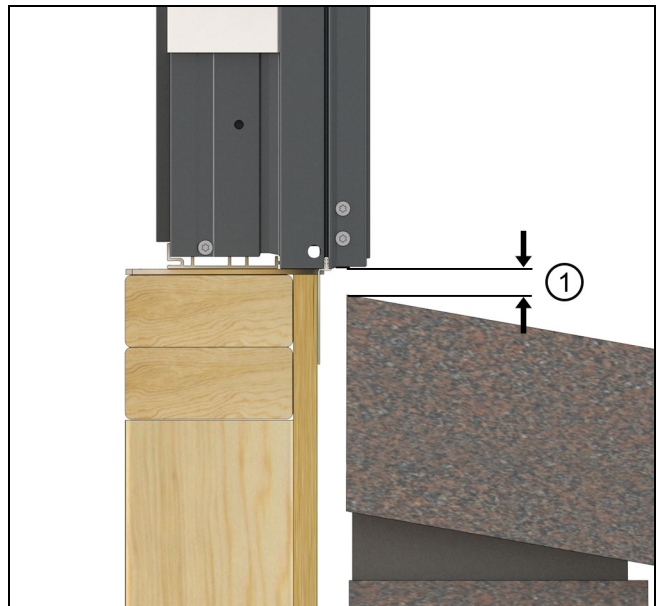

Figure 3 Avoid brick bind, maintain 1/2" gap

1	1/2" (13)
---	-----------

---

## Cutting the Weather Resistive Barrier (WRB) and Pan Flashing

*NOTE: This does not apply to self-adhering WRB sheathing systems.*

1. Make horizontal cuts to the Weather Resistive Barrier (WRB) across the top and bottom of the Rough Opening. Make a vertical cut down the center of the RO. then make 45 degree cuts away from the corners of the top of the RO. See [Figure 4](#).

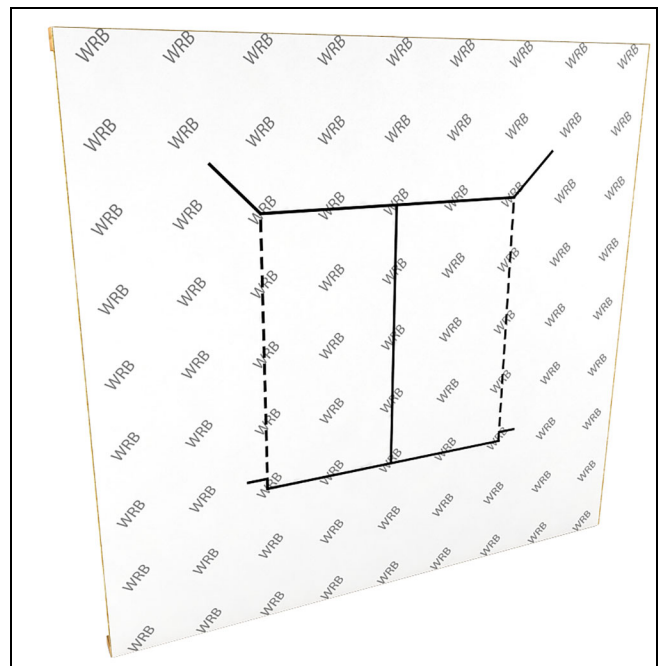

Figure 4

2. Trim up from the bottom corners about 2" (51) and then make an additional horizontal cut about 3 1/2" (89) wide. See [Figure 5](#).

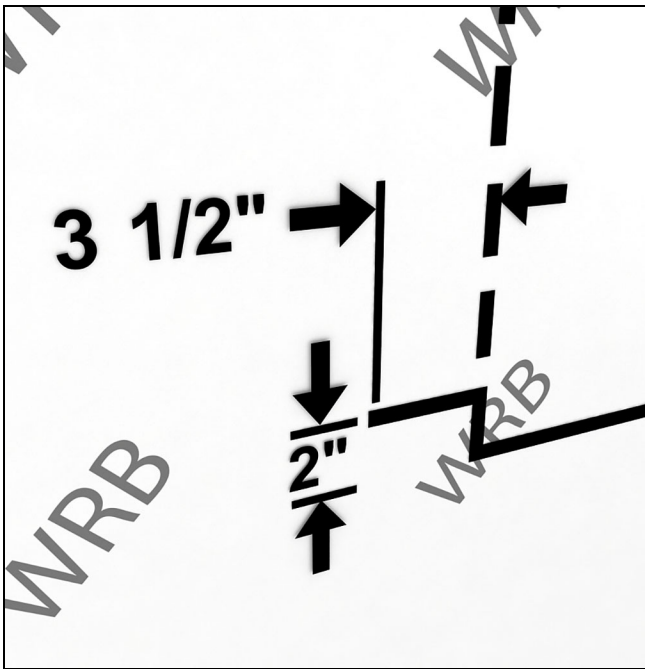

Figure 5

3. Flip the top up and side flaps away and tack temporarily. See Figure 6.



Figure 6

4. Optional: Add a continuous "Sill Wedge" out of cedar siding or similar water resistant material to create a positive drainage slope. Glue it to the RO sill with two beads of adhesive and screw in place. See Figure 7.

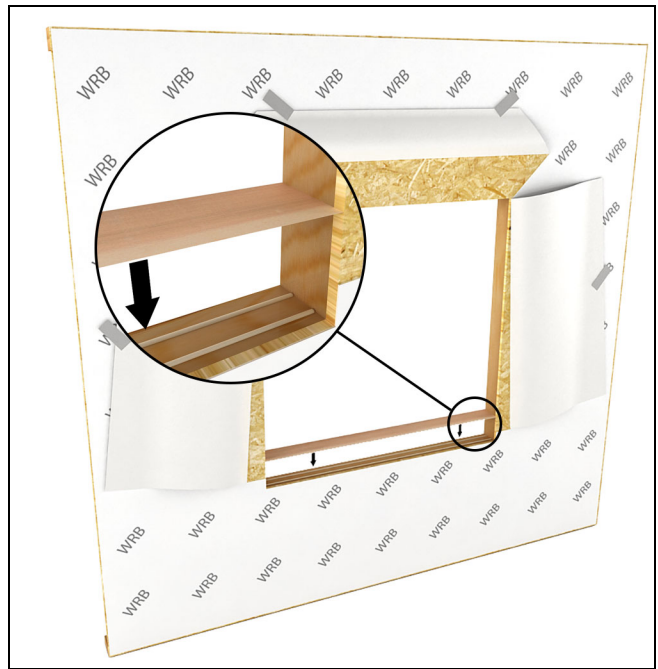

Figure 7

NOTE: This will affect your RO height, plan accordingly.

5. TYPE III Sill Pan Flash: Apply self sealing flexible membrane slope. See Figure 8.

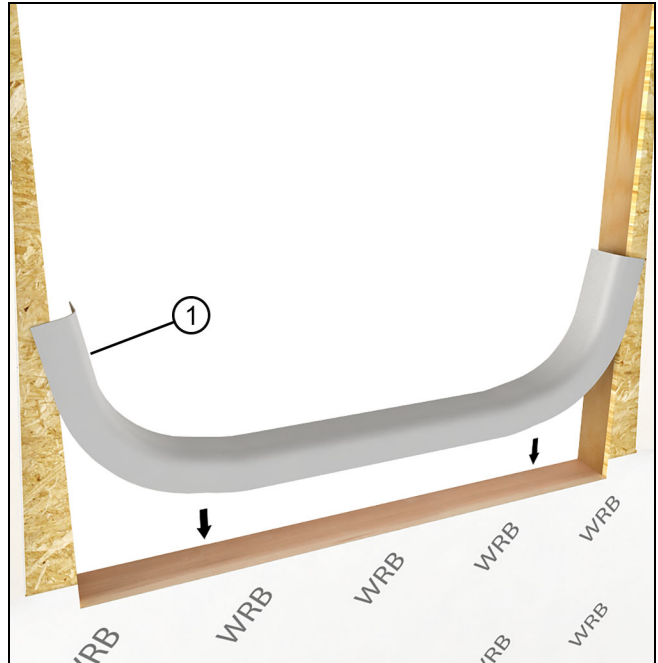

Figure 8

1	Flexible flashing membrane
---	----------------------------

NOTE: Some situations call for an upturned leg at the interior. If that is the case, do so using the excess sill flashing membrane to the interior.

6. Wrap side flaps to the interior and staple in place about 1 1/2" (38) from the interior edge of the opening. Cut the excess off near the staple so that a 1" - 1 1/2" (25-38) strip of bare wood is exposed. Tape this edge with seam seal tape. See Figure 9.

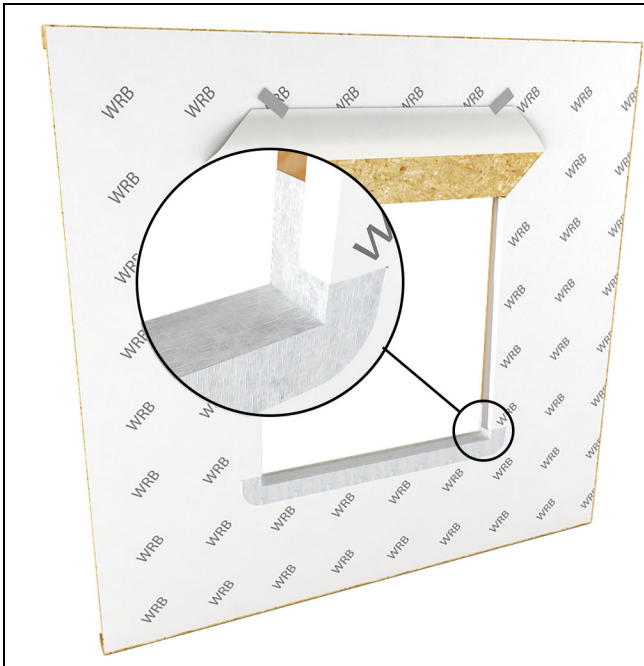

Figure 9

7. Apply seam seal tape over the corners. Place plastic or composite shims at the ends and in the middle of the RO to counter the slope of the sill wedge and support the unit. Fasten with adhesive or finish nails. If using finish nails, place adhesive under shim where the nail will penetrate. See Figure 10.

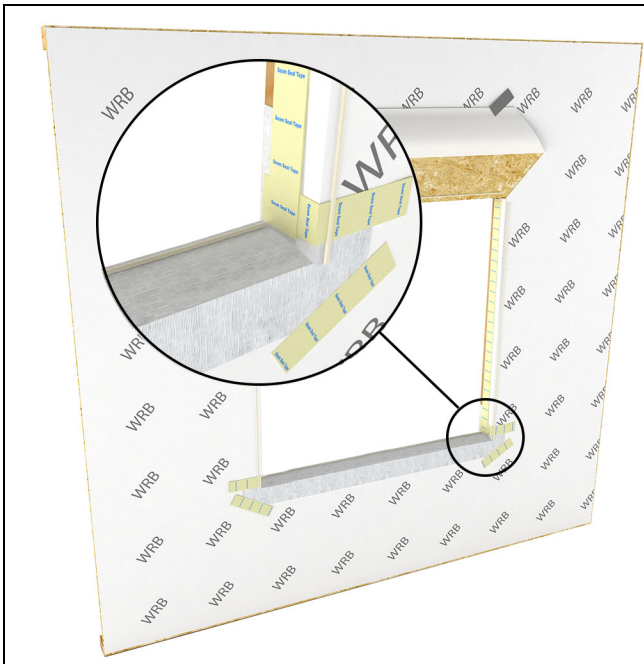

Figure 10



# Install the Window

Using a smartphone or similar device, scan the QR code below or click [here](#) to play a video of this procedure.



## **WARNING!**

Do NOT lift or move without proper equipment. Read, understand, and follow all lift equipment manufacturers' instructions and safety information.

## **Seek Assistance**

Some large windows and/or assemblies are very heavy. Avoid injury by getting help to lift and position the window into the rough opening.

### **Preparing the Window**

1. Remove any packaging and dispose of properly.
2. On factory mullered units, remove and discard the small piece of mull pin and screws. This is used for shipping purposes only.



Figure 11

1	Mull support (mull pin material)
---	----------------------------------

**NOTE:** Nail fin is used for positioning only. It is not required that you fasten the nail fin to the wall. Through jamb installation is required using fasteners provided. Shim blocks are installed at every installation hole to provide a flat spot for shimming. **Do not remove the shim blocks.**



Figure 12

1	Shim block
---	------------

## Level and Plumb

1. Center the window in the opening. Level at the sill and plumb the frame (interior/exterior). Shim under the jambs to bring to level if necessary. See Figure 14 and Figure 15.

*NOTE: Rough opening (RO) width may be up to 1 1/2" (38) wider (3/4" on each side) than the outside measurement (OM) of the frame. The RO height may be up to 1 1/2" taller than the OM of the frame. See Figure 1.*

### IMPORTANT

Rough openings are tested and certified at 3/4" on each side, the sill, and at the head jamb. Marvin Order Management System (OMS) will add 1 1/2" to the frame width **but only** 3/4" to the frame height when calculating the rough opening.

### IMPORTANT

When using drywall return (or equivalent) at the sill greater than 1/2" thickness, you will need to shim beneath the sill to avoid interference with interior covers.

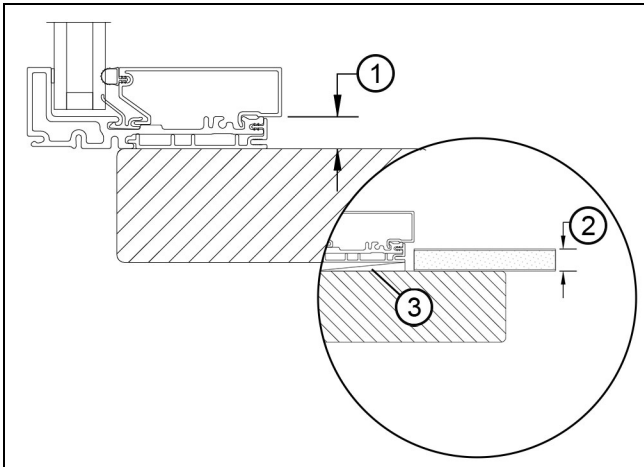

Figure 13

1	9/16" (14) gap between RO and cover (unshimmed)
2	5/8" (16) drywall and shimmed window
3	Shims



Figure 14

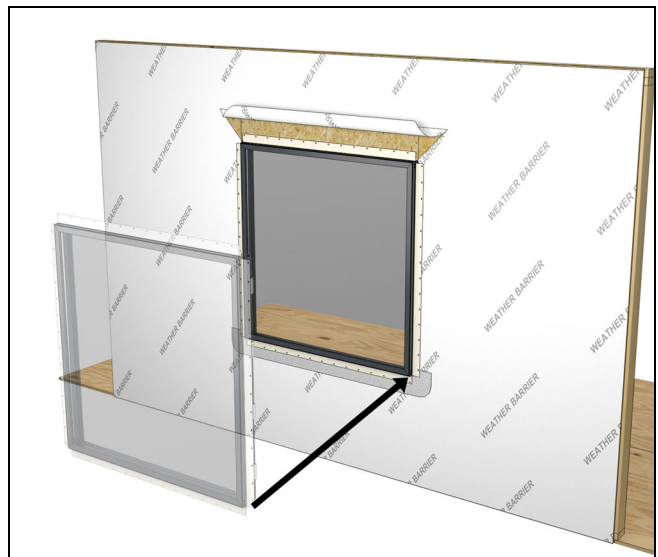

Figure 15

2. If you are mulling windows to the sides of a corner window, install the corner window first.

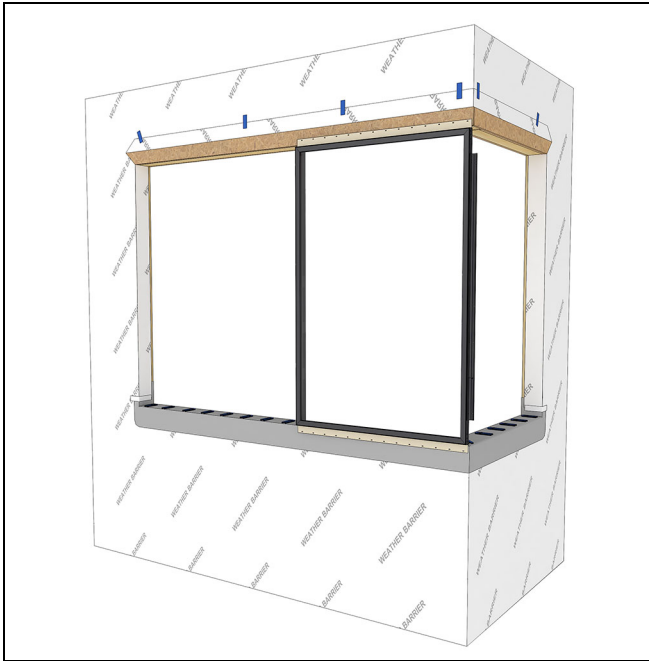

Figure 16

3. Before installing installation screws be sure to pre-drill into the rough opening with a long 1/8" drill bit.



Figure 17

4. Shim the bottom corners right above the fastener holes. Lightly fasten with the #10x3" installation screws provided. See Figure 18 and Figure 19.

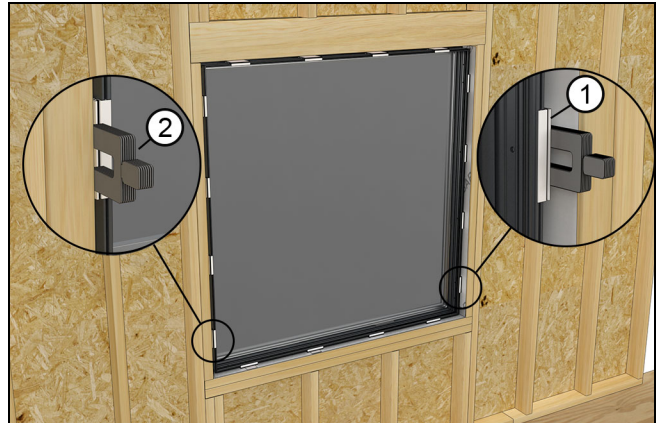

Figure 18

1	Shim block
2	Shim

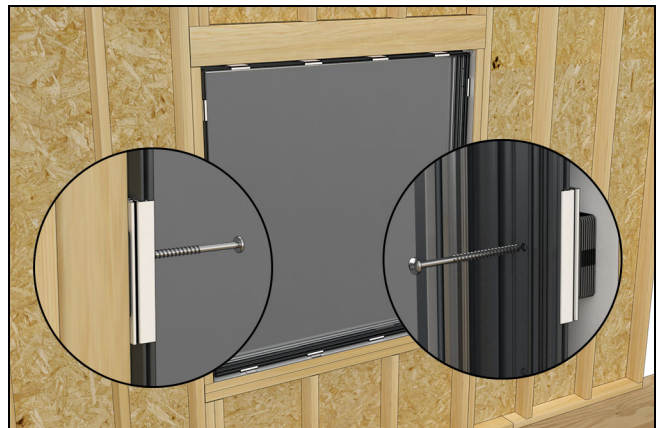

Figure 19

## ATTENTION

1 9/16" tripane units use a support clip at every setting block location. Access holes for the installation screws are provided through the clip and will line up with the holes on the frame. **It is extremely important that the support clip lines up with the glass setting block to provide adequate support for the weight of the glass.**

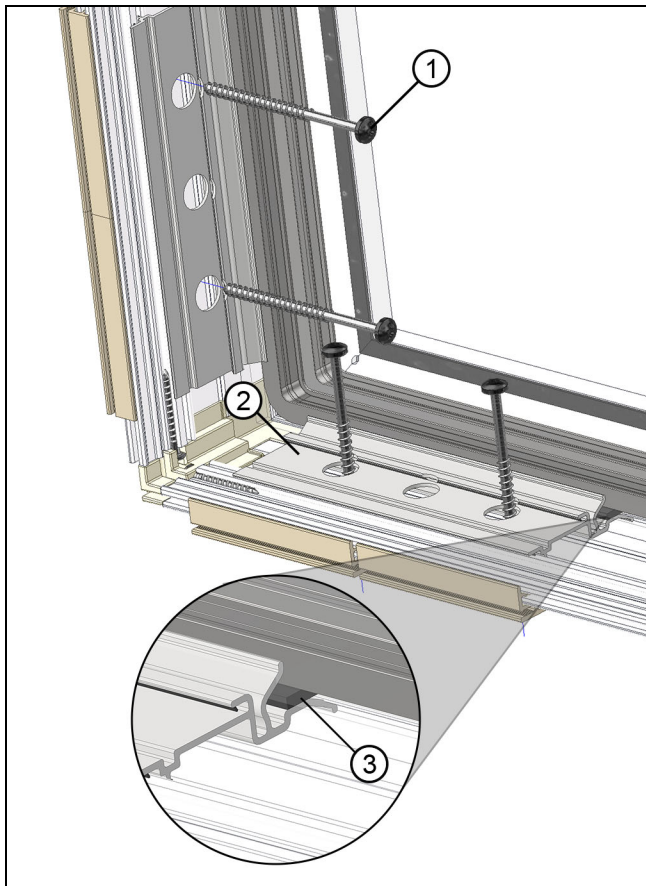

Figure 20

1	#10 x 3" Installation screws
2	Support clip
3	Setting block



### Hint

You may need to move the clip left or right to line up with the installation holes. Pry up on the clip from the interior then move the clip so the holes line up with the installation holes. Verify that the clip fully supports the setting block. It is extremely important that the support clip lines up with the glass setting block to provide adequate support for the weight of the glass.

5. Check for square and plumb (inside/outside). Adjust shims and screws accordingly. [See Figure 21.](#)



Figure 21

6. Shim and lightly fasten both jambs near the top using the #10x3" installation screws. [See Figure 22.](#)



Figure 22

7. If you are installing an assembly and mulling the units in the opening, install the A1 unit first, fastening at all locations (head jamb, sill, and one jamb) and then proceed to [Mulling on page 14](#). See [Figure 23](#).



Figure 23 First unit (A1) when mulling in an opening.

8. Check for square and plumb for the whole unit and then finish fastening at every pre-drilled hole in jambs, head jambs, and sill. See [Figure 24](#).



Figure 24 Single wide unit.

9. If you are **not** mulling assemblies, skip to the section: [Final Steps on page 21](#).

# Mulling

Using a smartphone or similar device, scan the QR code below or click [here](#) to play a video of this procedure.



Units are prepped for mulling and include an attached mull pin to the right hand jamb of the left side unit (A1 as seen from the exterior). Subsequent units at the middle of the mull will have the mull pin fastened to the right hand jamb at the factory. Units prepped for mulling will also have the shim spacers attached at the fastener locations, mull foam pads, and nailing fin where applicable. See Figure 25.

## IMPORTANT

A level and flat sill is crucial when installing and mulling units in the opening. The sill should be within 1/16" flat and level to achieve a successful mull and installation.

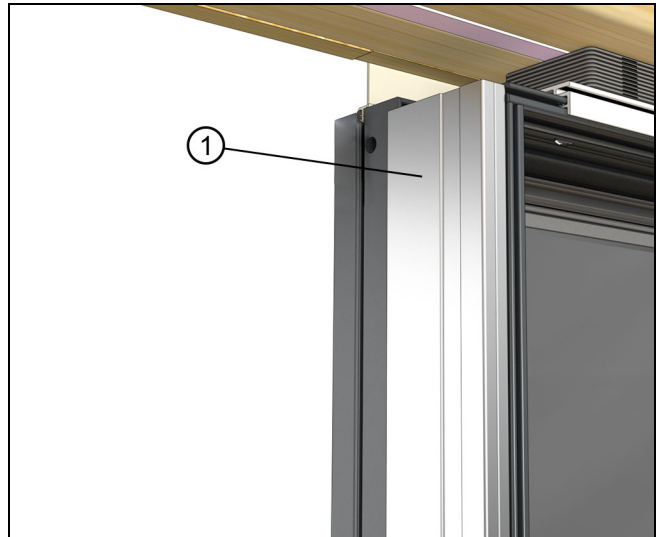

Figure 25 A1 units prepped for field mull (viewed from interior)

1	Mull pin (fastened from the inside of A1 unit)
2	Foam pads near nail fin kerf at top and bottom.

## Prep for Mulling

**NOTE:** If you are mulling an assembly in place set the first window (A1) in the opening and fasten the jamb, sill, and head jamb. See Figure 26. The illustrations that follow in this section show a 3-wide unit with two vertical mulls, mulled in the opening. If you are mulling the assembly before installation follow [step 1 on page 14](#) through [step 6 on page 17](#).

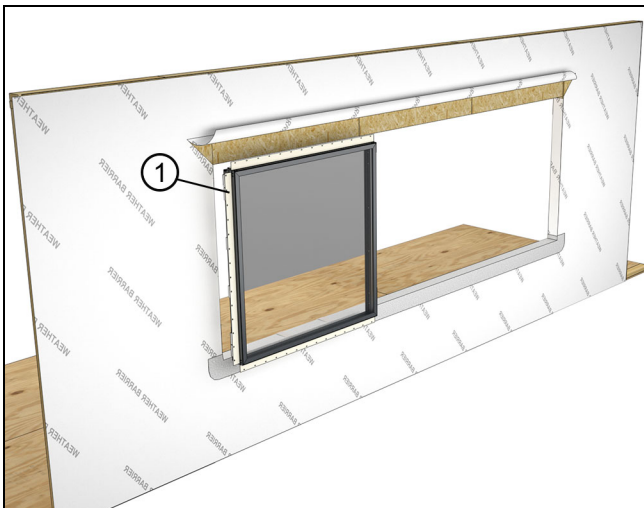

Figure 26 Install the first window (A1)

1	A1 (in mull configurations)
---	-----------------------------

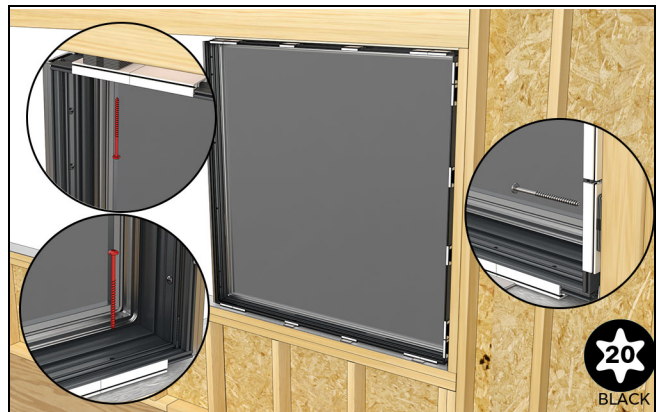

Figure 27

1. Apply a continuous 1/4" (6) bead of sealant along the length of the frame. See Figure 28.

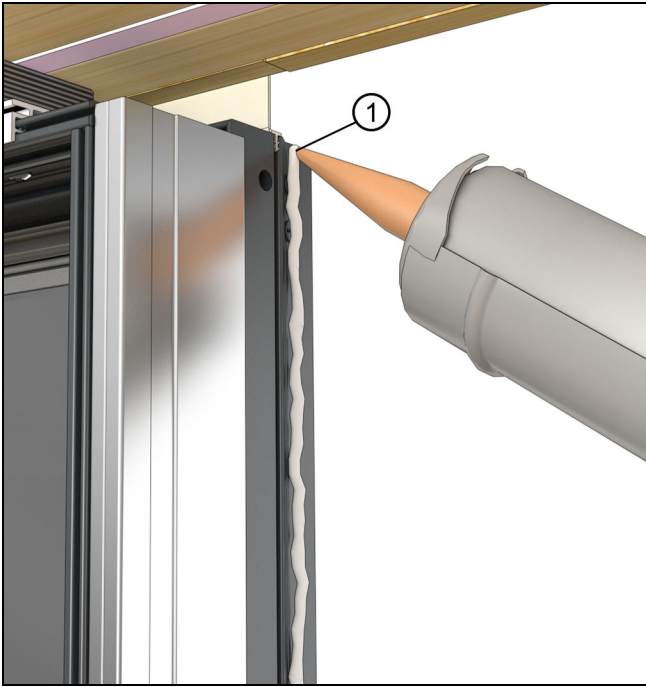

Figure 28

1	Apply sealant full length.
---	----------------------------

## Join the Assembly

### IMPORTANT

Make sure the sill is level and flat before installing and mulling assemblies.

1. Set the next unit close to the A1 unit. Clamp the two units together making sure the windows are flush to one another on all planes (interior/exterior and top and bottom). See Figure 29 and Figure 30.

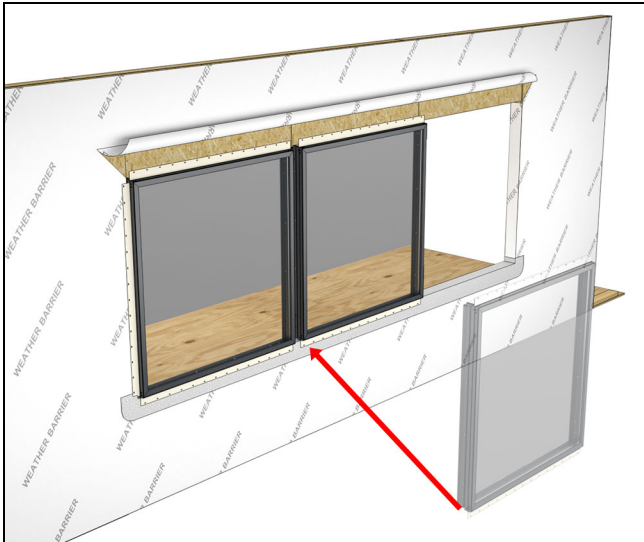

Figure 29

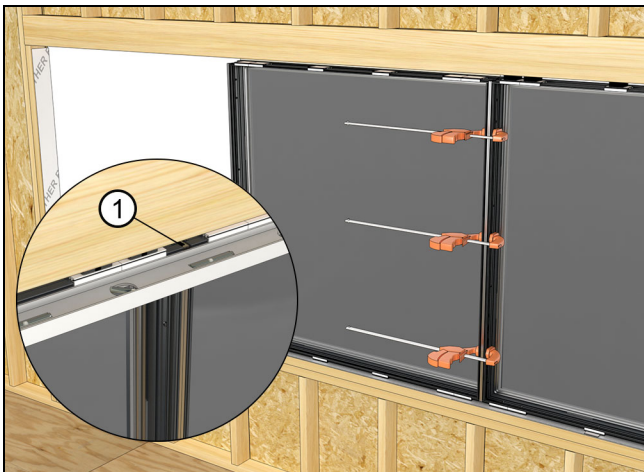

Figure 30

1	Flush the frames to one another.
---	----------------------------------

2. Fasten at each pre-drilled hole location with the #8 x 7/16" Phillips head self drilling screws provided. See Figure 31.

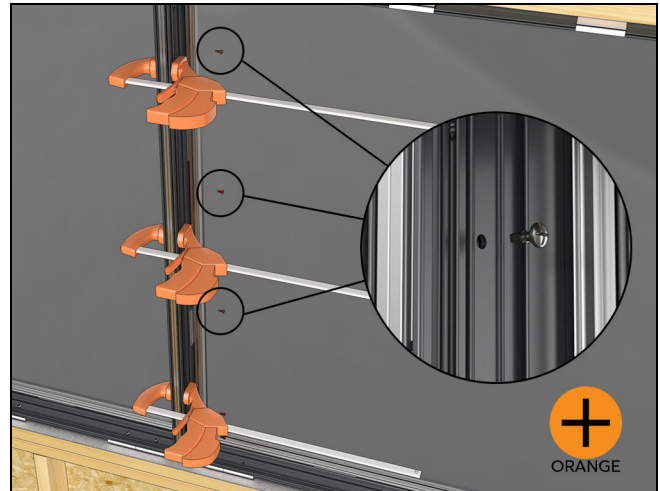

Figure 31

3. Apply the exterior covers. These can be seated with a rubber mallet. Make sure the covers are flush to the exterior accessory kerf. See Figure 32.

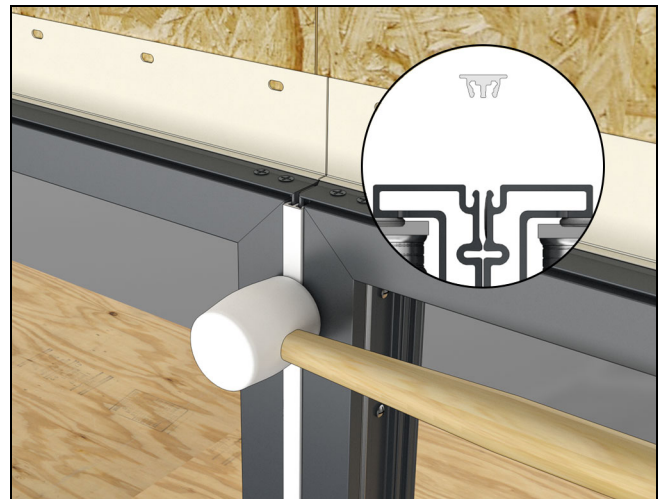

Figure 32



4. Fasten at the head jamb and sill with #10 x3" installation screws. Make sure the frame is plumb to the interior/exterior. See [Figure 33](#) and [Figure 34](#).



Figure 33



Figure 34

5. Apply the interior aluminum covers. These are barbed on and can be seated with a rubber mallet. Make sure the covers are flush to the interior accessory kerf. See [Figure 35](#).

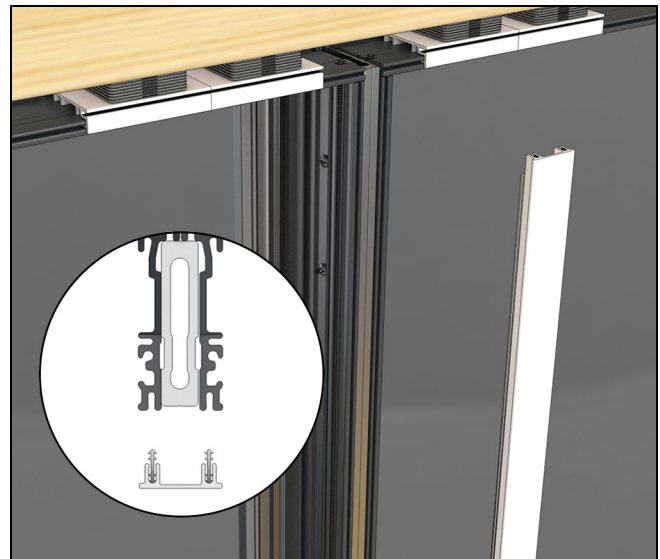

Figure 35

## IMPORTANT

Apply the mull caps between each window in multiple assemblies before joining the next window.

6. Repeat the previous steps until the entire assembly is complete. See [Figure 36](#).



Figure 36

## Horizontal Mulls

Use the techniques outlined in the previous sections to apply a horizontal mull. Install the lower units first. They will have the mull pin attached. Then set the top unit above, being careful not to disturb the sealant bead until you have the assembly aligned correctly. See [Figure 37](#).

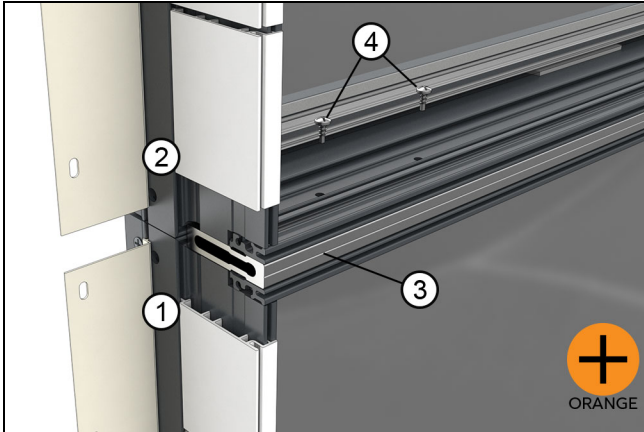
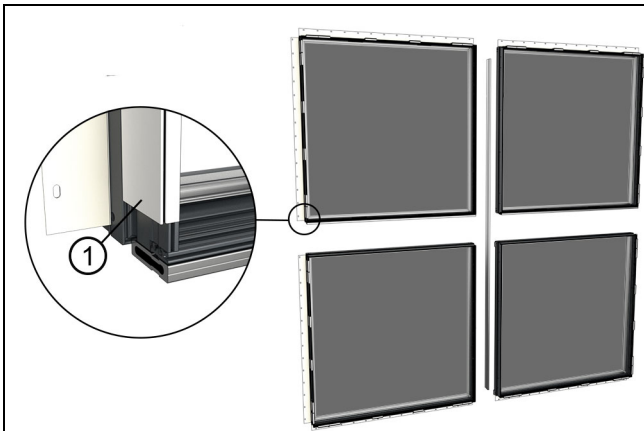

**Figure 37** Horizontal mull (framing not shown for illustrative purpose)

1	B1 unit
2	A1 unit
3	Mull pin
4	#8 x 7/16" Torx T20 self drilling screws

## Multiple High / Multiple Wide Assemblies

On multiple high/multiple wide assemblies a continuous mull pin must be applied to the mull direction with the shortest span. The non-continuous mull pins will be factory installed. Use the techniques outlined in the previous sections to mull the units with factory applied mull pins first. See [Figure 38](#).



**Figure 38** Multiple high and wide assemblies

1	Mull pin factory applied.
---	---------------------------

# Install Interior Covers

## Install the Jamb Covers

1. Slide the front of the frame cover (vinyl weather strip) into the frame kerf, rotate, and then push until the cover snaps into place. See [Figure 39](#) and [Figure 40](#).

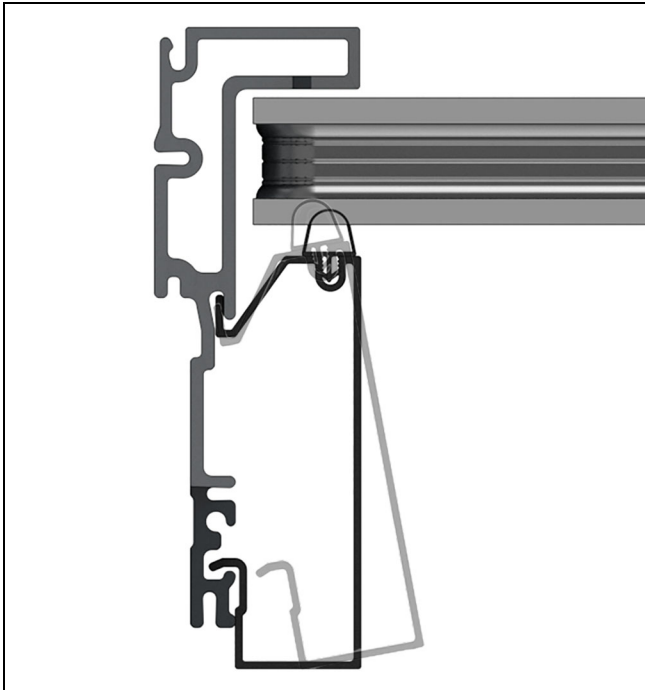

Figure 39 Rectangular covers



Figure 40

*NOTE: If you have a direct glaze window with angled legs such as a triangle or pentagon, skip to [Installing Covers on Angled Polygons on page 20](#).*

## Install the Head Jamb and Sill Covers

1. Slide the front of the frame cover (vinyl weather strip) into the frame kerf and then push until the cover snaps into place. See [Figure 41](#).



Figure 41

## Installing Covers on Angled Polygons

Covers for polygons such as triangles and pentagons go on differently from rectangular polygons. The covers on polygons with angled shapes go straight in, rather than rotated like rectangular units.

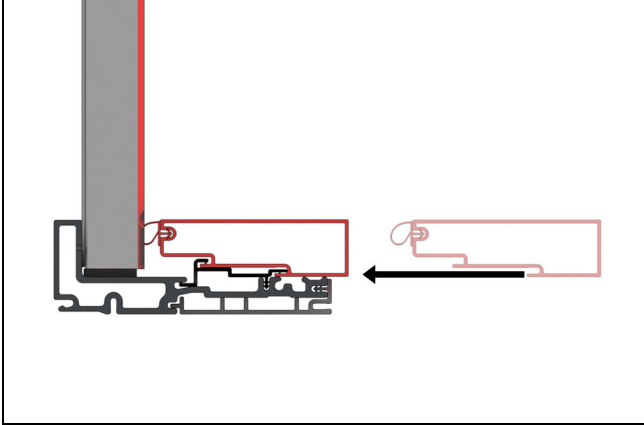

1. Use the chart below to determine the order in which the covers are applied based on shape.

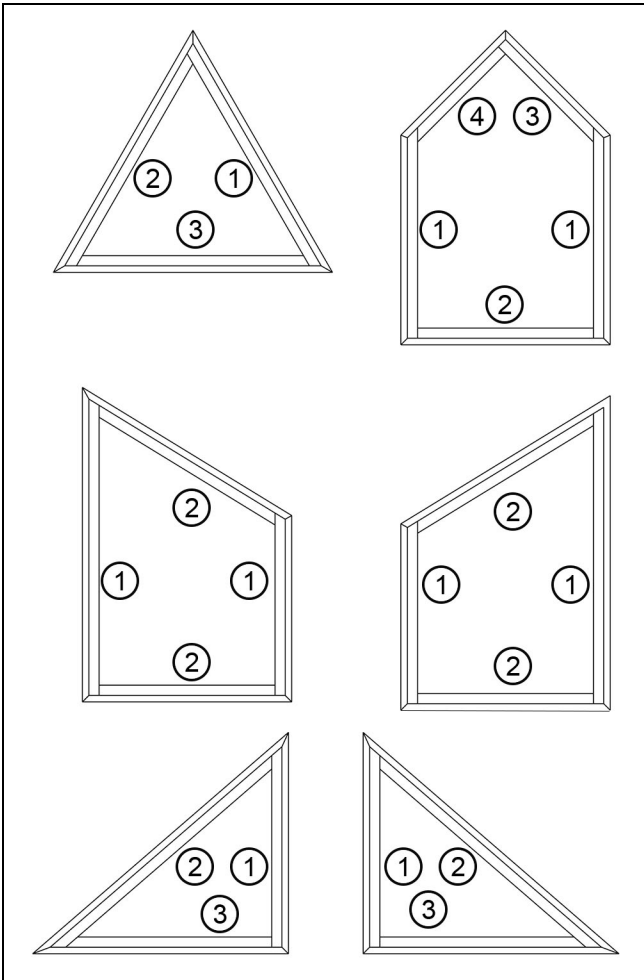

Figure 42

# Final Steps

## Flashing the Installation

Using a smartphone or similar device, scan the QR code below or click [here](#) to play a video of this procedure.



### IMPORTANT

Nailing fin is not designed to be a weatherproof flashing.

### IMPORTANT

Follow the flashing tape manufacturer's recommended instructions for attaching to the building materials under the WRB. For example, priming wet or frozen wood, application temperature, etc.

1. On units that use nailing fin, apply a 2" x 4" strip of flashing material at 45 degrees to the corner, bridging the gap between the nailing fin. Do this at all 4 corners. [See Figure 43.](#)

*NOTE: If your unit came with nailing fin corner gaskets, apply them according to the instructions sent with the packaging.*

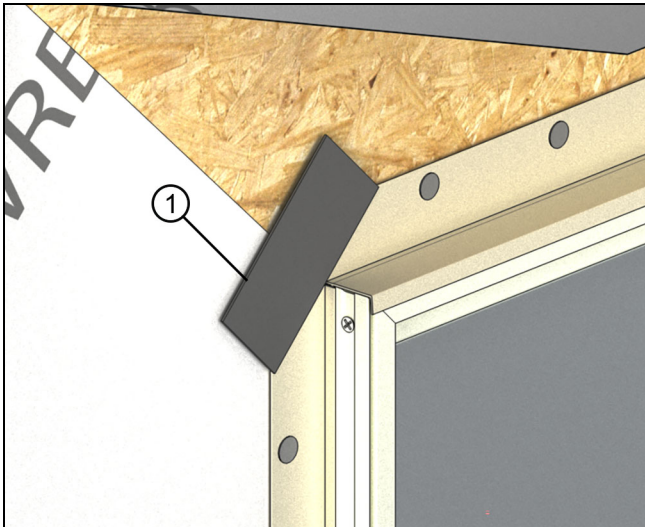

Figure 43

1	2" x 4" strip of flashing material
---	------------------------------------

2. **Optional:** Install a rigid head flash. Seal both horizontal and vertical legs of the rigid head flash. [See Figure 44.](#)

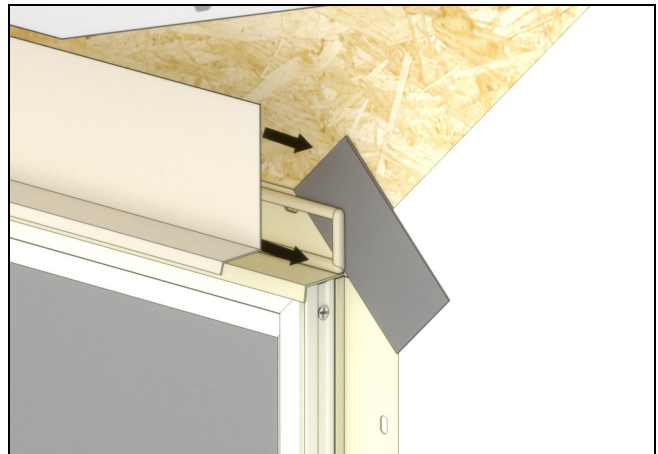

Figure 44

1	Sealant
2	Rigid head flash

3. **Optional Skirt:** Install an optional "skirt" in applications with exposure to wind driven rain/climate. Use flashing material or a 12" (305) strip of WRB and attach to the sill of the window with seam seal tape or flashing tape. [See Figure 45.](#)



Figure 45

1	Skirt (WRB material or other)
2	Adhesive tape
3	Attached to sill of window

4. Lap vertical strips of adhesive flashing tape onto the unit and out over the WRB. Make small diagonal cuts at the head jamb as in [Figure 46](#) to allow the membrane to fold back onto the exterior and frame.

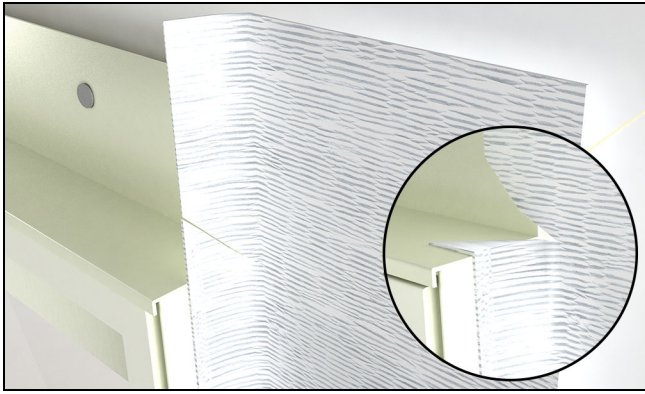

Figure 46

5. Install another layer of adhesive membrane lapping onto the head jamb of the unit and over the sheathing. The membrane flashing at the head jamb should extend and cover the flashing previously installed at the jambs. Make relief cuts and fold down so that it wraps around the jamb See Figure 47 and Figure 48.

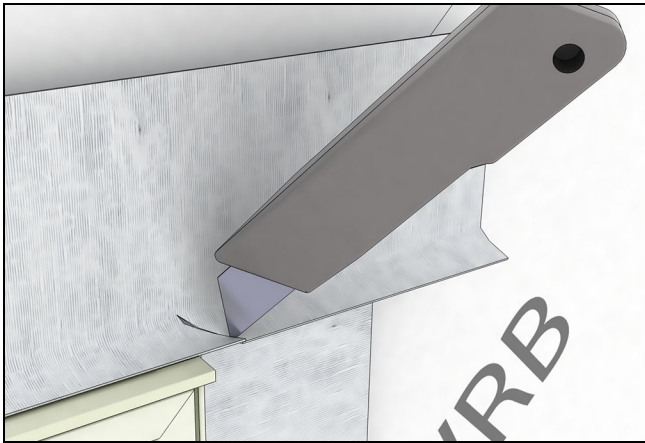

Figure 47

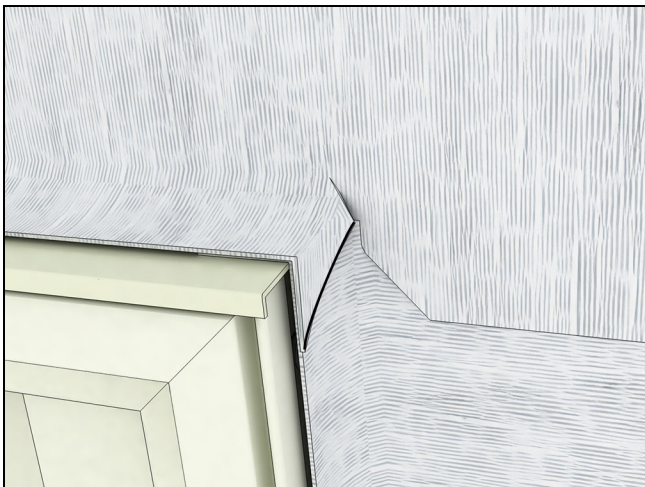

Figure 48

6. Tape the top edge of the head jamb flashing with seam seal tape. See Figure 49.

*NOTE: This does not apply to self adhered WRB.*



Figure 49

7. Seal the ends of the rigid head flash by injecting sealant at each end. See Figure 50.

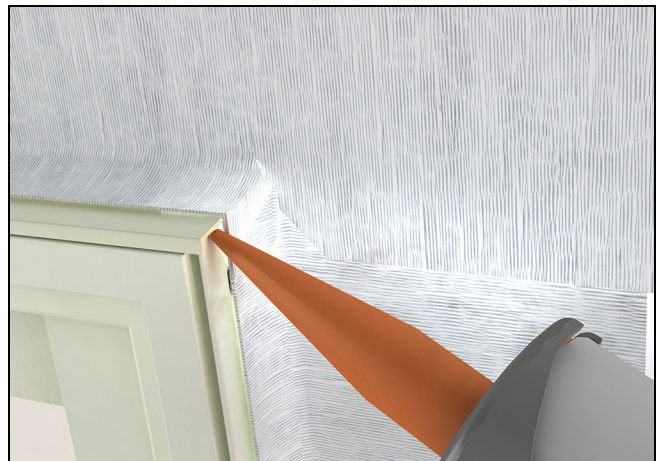

Figure 50

8. Fold the head jamb WRB down over the head jamb flashing. Apply seam seal tape over the diagonal cut in the WRB. Make sure the seam seal tape laps onto the unit or casing. Tape any seams and fasteners directly above the unit with seam seal tape. See Figure 51.

*NOTE: This does not apply to self adhered WRB.*



**Figure 51**

## Insulating and Sealing the Installation

1. Apply insulation in the rough opening, against the backer rod installed earlier. Seal all joints where drywall returns to the window frame. See Figure 52.

### IMPORTANT

Do not install drywall over the interior frame cover. This will hinder the ability to remove the cover later. When applying sealant between the cover and drywall, use a paintable caulk.

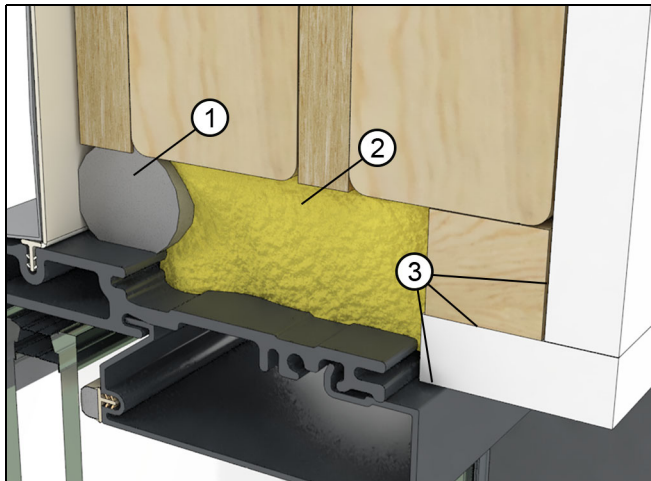

Figure 52

1	Exterior backer rod
2	Insulation
3	Sealant

2. At the exterior, once the exterior finish such as siding or brick veneer is installed, apply a bead of sealant between the finish and the frame exterior along the sides. Apply additional beads approximately 1"-2" (25-51) at the ends on top of the head jamb flashing. Use a backer rod when necessary. See Figure 53 and Figure 54.

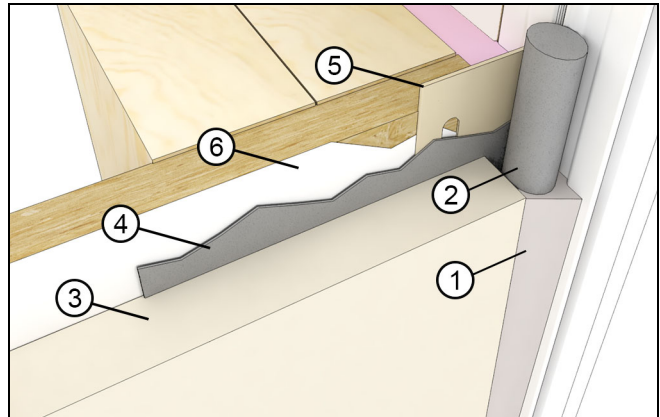

Figure 53



Figure 54

### ! CAUTION!

Perimeter sealant must be Grade NS Class 25 per ASTM C920 and compatible with the window product and the finished exterior(s) of the building. Using improper sealant could result in sealant failure causing air and water infiltration.



# Technical Specifications

The following details are specified for proper installation of the unit to meet the advertised performance grade (PG) rating.

- Rough Opening Width: 1/4"-1 1/2" (6-38) wider than unit frame outside measurement.
- Rough Opening Height: 1/4"-1 1/2" (6-38) taller than unit frame outside measurement.
- Masonry Opening Width: 1/4"-1/2" (6-13) wider than unit frame outside measurement.
- Masonry Opening Height: 1/8"-1/4" (3-6) taller than unit frame outside measurement.

## ATTENTION

**Architectural Detail Manual Specifications:**  
Rough Opening: Width up to 1 1/2"(38); Height up to 3/4" (19)

Masonry Opening: Width 1/4"

- The panning must drain water to the exterior of the cladding OR the exterior surface of a concealed weather resistive barrier.

## ! CAUTION!

Be aware that the use of sill pans and other barriers will decrease the rough opening height clearance. Adjust opening dimensions accordingly.

- The panning system used in these instructions is one component in a structure's overall water management system. It should be used in conjunction with an appropriate drainage plane compatible with the exterior wall cladding.
- Flashing materials must comply with ASTM E2112, and be compatible with all materials used in installation including panning systems, air barriers and building papers, sheathing, and the window unit.
- Properly flash and/or seal all windows at the exterior perimeter.

## IMPORTANT

Flashing material must not contain asphalt and must be compatible with flexible PVC (vinyl) if nailing fin is used as a backing material.

## IMPORTANT

Sealants used for installation must be Grade NS Class 25 per ASTM C920 and compatible with the building exterior, window or door exterior surface, and flashing/water management materials.

- Optional foams used for installation must be low expansion only. Foam and foam application must comply with ASTM E2112.
- Shims are required at every fastener location.
- Do not use chemically treated products for shim material.
- Fasteners penetrating chemically treated lumber must be a minimum of 0.90 oz/ft<sup>2</sup> zinc hot dipped galvanized or stainless steel type 304 or 316.
- The frame must not come into direct contact with chemically treated wood products.