

Modern Multi Slide-Stacked Installation Instructions

Related Documents

Quick Start Guide

ABSTRACT: Please read these instructions in their entirety before beginning to install your Marvin Door product. These installation instructions demonstrate the installation of a Marvin door in new wood frame construction using an industry approved water management system. For installation using other construction methods, such as remodeling, replacement, and recessed openings refer to the latest version of ASTM E2112, "Standard Practice for Installation of Exterior Windows, Doors and Skylights," for installation suggestions. The same information for ASTM E2112 can be found on the ASTM website, www.astm.org.

Regional standard practices, environmental conditions, and codes may vary and supersede the procedures contained within. The responsibility for compliance is yours: the installer, inspector, and owner(s).

The English language version of this instruction is the official version and shall take precedence over any translation.

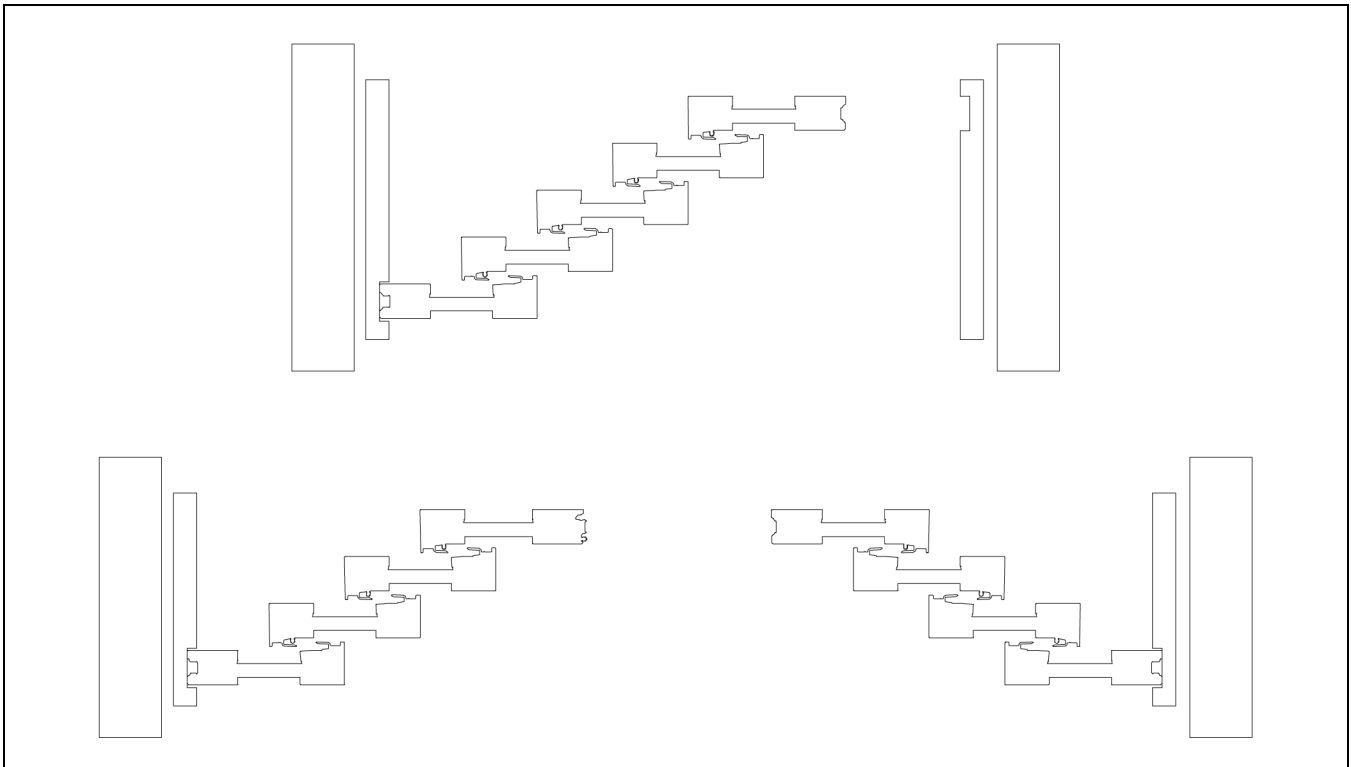

KEYS TO A GOOD INSTALLATION:

- SQUARE the door in relation to the sill.
- A GOOD INSTALLATION has a FLAT sill that is also LEVEL.
- The BEST INSTALLATION has a FLAT and LEVEL sill and a SQUARE and PLUMB opening.

Correcting an out of square opening requires shimming beneath the sill and/or at the corners. These instructions assume an opening is constructed for the BEST installation with a flat and level sill and a square opening.

NOTE: Numbers listed in parentheses () are metric equivalents in millimeters rounded to the nearest whole number.

Table of Contents

Hazards and Warnings.....	3
Protective Film	4
After Market Products	4
Installer and Builder Information	5
Tools Needed	5
Parts Included	6
High Performance Sill-Install the Sill Slope.....	7
Install Panning	9
High Performance Sill-Install the Counter-shims	9
Splicing the Sill.....	10
Splicing the Head Jamb	14
Assemble the Frame.....	17
Install the Frame	18
Squaring the Frame and Complete Fastening	20
PANEL INSTALLATION.....	25
Identifying Panels.....	25
Stationary Panel Prep	26
Panel Installation-Standard Configurations.....	28
OX-O or O-XO Panel Installation	32
OOX, XOO, OOOX, and XOOO Panel Installation	37
OX-XOO or OOX-XO Panel Installation.....	42
XOX Panel Installation	47
XOOX Panel Installation	50
Install Sill Frame Covers	55
Install Head Jamb Frame Covers	56
Install Jamb Frame Covers	57
Adjusting Panels	58
Install the HP Nosing.....	60
Technical Specifications	61

Hazards and Warnings

WARNING!

Do **NOT** lift or move without proper equipment. Read, understand, and follow all lift equipment manufacturers' instructions and safety information.

WARNING!

This product can expose you to chemicals including titanium oxide, which is known to the state of California to cause cancer. For more information, go to www.P65Warnings.ca.gov.

WARNING!

This product can expose you to chemicals including methanol, which is known to the state of California to cause birth defects or other reproductive harm. For more information, go to www.P65Warnings.ca.gov.

WARNING!

Always practice safety! Wear the appropriate eye, ear, and hand protection, especially when working with power tools.

WARNING!

Pinch point can occur at the panel intersections during operation. Do not keep fingers in the exterior pull when bypassing the adjacent panel.

CAUTION!

Wear gloves and protective clothing when handling the frame components. Some high-density fiberglass surfaces are not coated and can leave splinters in bare skin.

NOTE: Multi-Slide panel operation force is affected by panel size and number of panels. Keep this in mind when having to open or close large and/or multiple panels at one time.

Protective Film

Some products feature a clear protective film adhered to the glass surfaces to protect them from construction debris, dust, dirt, stucco, etc. When construction is complete, simply peel the film off and dispose of it with other construction debris.

IMPORTANT

Do not use a razor blade to remove the protective film. Do not use a pressure washer to clean debris from the film. The film should be removed within nine months (typical) of application.

The use of high absorption coatings and tints, Neat+® coated glass, LoE-189® and other exposed Low-E coatings could affect adhesion and reduce the amount of time allowed to remove the film. Please refer to the [manufacturer's website](#) and [bulletin](#) for more information on the physical properties and usage of the protective film.

IMPORTANT

DO NOT place suction cups over seams in the protective film.

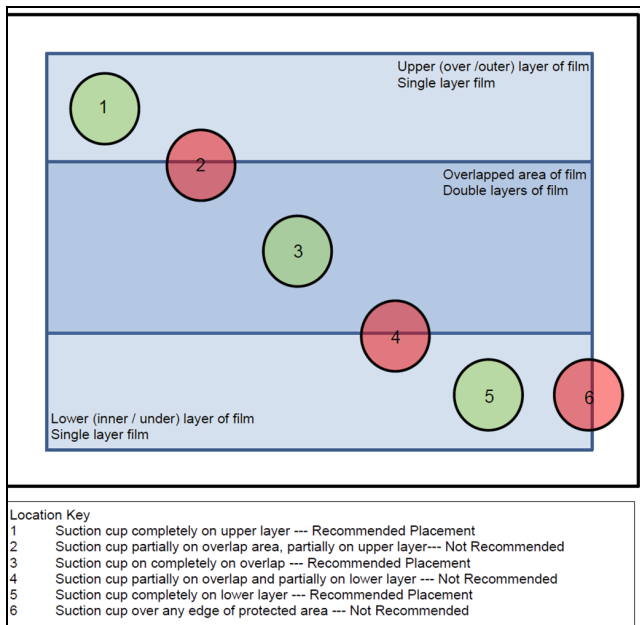

Figure 1 Do not put suction cups on seams or edges

After Market Products

Alterations to Marvin products including window films, insulating or reflective interior window treatments or additional glazings can cause excessive heat buildup and/or condensation. They may lead to premature failures not covered under warranty by Marvin Windows and Doors.

Before purchasing or applying any product that may affect the installation or performance of Marvin windows or doors, contact the manufacturer of after-market product/glazings that are not supplied by Marvin and request written product use, associated warranties and damage coverage. Provide this information and warranties to the end user and/or building owner for future reference.

Installer and Builder Information

- Always provide a copy of these instructions for the current homeowner.
- Plan sizing of rough opening and clearance from exterior finishing systems to allow for normal materials shrinkage or shifting (e.g. wood structure with brick veneer; allow adequate clearance at the sill). Failure to do so can void the Marvin warranty coverage.
- Refer to the Technical Installation Specifications section for technical specifications regarding the installation of this product. These installation requirements as well as the details in the section must be followed to achieve the advertised Performance Grade (PG) rating of this product.
- It is the responsibility of the builder, installer, and subcontractors to protect the interior and exterior of windows or doors from contact with harsh chemical washes, construction material contamination and moisture. Damage to glazing, hardware, weather strip and cladding/wood can occur. Protect with painters tape and/or protective sheathing as required. Follow all guidelines regarding material use, preparation, personal safety and disposal.
- Contact your Marvin supplier if you have any questions regarding product and materials used in manufacturing or questions on replacement parts.
- Please refer to the PDF version of this instruction for further information regarding best practices installer and builder information, code, and other legal requirements. The PDF version is the official document of record.

Tools Needed

- Safety glasses
- Putty knife
- Pry bar
- Square
- Drill/driver
- T20 Torx and #2 Phillips bits
- 5mm Hex wrench at least 5"
- 1/8" drill bit
- 3/16" drill bit
- 1/8" self centering bit (Vix bit)
- Gloves
- Flathead screwdriver
- Suction cups for handling glass panels
- Utility knife
- Level (laser level helpful)
- Rubber mallet
- Tape Measure
- Mason's line
- Compressed air

Additional Supplies Needed

NOTE: Some supplies are sent with your door. Refer to the picklist in the Installation and Hardware Accessories Box for details.

- Story poles (if necessary)
- Low expansion, low compression foam
- Flashing
- Sealant
- Sill Pan
- Weather resistive barrier
- Shims
- Rags/paper towel
- Minimum #8 size screws to fasten sill to rough opening (length depends on substrate).

Parts Included

Each door is shipped with panels, frame components, weatherstrips etc. Fasteners are sent in color coded packages noted below and throughout the instruction in the illustrations.

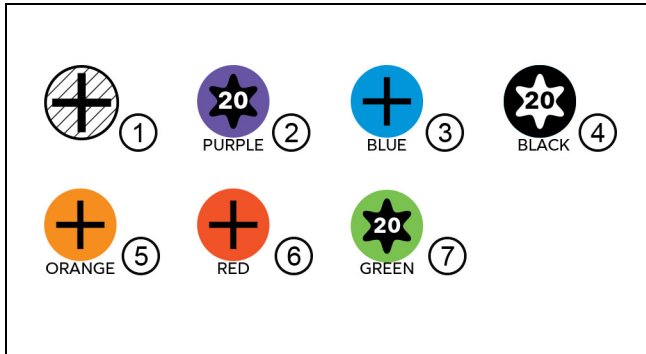

Figure 2 Color coded screw packages

1	Phillips Head, no package
2	#8x1/2" T-20 Torx head, purple package
3	#8x3" 2/3 thread Phillips head, blue package
4	#10 x 3" T-20 Torx 2/3 thread pan head screw, black package
5	#8x7/16" self drilling Phillips pan head, orange package
6	#8x1/2" Phillips flat head stainless screw, red package
7	#8x 1 3/4" self drilling T20-Torx pan head stainless steel, green package

High Performance Sill-Install the Sill Slope

Using a smartphone or similar device, scan the QR code below or click [here](#) to play a video of this procedure.



NOTE: If you are installing a door with a standard flush sill or performance sill proceed to [Install Panning on page 9](#).

If you are using a high performance sill, you will receive the Sill Slope pre-assembled and counter-shims that are snapped together as well as fasteners. After the sill opening is leveled you will install the Sill Slope, then your panning, counter-shims, and finally install the frame. [See Figure 3](#).

IMPORTANT

Sill opening cannot exceed 1/4" out of level. You must remedy the sill opening condition to within 1/4" of level before installing the sill slope.

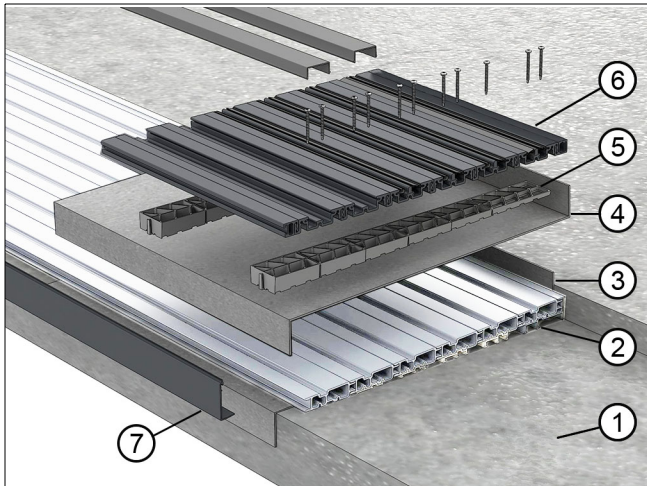

Figure 3 HP Sill System

1	Sill Slot
2	HP Sill Slope
3	Optional pre-panning/sill leveling
4	Panning
5	Countershims
6	MSD door sill
7	Sill nosing

1. Temporarily place the HP **sill** component next to the opening. Mark the location of the holes on the RO subsill. This will help you locate the counter-shims. [See Figure 4](#).

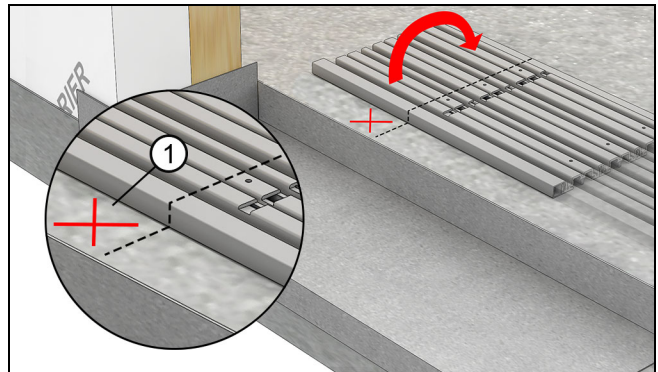

Figure 4

2. Set the sill slope in the slot at the desired location. Using the pre-drilled holes in the sill slope as a guide, drill through both walls of the sill slope and into the optional pre-panning and substrate. [See Figure 6](#) and [Figure 6](#).

The sill slope is oriented flush with the exterior nail fin plane or 1 1/16" (29) from the exterior plane of the door.

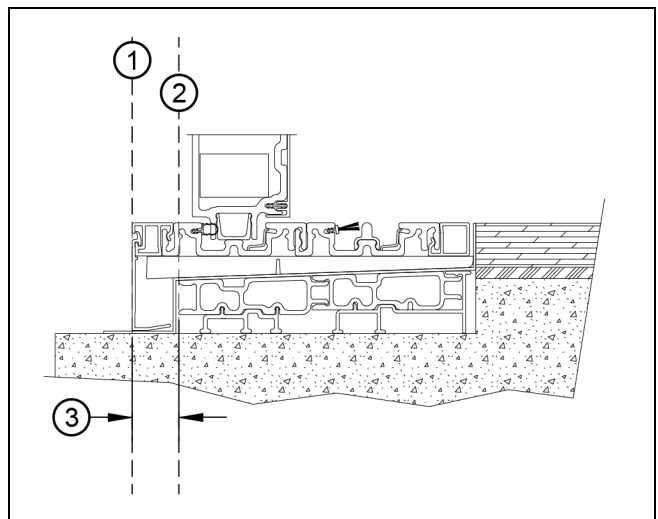

Figure 5

1	Exterior plane of door
2	Exterior nose of sill slope
3	1 1/16" (29)

NOTE: The sill slopes is cut to the width of the opening, it can be trimmed shorter if needed to fit the actual opening.

NOTE: Temporarily place shims between the sill slope and the interior edge of the slot to maintain a 1/8" gap and help to mark the location of the slope once you remove it from the slot.

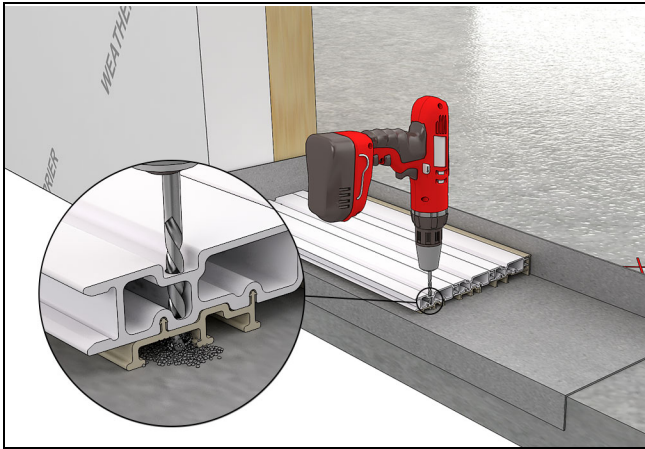

Figure 6

3. Remove the sill slope from the slot and blow out the holes with compressed air. See Figure 7.

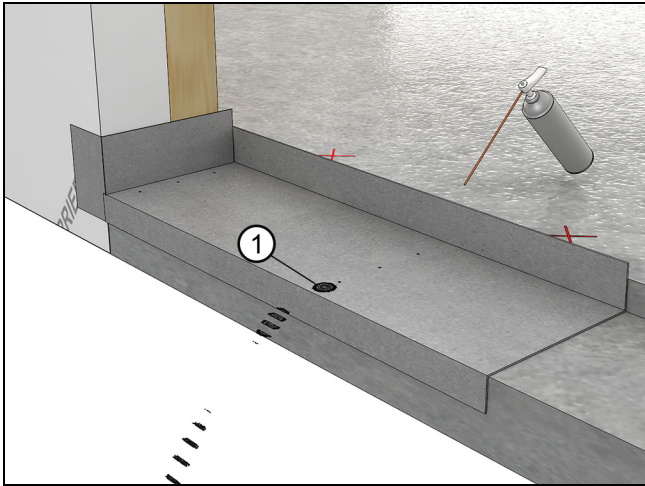

Figure 7

1	Blow debris out of hole
---	-------------------------

4. Inject the pre-drilled holes with sealant. See Figure 8.

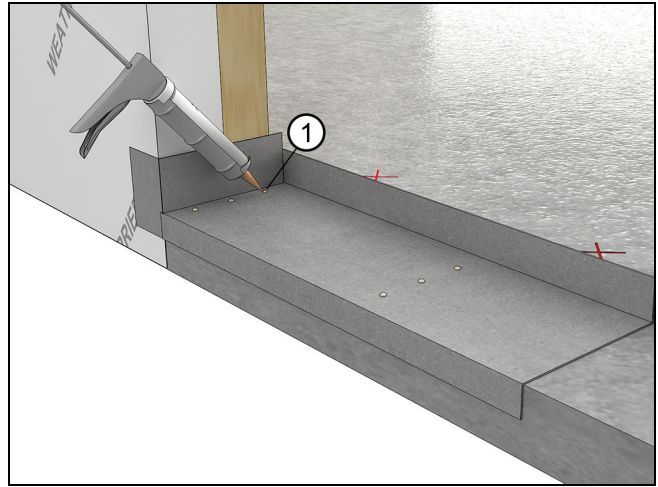

Figure 8

1	Sealant
---	---------

5. Set the sill slope in the slot and fasten into the rough opening sill with a minimum #8 x 2 1/2" (64) pan head screw appropriate for your structure. The screw must penetrate at least 1 1/4" (32) into the subsill. See Figure 9.

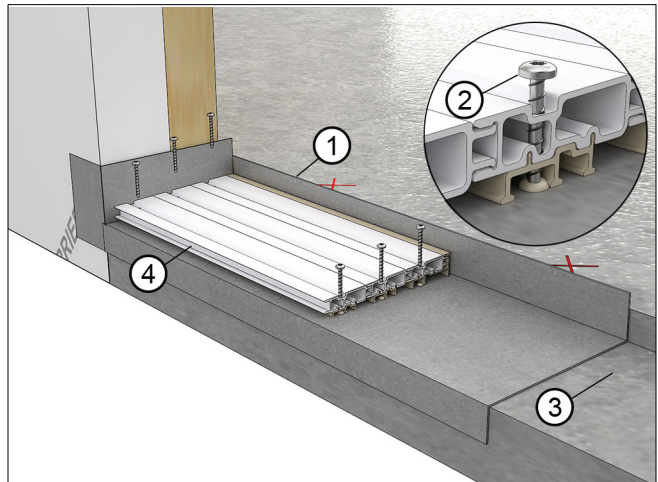

Figure 9 Install sill slope

1	Optional pre-pan
2	Fastener-#8 size at least 2 1/2"
3	Slot
4	Sill Slope

Install Panning

1. Integrate your panning with the water management system.
2. Any fasteners penetrating the sill panning must have sealant applied to the pre-drilled hole prior to fastening.
3. All pannings for stacked configurations must have an end dam as high as the rear sill liner and sides that come up at least 4"(102). See Figure 10.

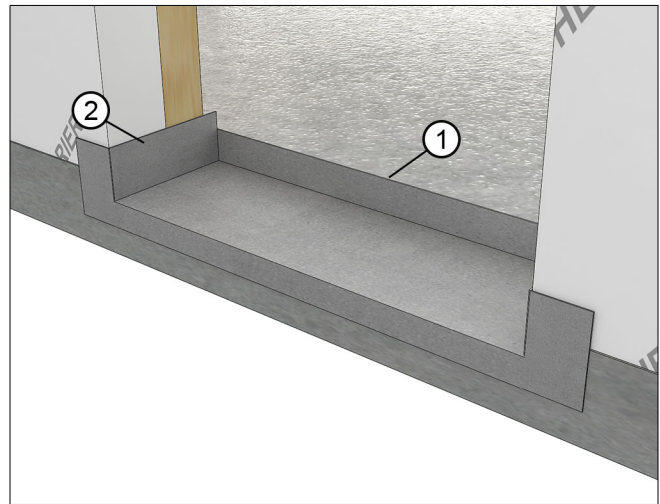

Figure 10 Stacked Panning for Performance or Flush sill shown.

1	Interior end dam must be as high as the sill liner on the door.
2	Sides must come up at least 4"

High Performance Sill-Install the Counter-shims

1. Assemble the counter-shims sent with the door. See Figure 11.

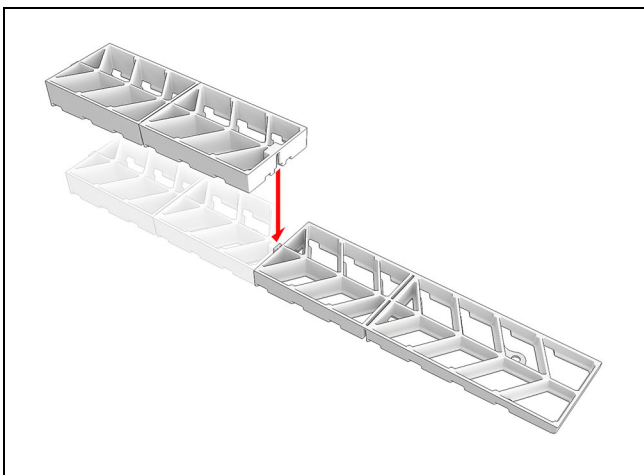

Figure 11 Connect counter-shims

2. If you have an odd number of sill tracks you will need to break off the exterior end of the counter-shim at the break line. See Figure 12.

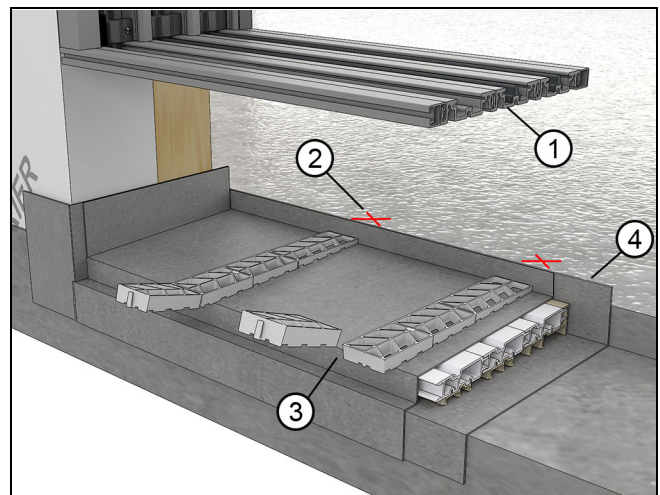

Figure 12 HP Sill (3 track shown)

1	Door sill
2	Sill dam
3	Counter shim
4	Optional pre-panning

3. Place the counter-shims in the panning every 10"(254) using the marks you made earlier as a guide. The counter-shims should be placed beside the fastener locations (opposite side of the drain routes). See Figure 13.

Hint

Put a dab of sealant down to keep the counter-shims in place before you install the frame.

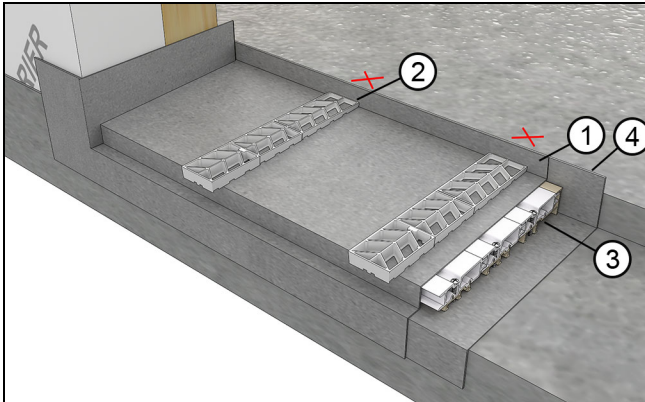

Figure 13 Set counter-shims

1	Panning
2	counter-shims
3	Sill Slope

4. Check the counter-shim/sill opening for level. If necessary use the 1/16" (3) thick adhesive backed shims (included) to bring the counter-shims to level. See Figure 14.

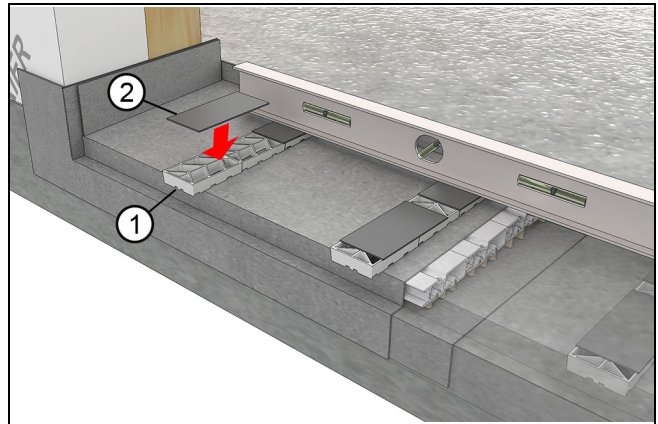

Figure 14 Level counter-shims with stackable shims

1	Counter shim
2	Stackable shims

Splicing the Sill

Using a smartphone or similar device, scan the QR code below or click [here](#) to play a video of this procedure.



NOTE: You will have to splice your sill if the width of your door exceeds 21 feet (6.4 meters).

1. Spliced sills will be labeled to provide detail on where you need to install the various bundled components in [step 11 on page 13](#). A key is also provided for further detail on the component, track, and location.

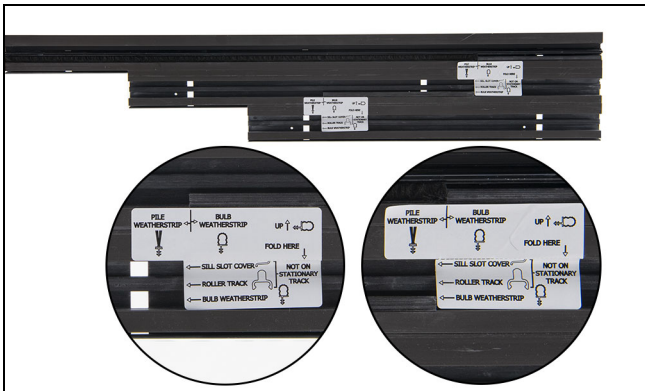

Figure 15



Figure 16

2. Lay the sill parts on a flat clean and protected surface with the splice sections lined up top side up. See Figure 17.

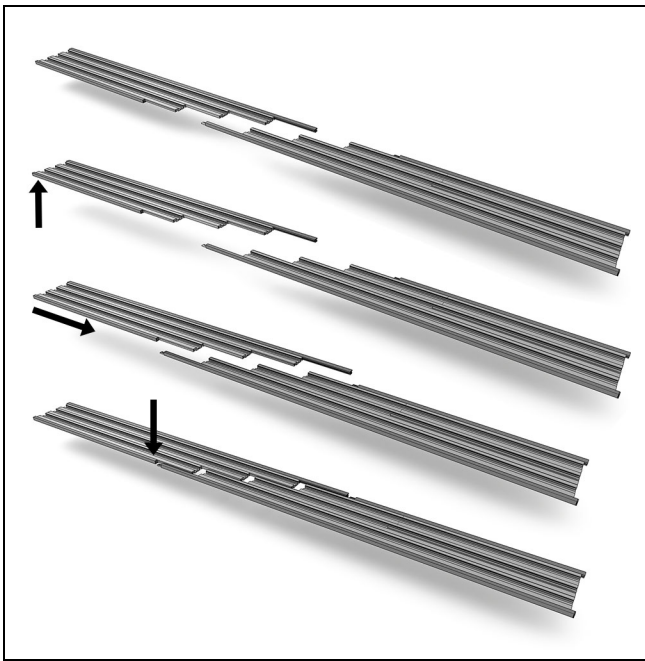

Figure 17

3. Press the splice sections together and seat with a rubber mallet. See Figure 18.

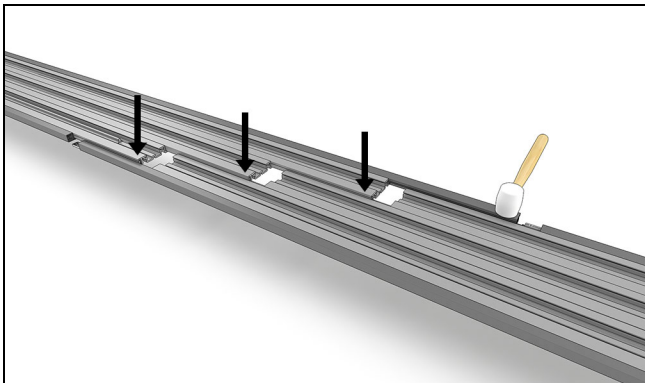

Figure 18

4. Flip the assembly upside down. See Figure 19.

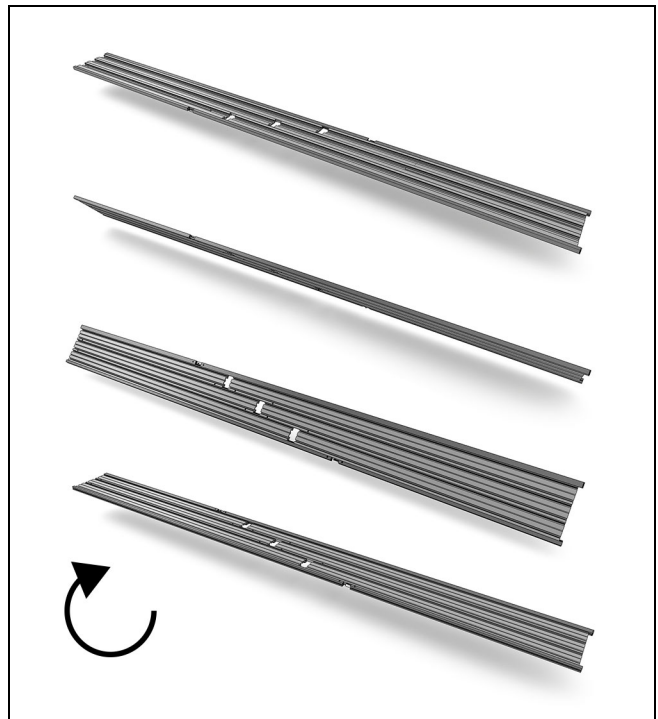

Figure 19

5. Remove the screws from the splice keys. See Figure 20.

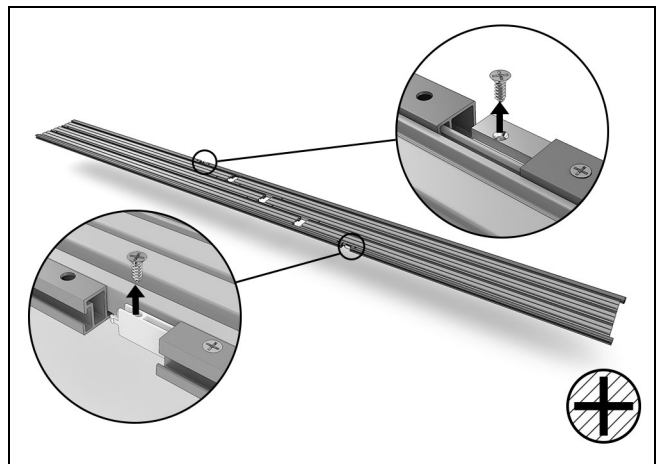

Figure 20

6. Tap the two sections together until the splice joint is tight and the end of the tracks are flush. The sill liners will sit 1/2" (13) beyond the tracks on each side of the sill. See Figure 21.

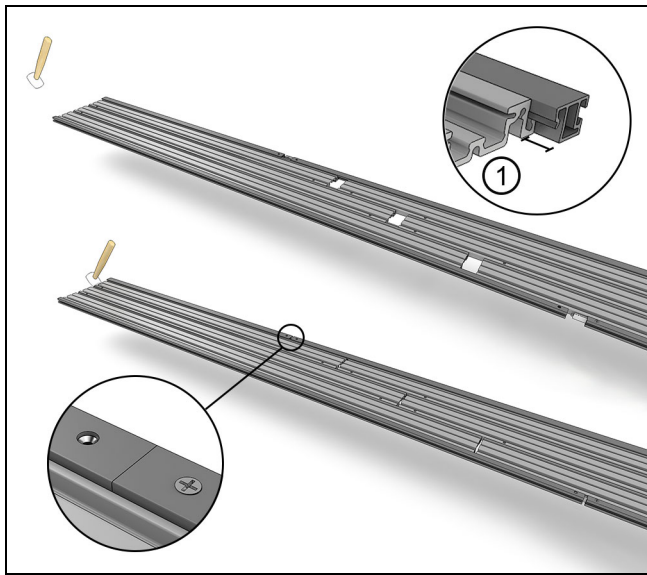

Figure 21

1	1/2" (13)
---	-----------

7. Fasten the splice keys with the screws you removed earlier. [See Figure 22.](#)

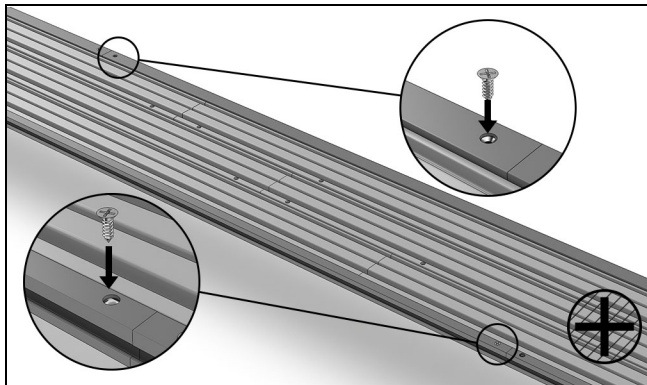

Figure 22

8. Drill pilot holes through the pre-drilled holes (found near the splice areas) using a 1/8" (3) Vix (self centering) drill bit. **The depth cannot exceed 1/2" deep.** [See Figure 23.](#)

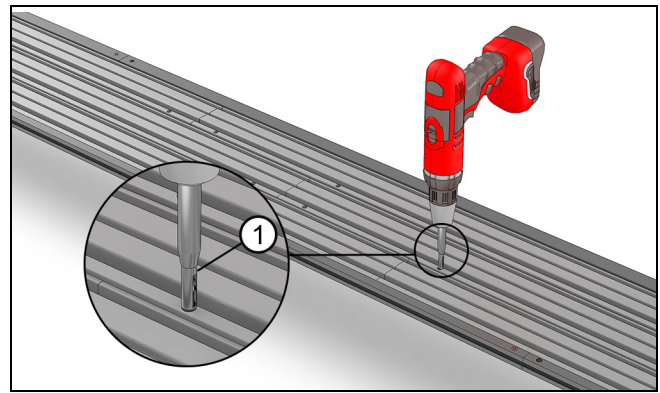

Figure 23

1	1/8" Self centering drill bit.
---	--------------------------------

9. Fasten sill sections with #8-18 x 1/2" (13) screws.

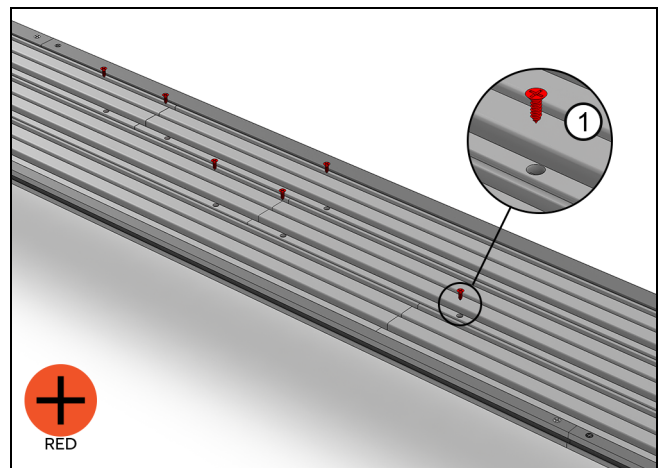

Figure 24

1	#8x1/2" screws
---	----------------

10. Once all screws are secured, flip the sill right side up. [See Figure 24.](#)

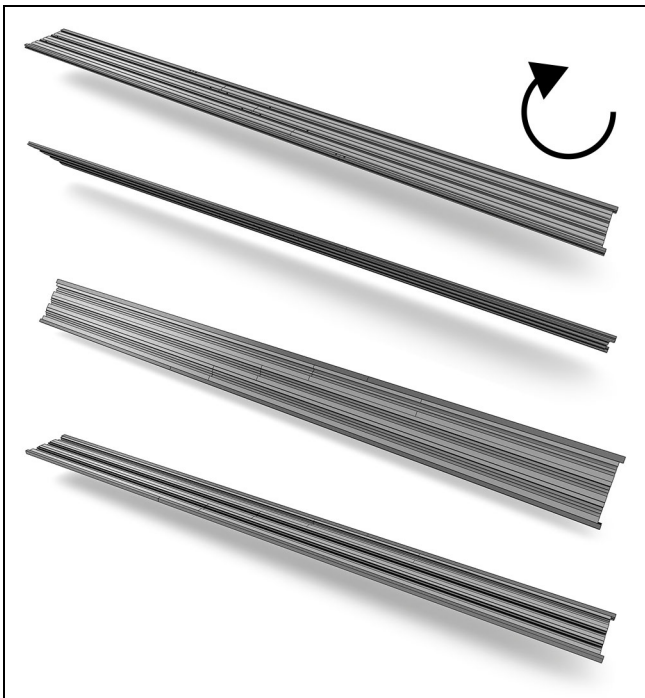

Figure 25

11. Where required, add the roller track, weather strip and sill slot covers over the spliced sections. See Figure 26, Figure 27, and Figure 28.

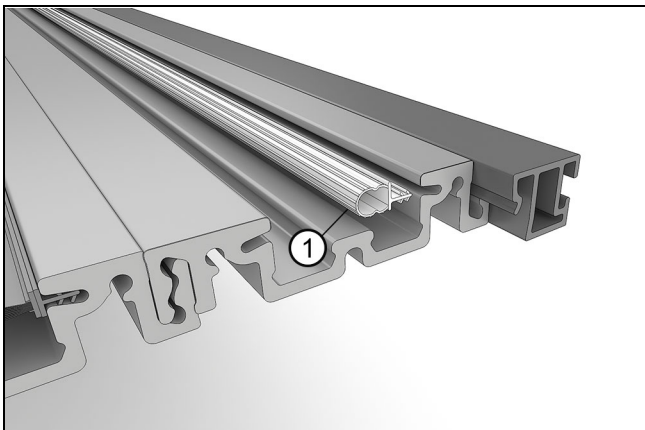

Figure 26

1	Bulb weather strip
---	--------------------

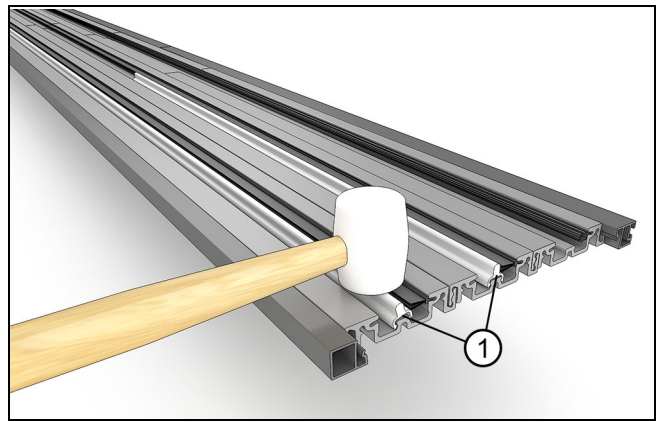

Figure 27

1	Sill track
---	------------

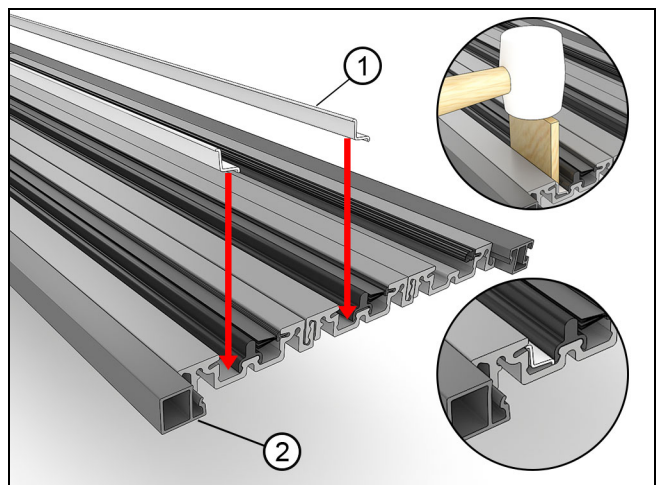

Figure 28

1	Sill slot cover
2	Interior side

Splicing the Head Jamb

NOTE: You will have to splice your head jamb if the width of your door exceeds 21 feet (6.4 meters).

1. Spliced head jambs will be labeled to provide detail on where you need to install the various bundled components in [step 10 on page 16](#). A key is also provided for further detail on the component, track, and location.

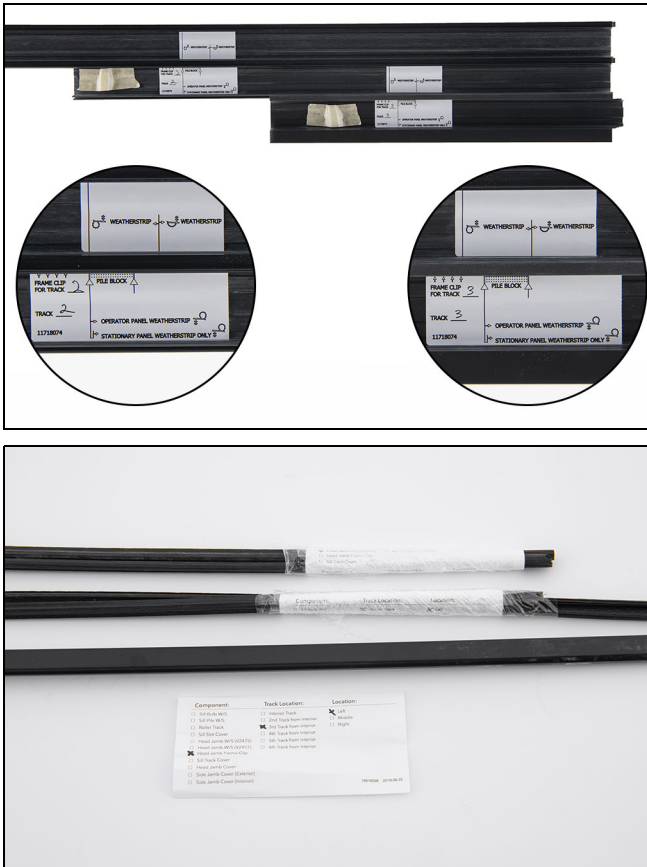

Figure 29

2. Lay the head jamb parts out on a flat clean and protected surface. [See Figure 30](#).

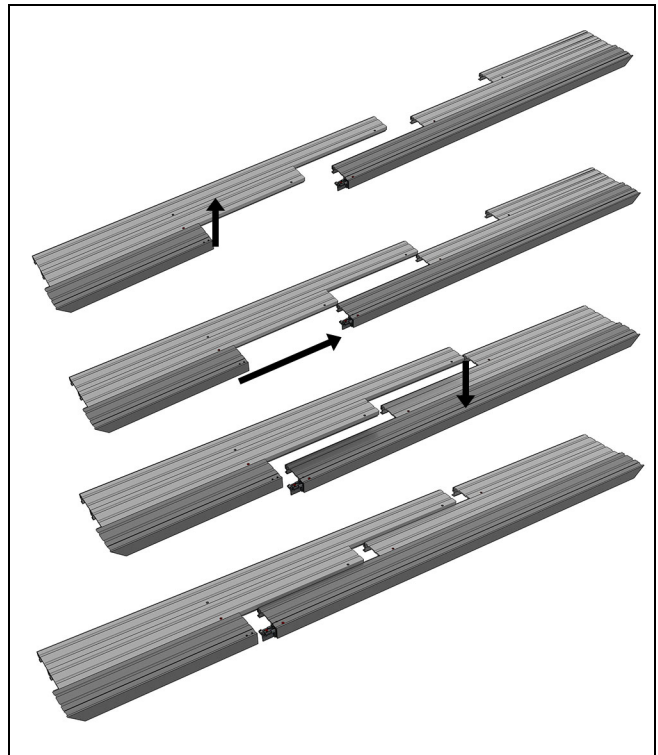

Figure 30

3. Press the splice sections together and seat with a rubber mallet. [See Figure 31](#).

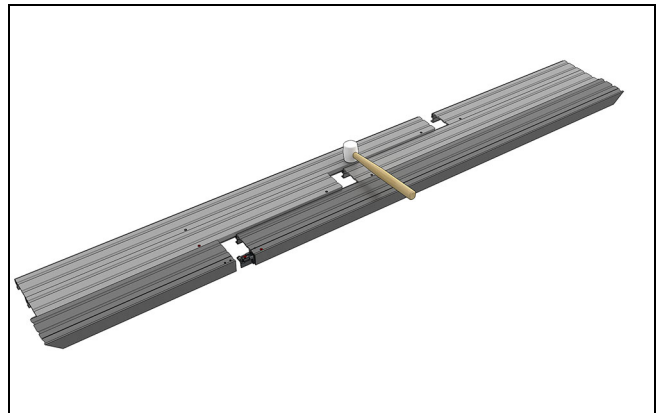

Figure 31

4. Remove the screws from the splice keys. [See Figure 32](#).

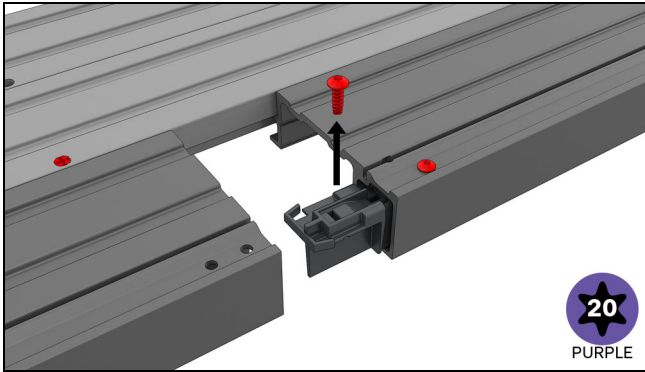

Figure 32

5. Press the splice sections together and seat with a rubber mallet. See Figure 33.

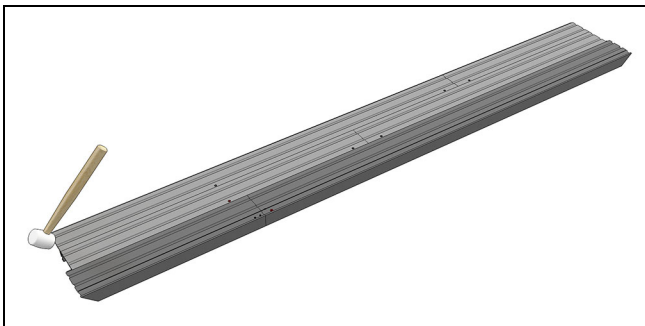

Figure 33

6. Fasten the head jamb splice key with #8 x 1/2" (13) screws. See Figure 34.

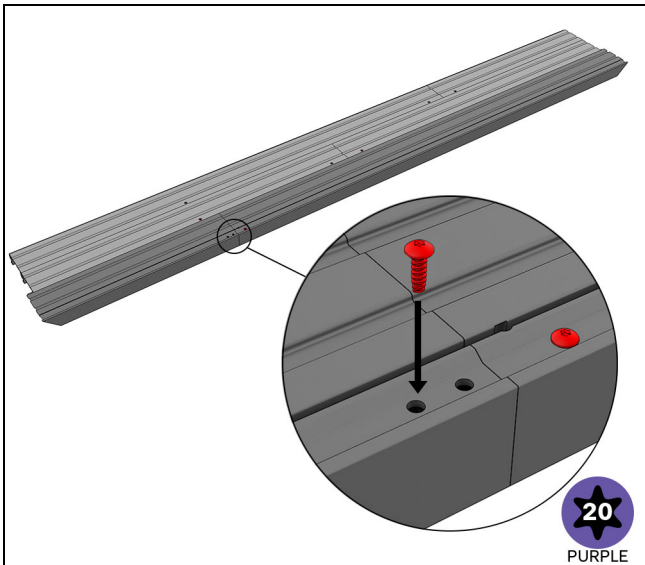

Figure 34

7. Inject sealant into the hole nearest the splice until squeeze out appears in the nearby relief hole in the nail fin kerf. See Figure 35.

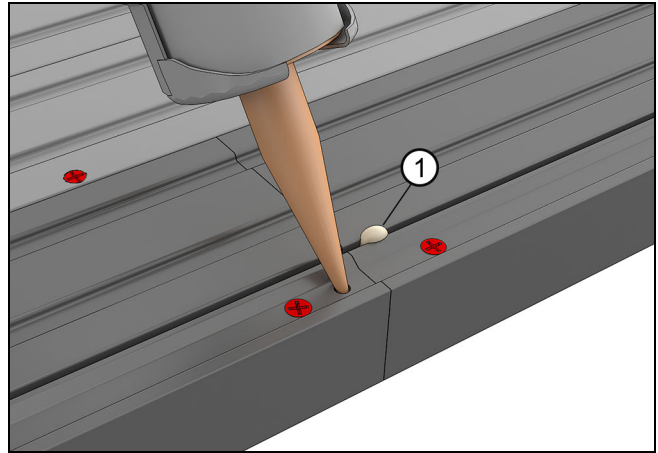

Figure 35

1	Sealant
---	---------

8. Drill pilot holes through the pre-drilled holes (found near the splice areas) using a 1/8" (3) Vix (self centering) drill bit. The depth cannot exceed 1/2" (13) deep. See Figure 36.

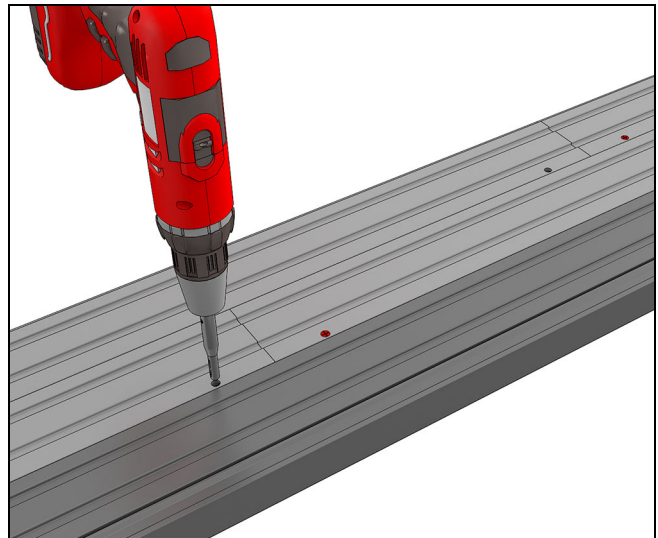

Figure 36

9. Insert #8 x 1/2" (13) screws and tighten. See Figure 37.

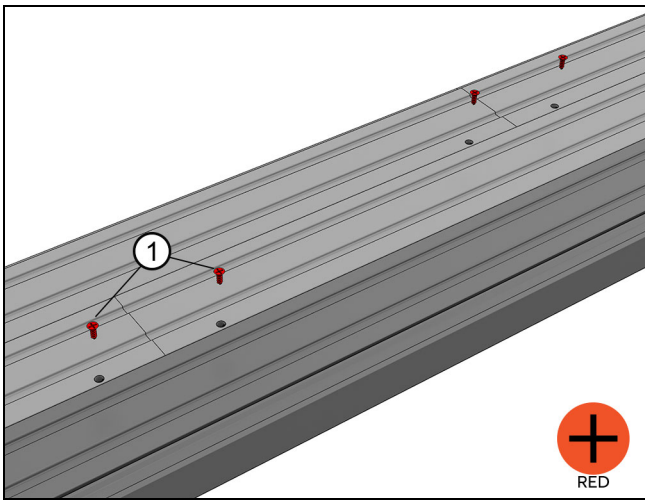

Figure 37

1	#8x 1/2" Phillips flat head screws
---	------------------------------------

10. Where required, add the frame liner, weather strip, dust blocks, and frame clips over the spliced sections. See Figure 38, Figure 39, Figure 40, and Figure 41.

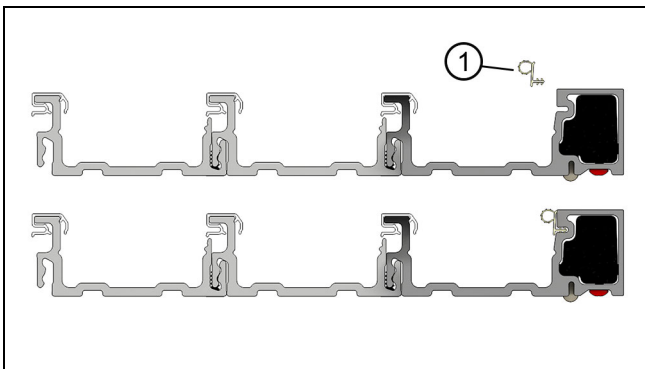

Figure 38

1	Head jamb weatherstrip
---	------------------------

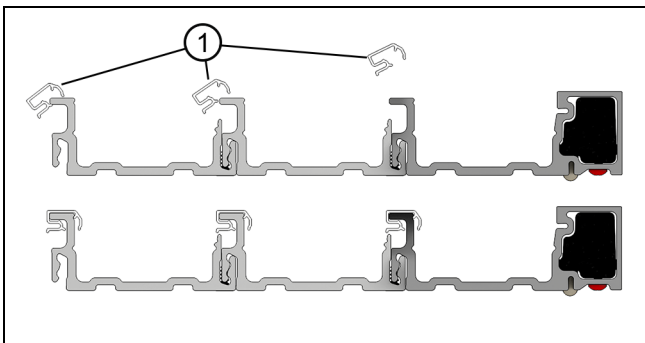

Figure 39

1	Frame clip
---	------------

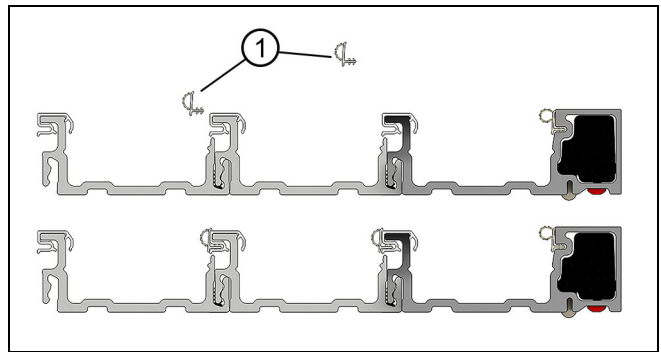

Figure 40

1	Frame weatherstrip
---	--------------------

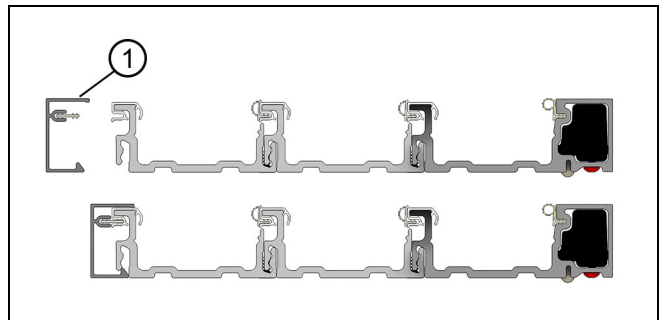

Figure 41

1	Head jamb liner
---	-----------------

11. Place dust block(s) on the frame clips approximately 7/8" (22) from the splice (on the stationary or pocket side). These will line up with the edge of the panels. See Figure 42.

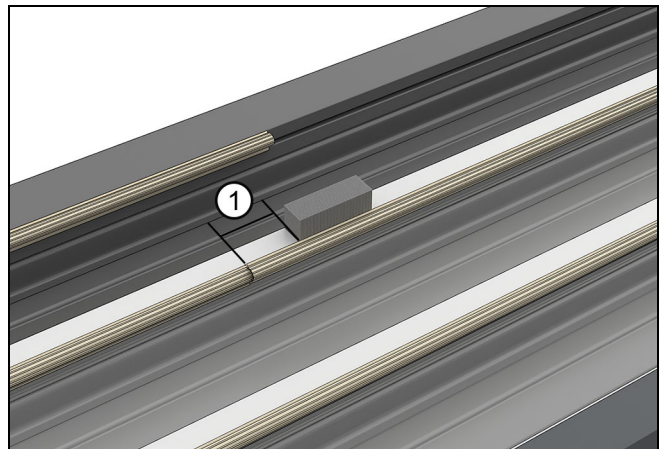

Figure 42

1	7/8" (22) from weatherstrip splice
---	------------------------------------

Assemble the Frame

Using a smartphone or similar device, scan the QR code below or click [here](#) to play a video of this procedure.



! CAUTION!

Wear gloves and protective clothing when handling the frame components. Some high-density fiberglass surfaces are not coated and can leave splinters in bare skin.

1. If your door is wider than 21 feet, you will need to splice your head jamb and sill components. Refer to [Splicing the Sill on page 10](#) and [Splicing the Head Jamb on page 14](#) before proceeding.

NOTE: Corner keys are pre-installed in the ends of the jambs at the factory.

2. Align the end of one side jamb with the head jamb and slide until the miter is flush. [See Figure 43](#)



Figure 43

1	Head jamb
2	Jamb

3. Slightly loosen the exterior screws holding the key to the jamb with a T20 Torx® head bit. This will allow the key to align with the head jamb holes. [See Figure 44.](#)

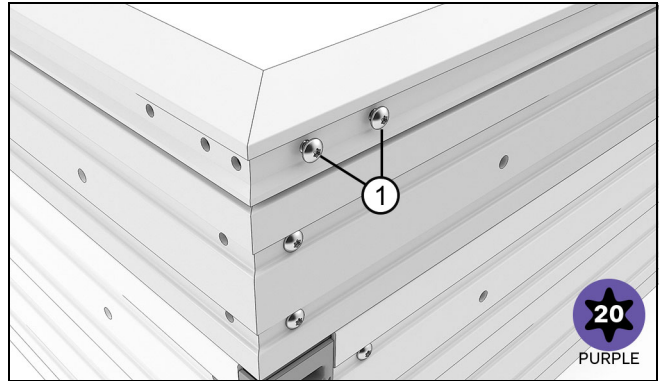

Figure 44

1	Loosen the exterior #8x 1/2" T20 screws holding key to jamb
---	---

4. Use the #8x 1/2" screws to fasten the head jamb to the key. [See Figure 45.](#)

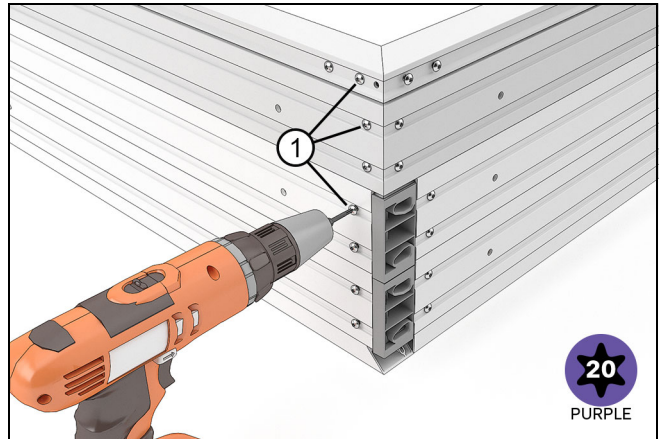

Figure 45

1	#8x1/2" T20 screws
---	--------------------

5. Tighten the jamb screws you loosened earlier. [See Figure 46](#)

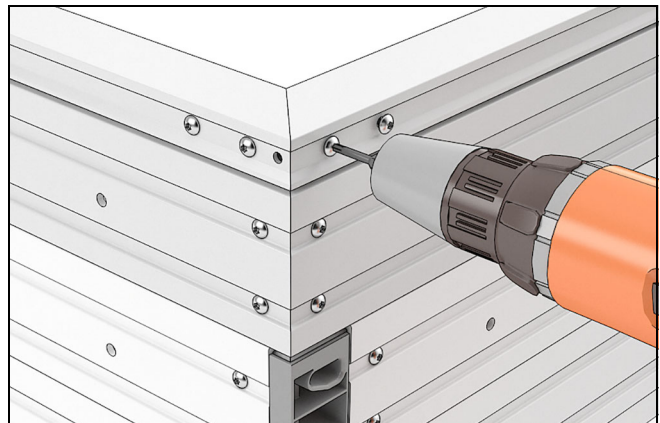

Figure 46

6. Assemble the other jamb to the head jamb assembly. See Figure 47.

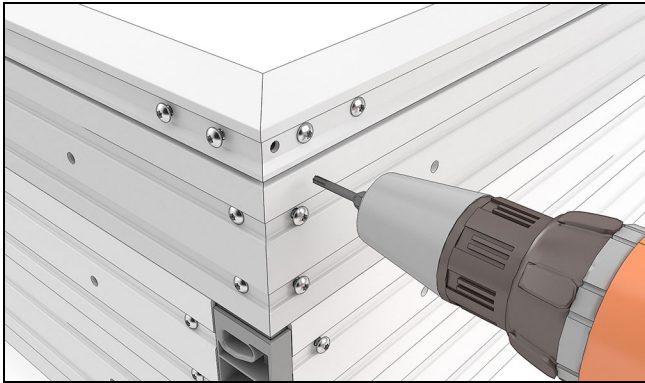

Figure 47

7. Slide the lower jamb corner keys into the sill. See Figure 48.

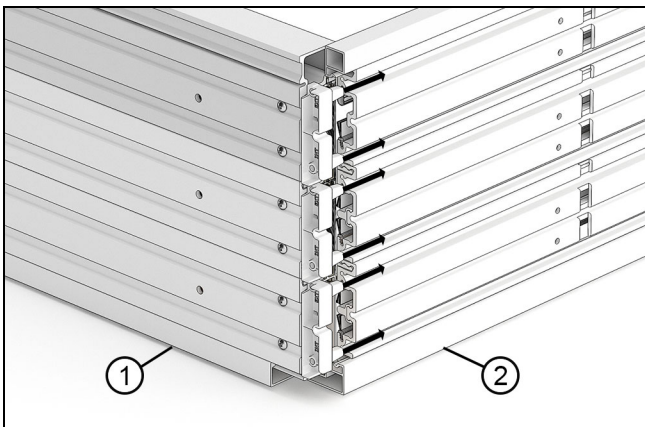

Figure 48

1	Jamb
2	Sill

8. Fasten with two #8x1 3/4" self drilling screws per key. See Figure 49.

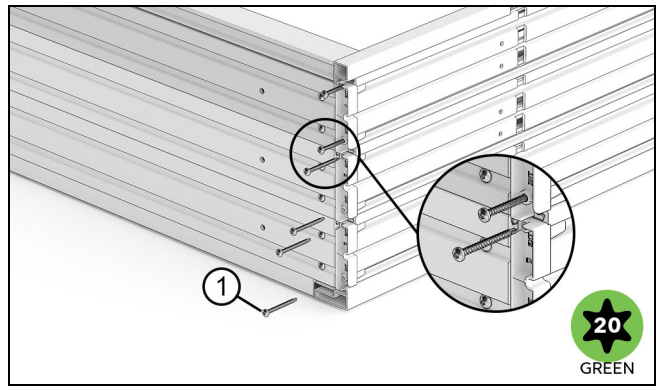

Figure 49

1	#8x1 3/4" self drilling screws (T20 Torx)
---	---

NOTE: Where applicable, peel away the last two inches of the nail fin from the head jamb to access the inspection holes.

9. Inject the head jamb corner keys until there is squeeze out showing in the inspection hole. See Figure 50.

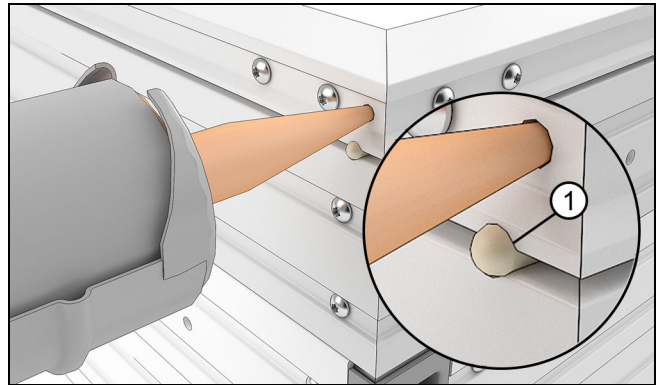

Figure 50

1	Sealant squeeze out from inspection hole
---	--

Install the Frame

Using a smartphone or similar device, scan the QR code below or click [here](#) to play a video of this procedure.



IMPORTANT

It is extremely important to start with a flat level sill. If you have not remedied an out of level sill, do so now.



Seek Assistance

You will need more than one person to install the frame.

1. Insert a "story pole" between the top of the sill and the head jamb track. Refer to field calculations for the proper length of story pole. See Figure 51.



Hint

Use crate material for the story pole.

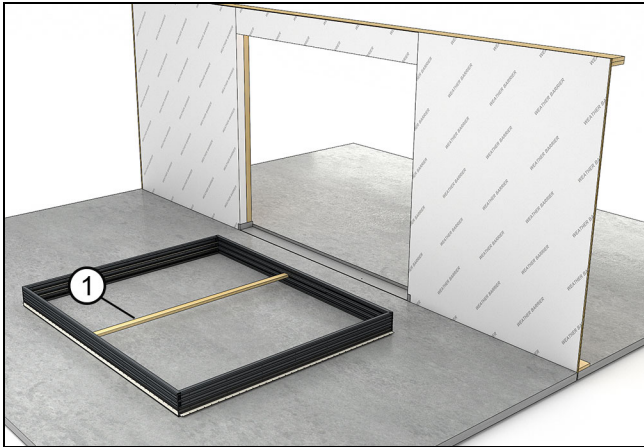

Figure 51

1	Story pole
---	------------

2. Stand the frame upright next to the rough opening and slide into the opening. See Figure 52.

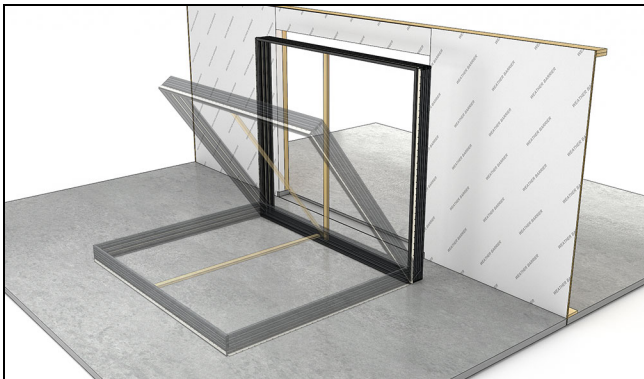

Figure 52

3. Verify that the sill is flat and level. Make adjustments as necessary. See Figure 53.



Figure 53

4. Use the chart below to determine proper fastener placement depending on configuration (number of tracks). See Figure 54.

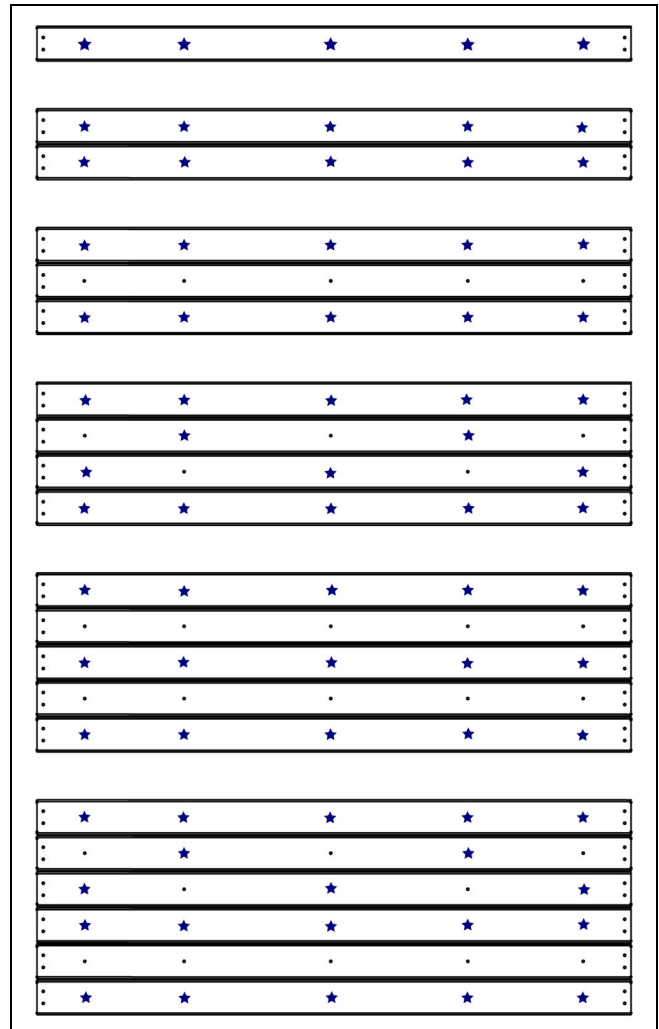

Figure 54 Place fasteners through Head Jamb, Sill, and Jamb at locations indicated by the star shapes above.

5. Center the frame in the rough opening and shim one corner at the bottom. See Figure 55.

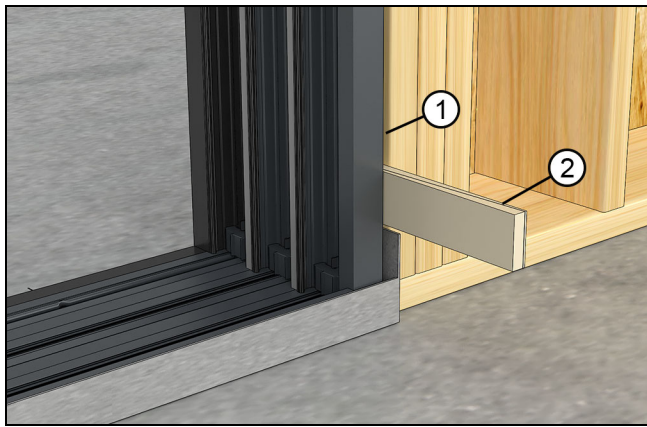

Figure 55 Center the frame and shim at stationary sill side

1	Center the frame in the opening
2	Shim stationary sill side

6. Position the frame to the correct depth inject sealant and install an anchor screw in the stationary side sill. See Figure 56.

NOTE: Depending on the substrate and fastener of choice, you may have to predrill before fastening. Follow all fastener manufacturer's recommendations.

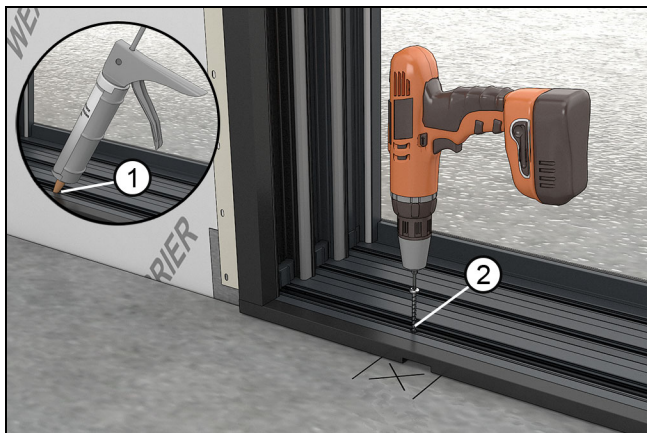

Figure 56 Fastening performance sill

1	Sealant
2	Fastener will vary depending on sill construction

7. If you have a performance sill or flush sill skip to [step 1 on page 21](#).

8. Position the frame to the correct depth and pre-drill into the HP sill near the stationary side. Drill through the

sill slope with a 1/8" drill bit. Then blow out the hole with compressed air. Do not puncture the optional pre-panning if used. See Figure 57.

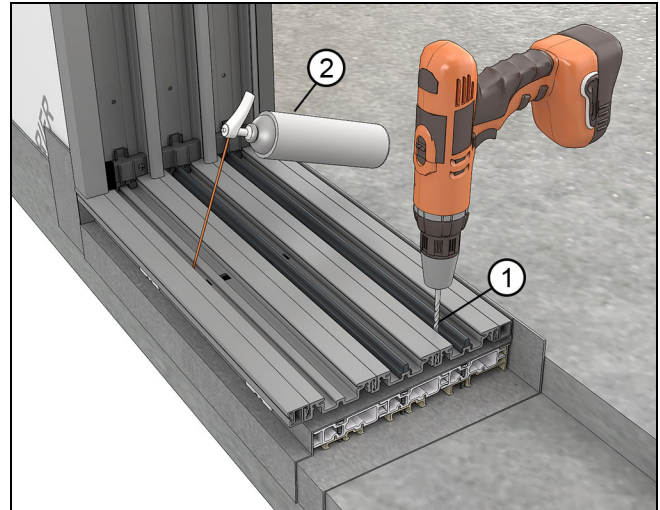

Figure 57 Drilling through HP stacked sill.

1	1/8" drill bit
2	Compressed air

9. Inject sealant and fasten with the #8 x 1 3/4" self drilling screws every 10" (254) (T20 Torx). See Figure 58.

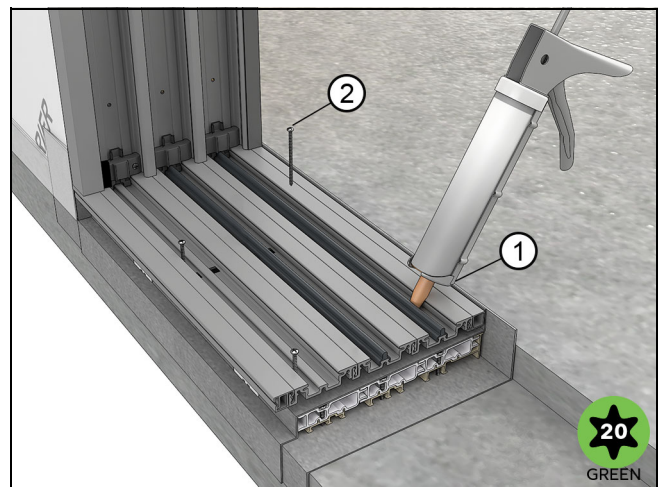

Figure 58 Seal and fasten HP sill.

1	Sealant
2	Screws

Squaring the Frame and Complete Fastening

Square the frame by starting with the stationary side top jamb, then move to the operating jamb, square and true the frame. Once the frame is square, plumb, and true in

the opening complete fastening all round. The following steps provide more detail.

1. Square the stationary side. Use a laser level and speed square to plumb the jamb. Move the jamb left to right until square. See Figure 59.



Figure 59

1	Laser line
2	Speed square

2. Apply shims and adjust, then fasten through the jamb stationary side near the top with a #10 x 3" (76) Torx (T20) screw provided. See Figure 60.



Figure 60

3. **Plumb and true the frame** so that it is aligned on the same plane. Move to the operator or opposite side and apply shims and adjust, then fasten through the operator (or opposite) jamb side near the top with a #10 x 3" (76) Torx (T20) screw provided. See Figure 61 and Figure 62.

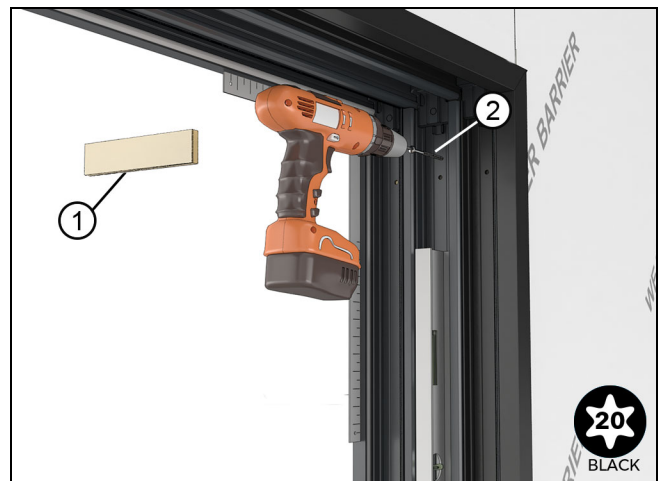

Figure 61

1	Shim
2	#10x3" flathead Torx screw (T20)



Figure 62 Make sure the entire frame is on the same plane and not twisted.



Hint

One way to plumb and true the frame is to attach crossing strings to the corners of the door diagonally. With the stationary side pinned in place, adjust the opposite side until the strings touch.

4. Starting at the center, shim and fasten the head jamb with #10 x 3" (76) screws so that a story pole stays in light contact with the sill and head jamb. Repeat this process the entire width. See Figure 63 and Figure 64.



Figure 63

1	Shim
---	------

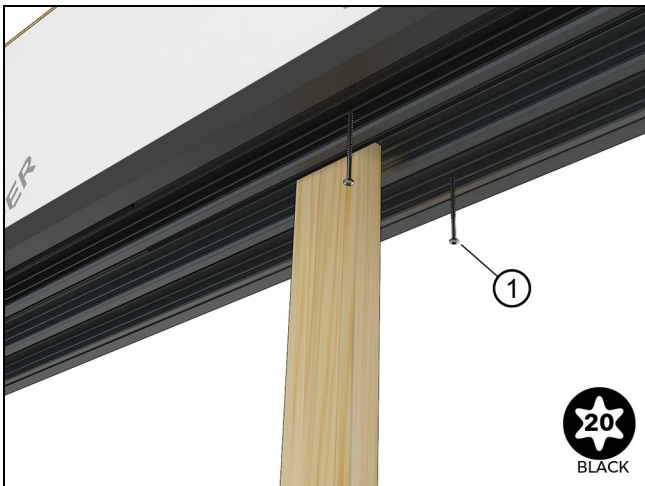

Figure 64

1	#10 x 3" installation screws
---	------------------------------

5. On bi-parting units, fasten the flush bolt strike through the pre-drilled holes near the center of the head jamb using #10x3" (64) screws. Make sure there is adequate shimming between the RO and the head jamb at the location of the strike. See Figure 65 and Figure 66.

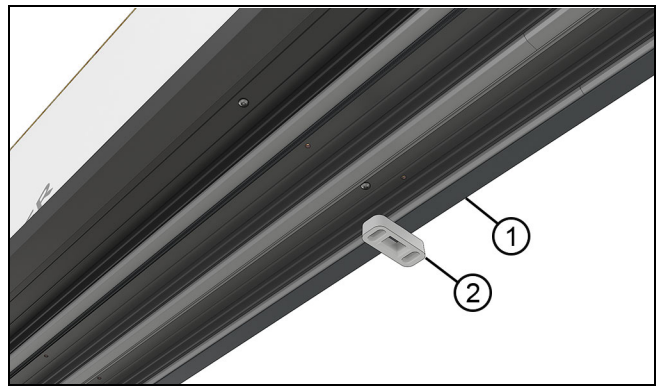

Figure 65

1	Interior
2	Flush bolt strike

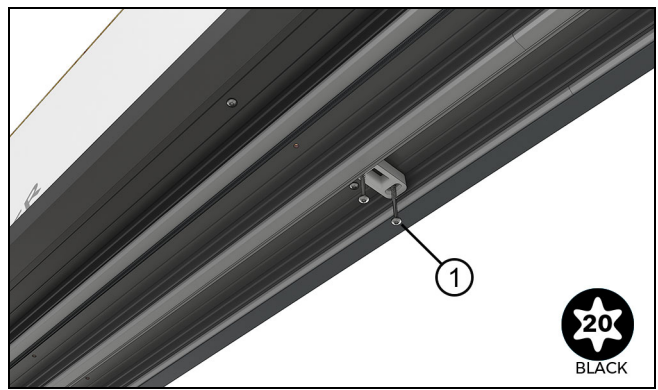

Figure 66

1	#10x3" Torx (T20)
---	-------------------

6. Install the remaining screws into the sill. (not provided on performance or flush sills). Fasten HP sills at 10" (254) on center. All other sills, fasten at 20" (508). See Figure 67. See Figure 54 previously for screw placement.

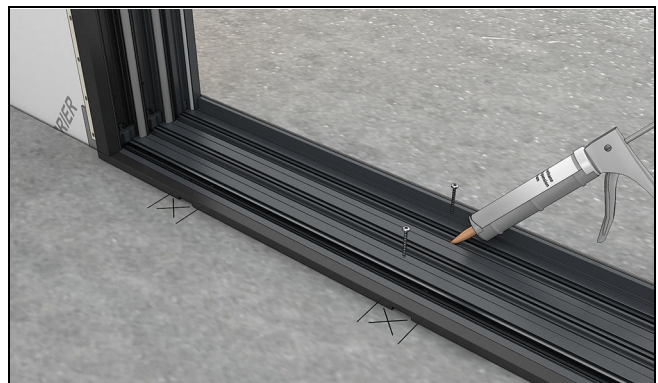

Figure 67

7. Complete fastening and shimming through additional fastener holes in the jamb. See Figure 68.

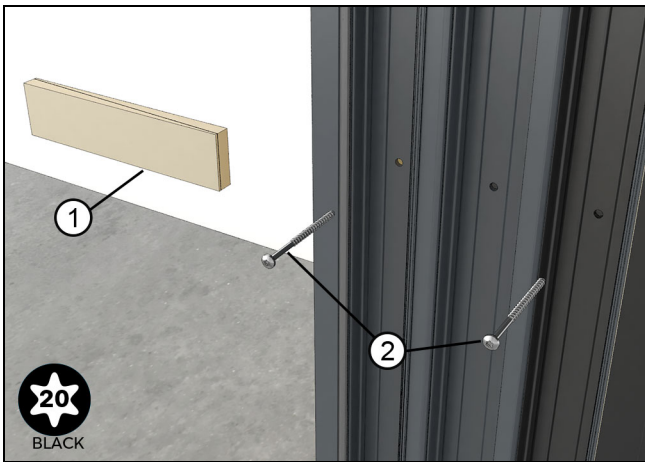

Figure 68

8. On uni-directional units, install the jamb filler with strike attached. The filler will snap into place, engaging with the top and bottom corner keys. See Figure 69.

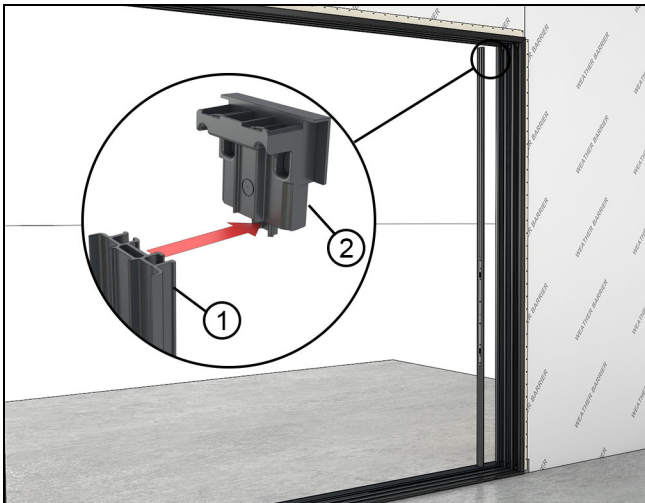

Figure 69

1	Jamb filler
2	Frame corner key (frame not shown in inset)

9. On uni-directional units, pre-drill through the open holes in the strike plate (above and below each strike) with a 3/16"(5) drill bit. See Figure 70.

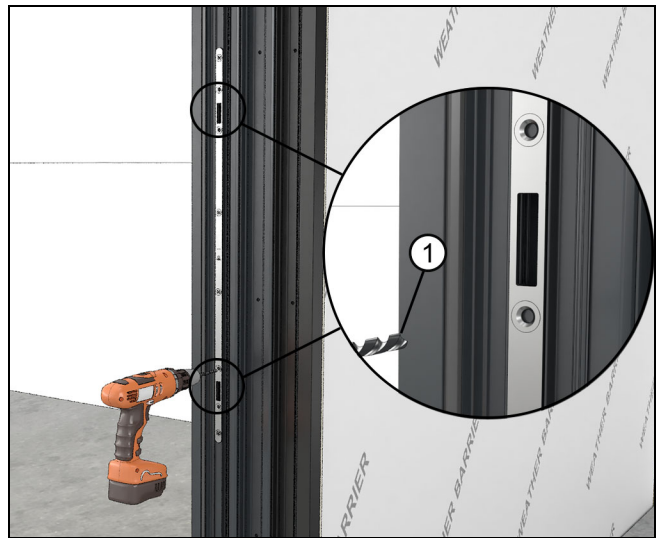

Figure 70

1	3/16" (5) drill bit
---	---------------------

10. Shim and fasten with #8x3"(76) screws provided. See Figure 71.



Figure 71

11. On uni-directional locking jambs, apply a dust block at the top of the interior track behind the bulb weather strip. Position the block so it is centered between the joint on the head jamb and jamb weather strips. See [Figure 72](#).

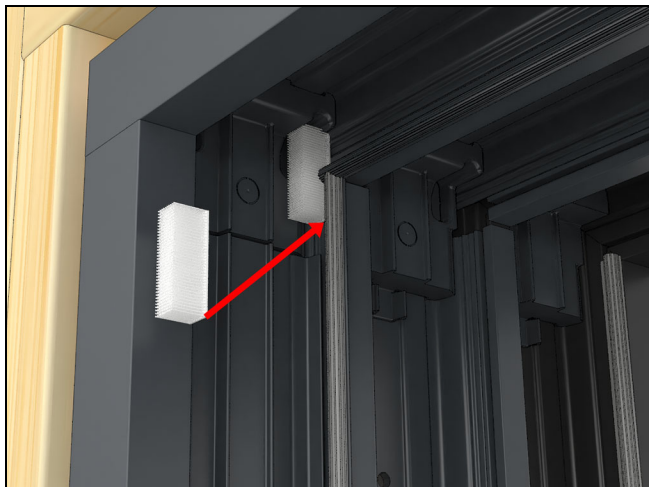

Figure 72

12. Place another dust block at the bottom of the jamb behind the jamb weather strip. See [Figure 73](#).

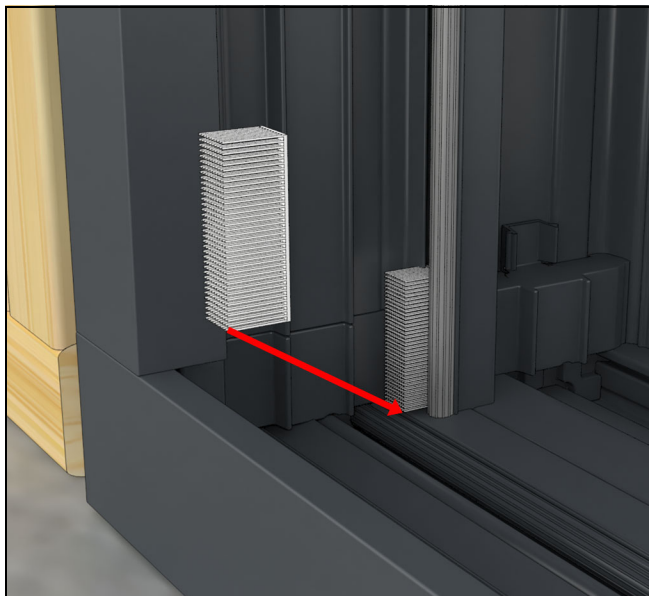

Figure 73

PANEL INSTALLATION

ATTENTION

Panels with Flush and High Performance sills can be installed from either the exterior or interior. Panels with Performance Sills can only be installed from the exterior. The following steps show an exterior installation. Reverse the panel order if you are installing from the interior.

WARNING!

LIFT HAZARD! Do NOT lift or move without proper equipment. Read, understand, and follow all lift equipment manufacturers' instructions and safety information.

Using a smartphone or similar device, scan the QR code below or click [here](#) to play a video of this procedure.



Order of Panel Installation

1. Organize and identify your panels.
2. Prep your stationary panels
3. Refer to the configuration specific sections for panel installation into the frame.
 - [Panel Installation-Standard Configurations on page 28](#)
 - [OX-O or O-XO Panel Installation on page 32](#)
 - [OOX, XOO, OOOX, and XOOO Panel Installation on page 37](#)
 - [OX-XOO or OOX-XO Panel Installation on page 42](#)
 - [XOX Panel Installation on page 47](#)
 - [XOOX Panel Installation on page 50](#)

Identifying Panels

1. Each panel is labeled with a letter that will help identify where it fits in the frame. You will find that information on a yellow label on the panel or packaging. Before you continue, its a good idea to note this letter designation somewhere easily seen on the panel. Use the table below and the following figures as reference to each panel location per configuration.

Letter	Description
A	Primary Operator
B	Secondary
C	Stationary
E	Inactive Operator
H	Stationary
J	Stationary
K	Stationary



Figure 74 Note: sticker may be in different location on panel.

1	Panel ID location on sticker
---	------------------------------

Stationary Panel Prep

Using a smartphone or similar device, scan the QR code below or click [here](#) to play a video of this procedure.



NOTE: Refer to [Figure 75 on page 27](#) for all steps in this section.

1. On stationary panels (C,J, K) place the upper stationary bracket over the interlock stile(s) and attach with a #8 x 1" (25) screw through the corner key. See [Figure 75](#) (1).

NOTE: (K) Stationary panels have interlocks at both stiles. Install a upper stationary bracket over both stiles.

2. On stationary (C, J, K) and secondary panels, fasten the cover retainer to the top and bottom of the stiles with a #8 x 1 3/4" (44) Phillips head screw. Slide the cover over the retainer. See [Figure 75](#) (2) and (4).

3. On stationary panels (C,J, K, H) place the lower stationary leveling block in the bottom rail channel. Align the wide part of the leveling block with the seam between corner key and the rail, then pre-drill with a 1/8" (3) drill bit. Fasten with a #8 x 1 1/2" (38) Phillips head screw. See [Figure 75](#) (3) and (5).

IMPORTANT

A tang may be present on the lower stationary leveling block. If you do not have a tang on your leveling block, an injected molded stationary bracket will be included in your Installation and Hardware Accessories Box and is used to keep the panel in place.

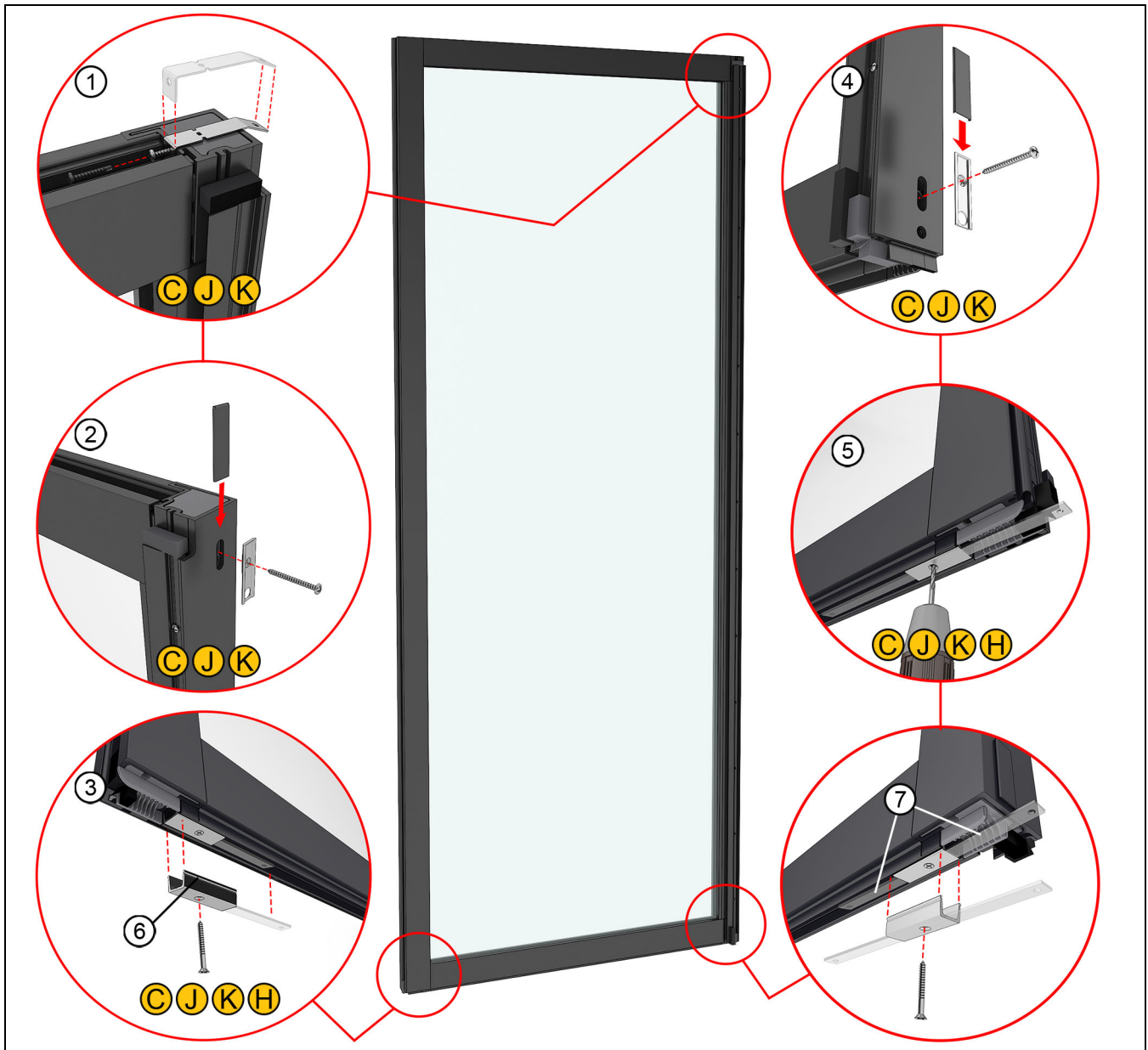

Figure 75

1	Install upper stationary brackets
2	Install cover retainer and cover at top of stile
3	Install leveling block in bottom rail channel
4	Install cover retainer and cover at bottom of stile
5	Install leveling block in bottom rail channel
6	On non-interlock stiles, the tang on the panel leveling block (if present) must be oriented toward the panel center
7	Interlock stiles are secured to the sill in one of two ways: an injected molded bracket; or a metal bracket with tang extending past the panel edge. If an injected molded bracket has been provided, the tang (if present) must be oriented toward the panel center.

Panel Installation-Standard Configurations

Standard configurations include: OX to OXXXXX, XO to OXXXXX, OX-XO to OXXXX-XXXXO.

ATTENTION

Panels with Flush and High Performance sills can be installed from either the exterior or interior. Panels with Performance Sills can only be installed from the exterior. The following steps show an exterior installation. Reverse the panel order if you are installing from the interior.



WARNING!

LIFT HAZARD! Do NOT lift or move without proper equipment. Read, understand, and follow all lift equipment manufacturers' instructions and safety information.

1. Install the primary operating panels or inactive panels first. Lift the top of the panel into the interior most head jamb track. Then swing the bottom over the sill track until centered over the roller guide. Set the panel gently onto the guide. [See Figure 76.](#)

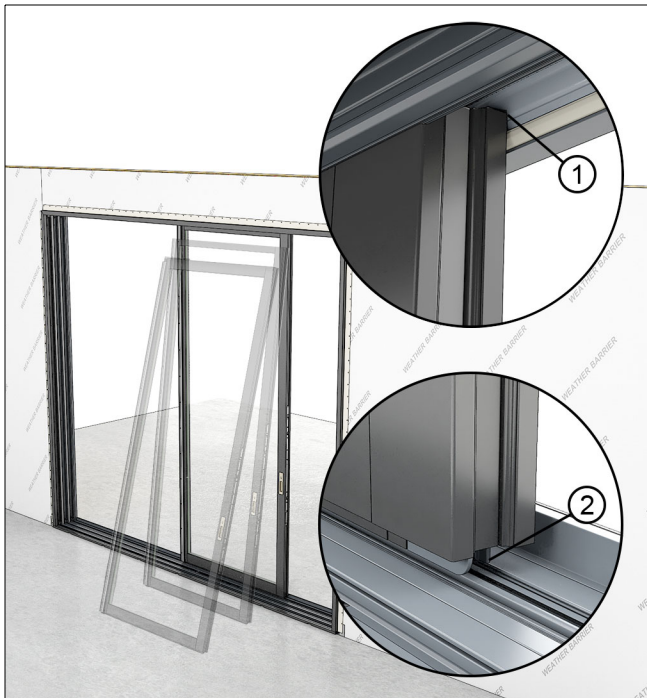

Figure 76

1	Lift the panel into the head jamb
2	Set the sill on the track

2. Install the secondary operating panels next. Make sure each panel overlaps the previously installed panel so that the interlocks can engage with one another. [See Figure 77.](#)



Figure 77

3. Install stationary panels last. Install the panel so it is as close to the jamb as possible but overlapping the previous panel installed. [See Figure 78.](#)

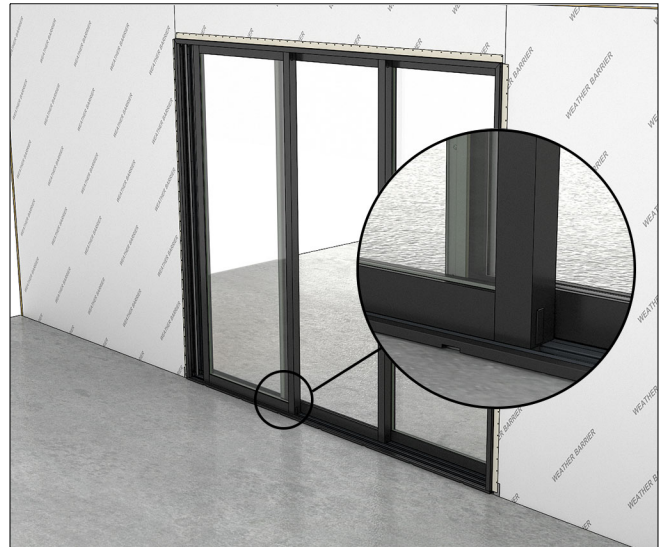

Figure 78

4. Slide the stationary panel tight against the stationary jamb. See Figure 79. Close and lock operating panels.

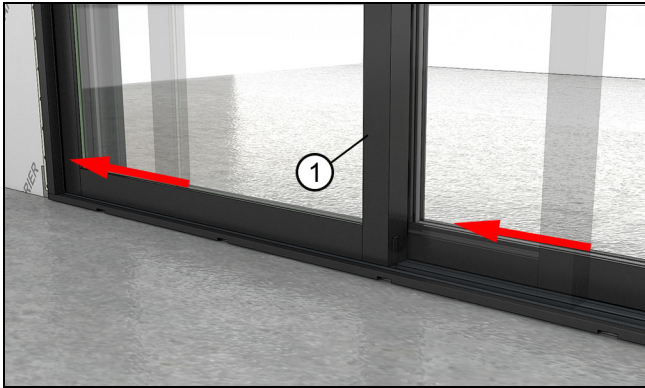

Figure 79 Move stationary panel tight against the jamb

IMPORTANT

Before proceeding make sure the stationary panel is centered on the track.

NOTE: See the section [Adjusting Panels on page 58](#) for details on adjusting rollers and panels.

5. Slide the stationary panel tight against the stationary jamb. See Figure 79. Close and lock operating panels.

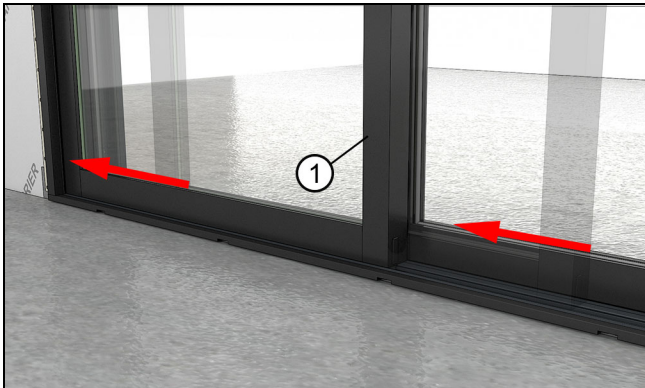

Figure 80 Move stationary panel tight against the jamb

IMPORTANT

Before proceeding make sure the stationary panel is centered on the track.

6. Measure from the edge of the stationary panel near the jamb. Move the meeting stile end of the stationary panel until the distance is the equal. See Figure 81 and Figure 82.

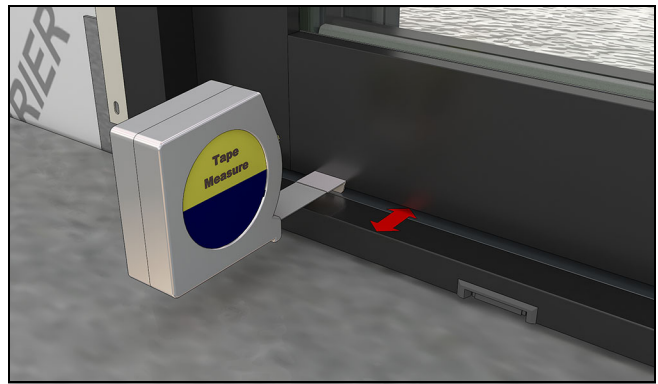

Figure 81

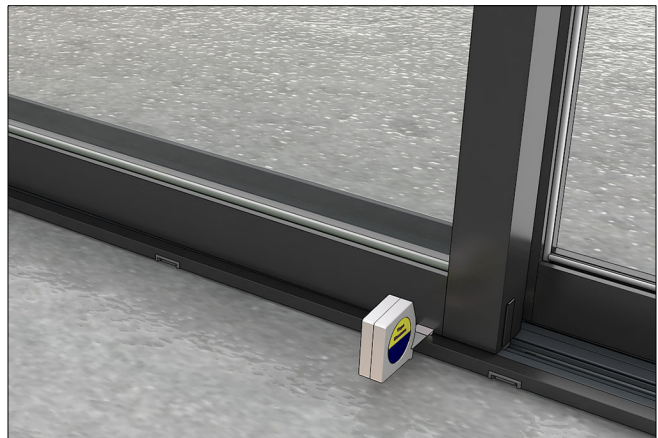

Figure 82

7. Install #8 x 7/16" Phillips self drilling screws through the bottom stationary bracket into the sill. See Figure 83

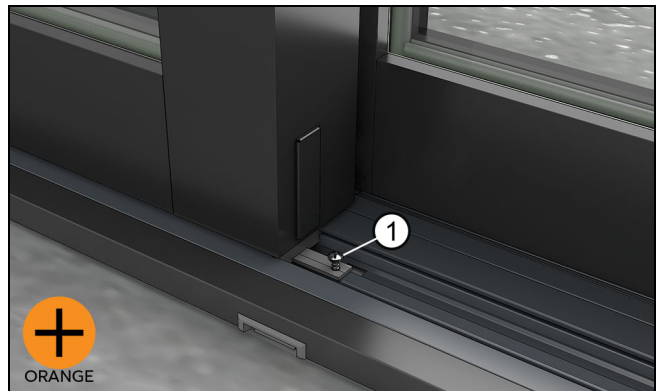

Figure 83

1	#8x7/16" Phillips
---	-------------------

8. Bend the top stationary bracket up against the head jamb and pre-drill a 3/16" (5) hole through the head jamb using the bracket as a template. See Figure 84 and Figure 85.

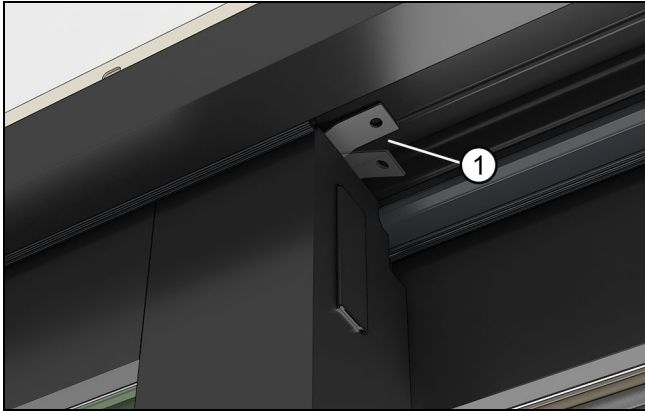

Figure 84

1	Head jamb stationary bracket
---	------------------------------

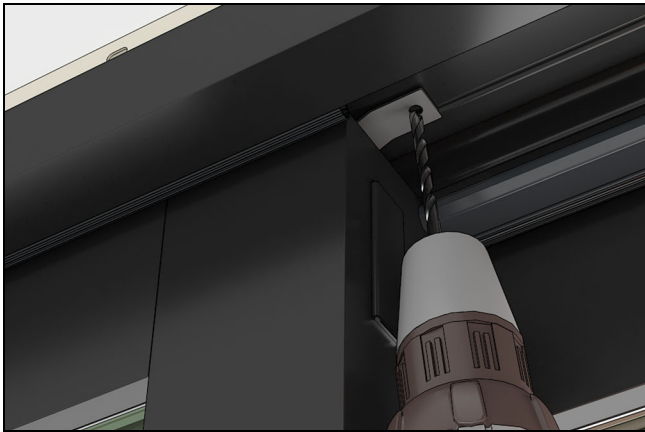

Figure 85

1	Head jamb stationary bracket
---	------------------------------

9. Fasten through the bracket into the head jamb framing with a #10 x 3" (76) installation screw. See Figure 86.



Figure 86

1	#10x3" Torx (T20)
---	-------------------

10. Test all the operating panels to make sure they lock and operate smoothly, adjust rollers if necessary.

11. On secondary panels, fasten panel bumpers to the interior meeting stile at the top and bottom with #10 x 1 1/2" Phillips head screws. See Figure 87.

NOTE: Bumpers with a "1" embossed in the back are used on secondary panels where they meet primary panels. Bumpers with a "2" embossed into the back of the bracket are used on secondary panels where they meet other secondary panels.

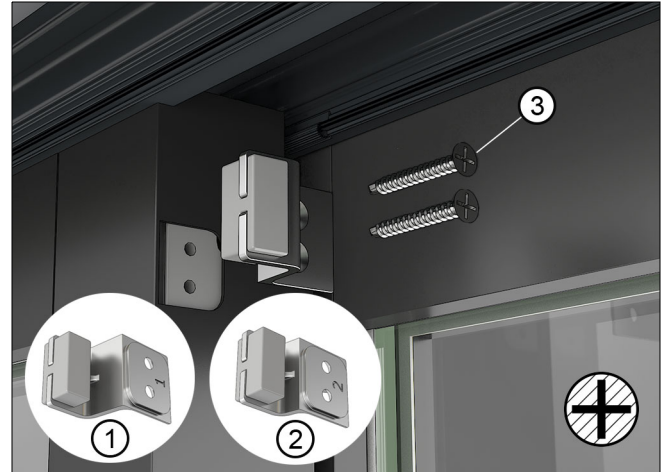

Figure 87 Top secondary panel bumper

1	Bumper used on secondary to primary
2	Bumper used on secondary to secondary
3	#10 x 1 1/2" Phillips head screw

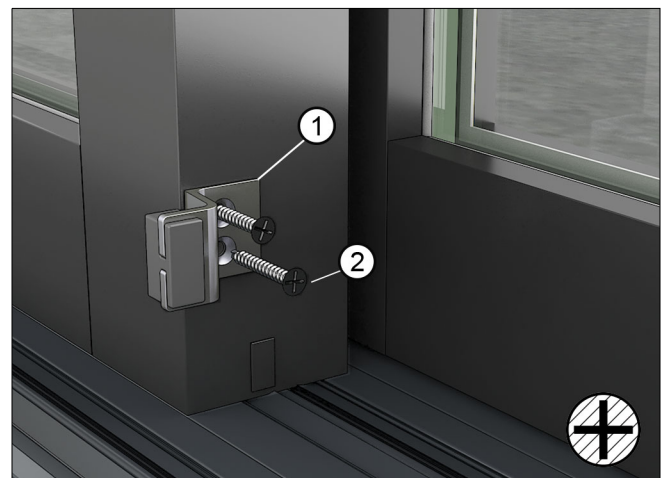

Figure 88 Bottom secondary panel bumper

1	Secondary panel bumper
2	#10 x 1 1/2" Phillips head screw

12. For stacked 2 track doors at the stationary jamb, insert the 1/8" (3) thick flex bumpers into the holes at the top and bottom of the interior jamb cover. Flex the bumper and insert into the holes. See [Figure 89](#) and [Figure 90](#).

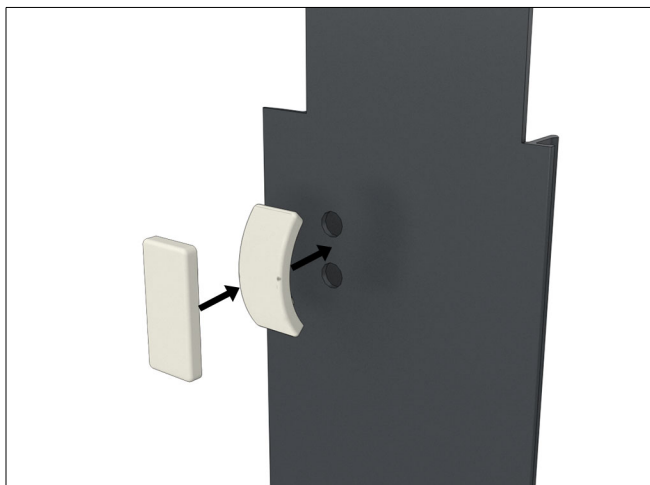

Figure 89 Flex the bumper and insert in top of jamb cover



Figure 90 Flex the bumper and insert in bottom of jamb cover

OX-O or O-XO Panel Installation

IMPORTANT

Doors with Automatic Control: Install the motor and drive belt prior to installing stationary panels.

NOTE: Illustrations in this section are shown from the exterior unless noted otherwise.

In general, three principles guide the order of installing each panel assuming you are installing the panels from the exterior:

- Start at the interior-most track and work your way to the exterior-most track.
- On each track, install operating panels first, then stationary panels next.
- On tracks that have only stationary panels, work your way over from the jamb.

NOTE: The "L" or "R" behind the letter designation signifies if the panel is on the left or right side of the walk-through opening as viewed from the exterior.

Use the following figure to further guide you on the order of panel installation.

- Install AR first
- Install HL second
- Install CR third

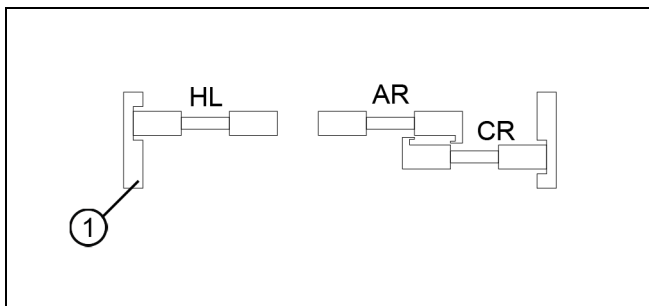

Figure 91 O-XO shown

1	Exterior side
---	---------------

1. Measure the (H) stationary panel OM. Transfer that measurement to the interior track of the head jamb and center the top stationary bracket at that distance. See Figure 92.

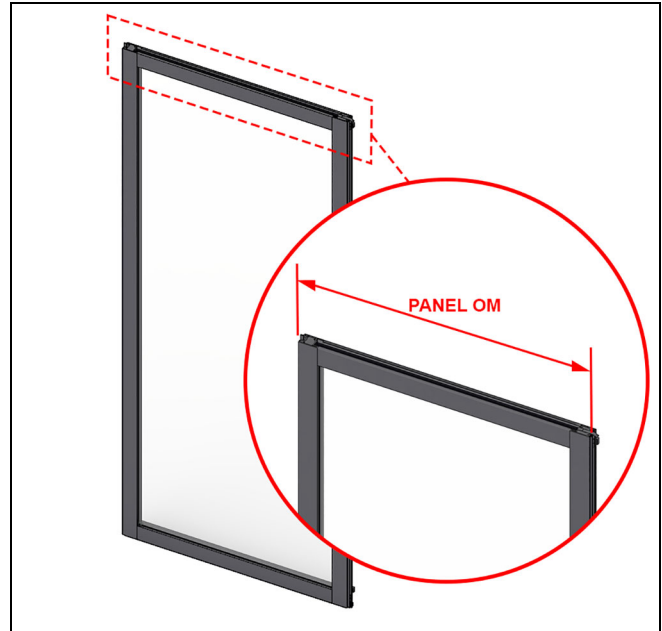

Figure 92

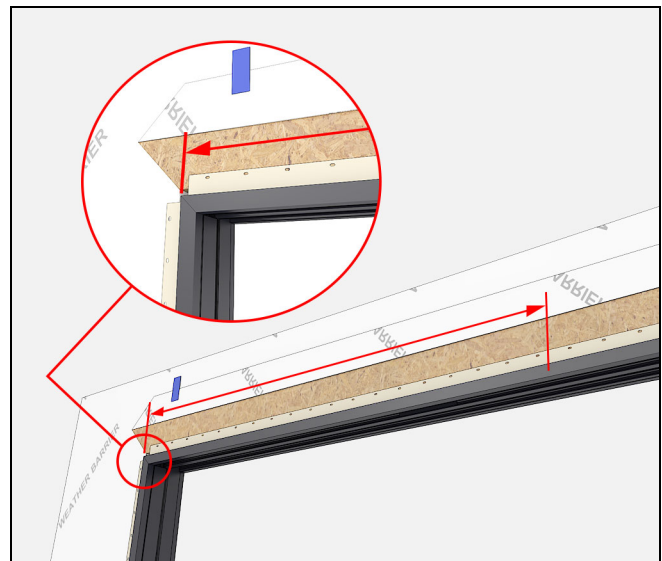

Figure 93

NOTE: If the bracket ends up on top of an installation screw, remove screw and shift the bracket left or right so that a hole in the bracket lines up with the installation hole. Reinstall previously removed screw.

2. Pre-drill a 3/16" hole through the head jamb using the bracket as a template. Pre-drill at each outside hole of the bracket, and at least once more in the middle of the bracket. See Figure 94.

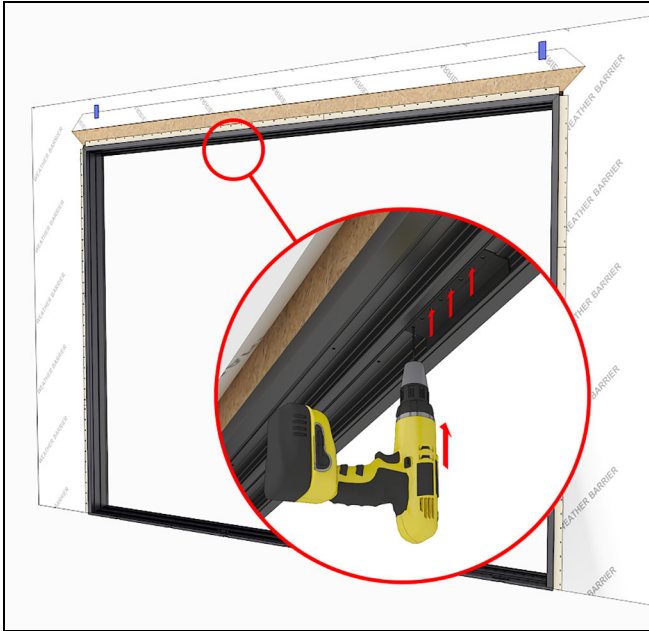

Figure 94

3. Fasten through the bracket into the head jamb framing with #10 x 3" installation screws at each pre-drilled location. Shim above the bracket as needed. See Figure 95.

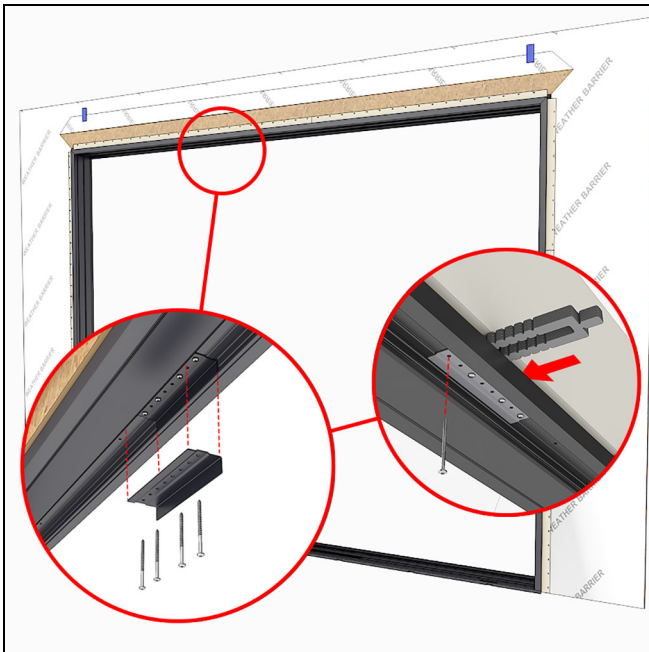

Figure 95

4. Install the operator panel (A) on the interior track. See Figure 96.

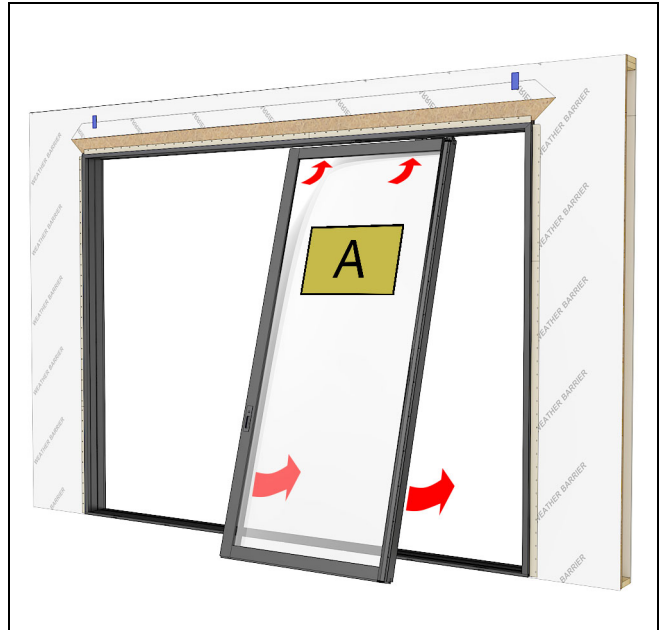

Figure 96

5. Install the first stationary panel (H) on interior track, slide panel tight against the stationary jamb. Measure from the jamb to the edge of the daylight opening. This should be about 2 5/8". See Figure 97 and Figure 98.

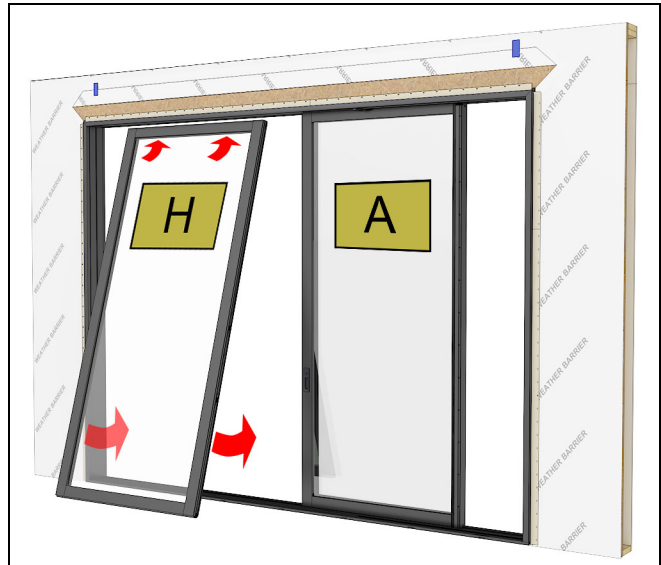

Figure 97

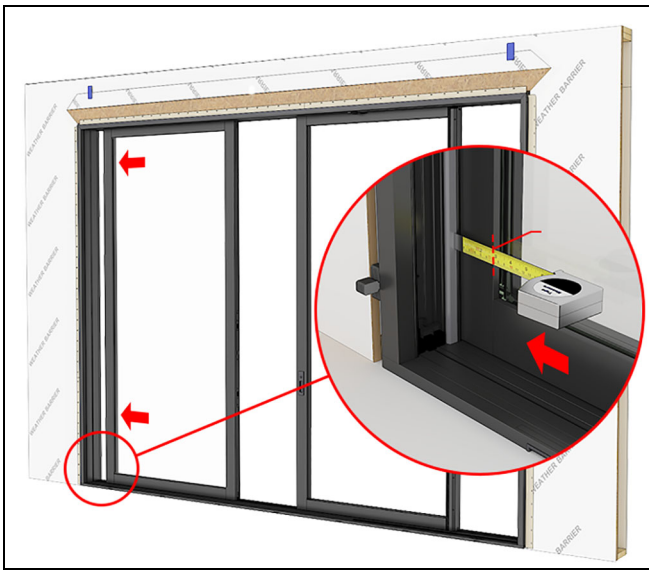

Figure 98

1	2 5/8"
---	--------

6. Snap the injection molded bottom stationary bracket in place and slide under the stationary panel. See Figure 99.

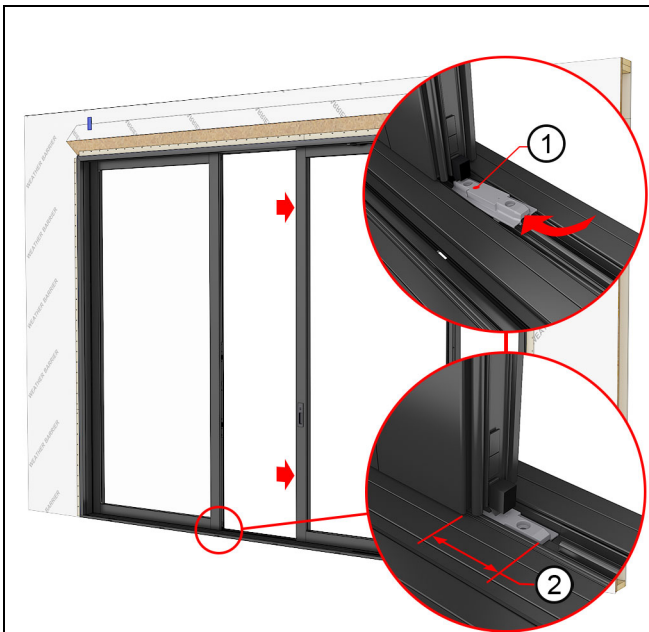

Figure 99

1	Bottom stationary bracket
2	2 1/4"

7. Close operator panel and lock. Adjust rollers as needed to achieve proper reveal and lockset engagement. See Figure 100. For more information on adjusting rollers, refer to the section, [Adjusting Panels](#) on page 58.

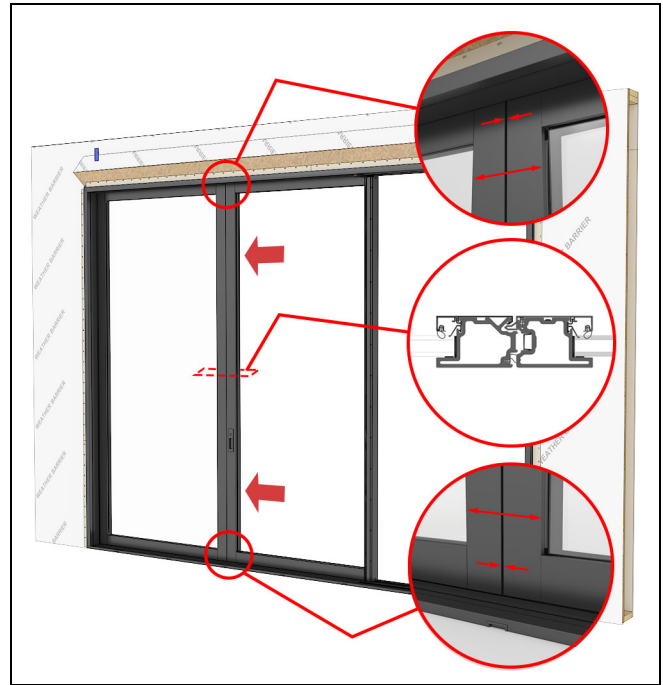

Figure 100 Adjust operator panel to obtain an even reveal.

8. Unlock and open the operator panel about 12"(305).

9. Install the second stationary panel (C) on the outside track, slide the panel tight against the jamb. See Figure 101 and Figure 102.

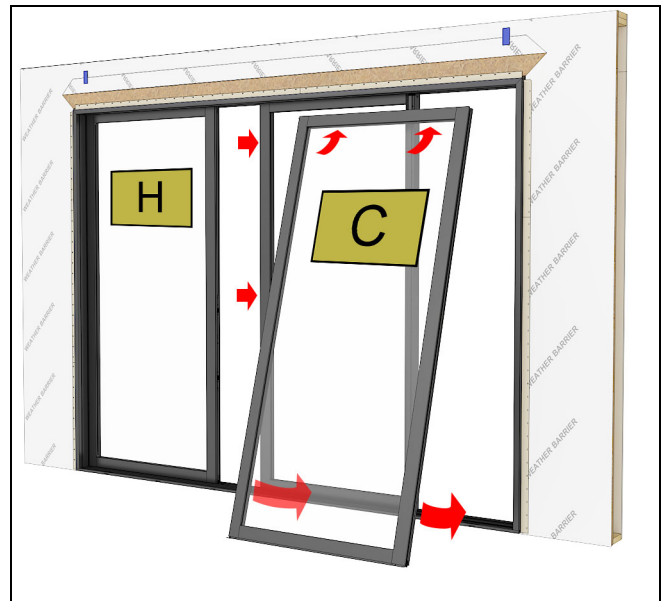

Figure 101

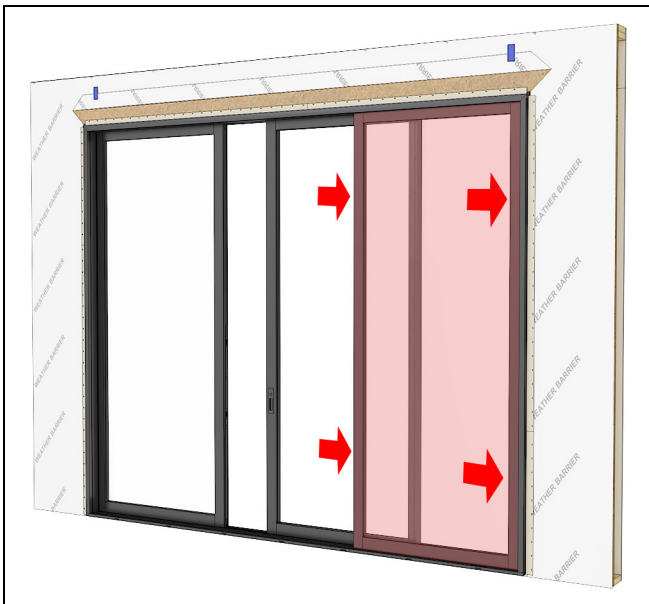

Figure 102

10. Close and lock the operator panel. Check to ensure proper interlock engagement and reveal. Adjust panel rollers as needed. See Figure 103.

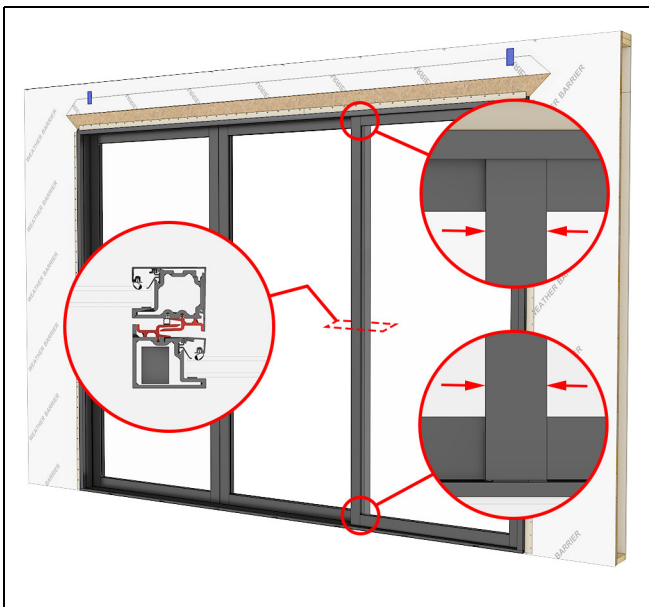

Figure 103

11. Measure from the jamb to the edge of the daylight opening. This should be about 2 5/8". See Figure 104.

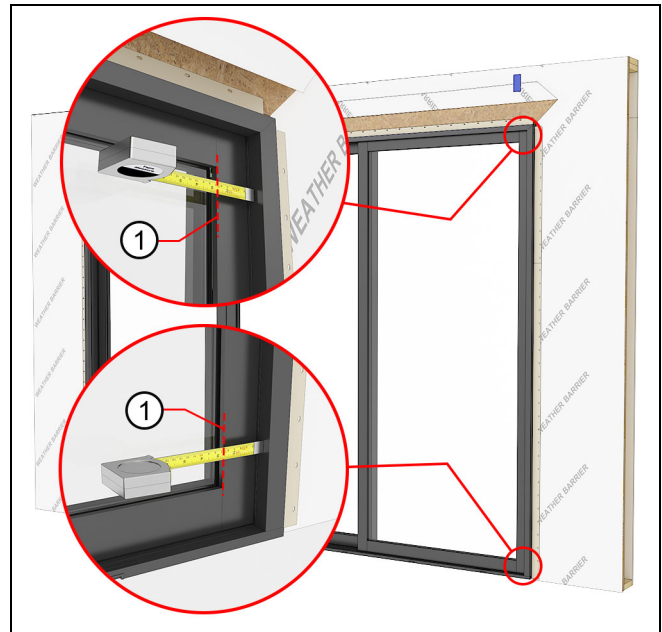

Figure 104

1	2 5/8" approximately. Reveal should be equal along jamb.
---	--

12. Secure the exterior (C) stationary panel with a #8 x 1/2" Phillips self-drilling screw through the bottom stationary bracket into the sill. Bend the top stationary bracket of exterior panel up against the head jamb, pre-drill a 3/16" hole through the head jamb using the bracket as a template. Fasten through the bracket into the head jamb framing with a #10 x 3" installation screw. See Figure 105.

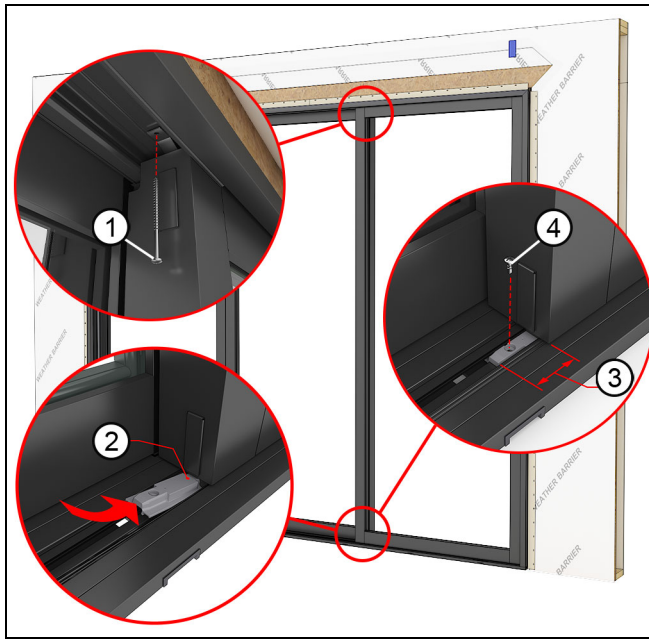

Figure 105

1	#10 x 3" installation screw
2	Bottom panel bracket
3	2 1/4"
4	#8 x 1/2" Phillips self drilling screw

13. Open the operator panel and fasten the first (H) stationary panel sill bracket. The bracket should stick out approximately 2 1/4" from the panel. See Figure 106.

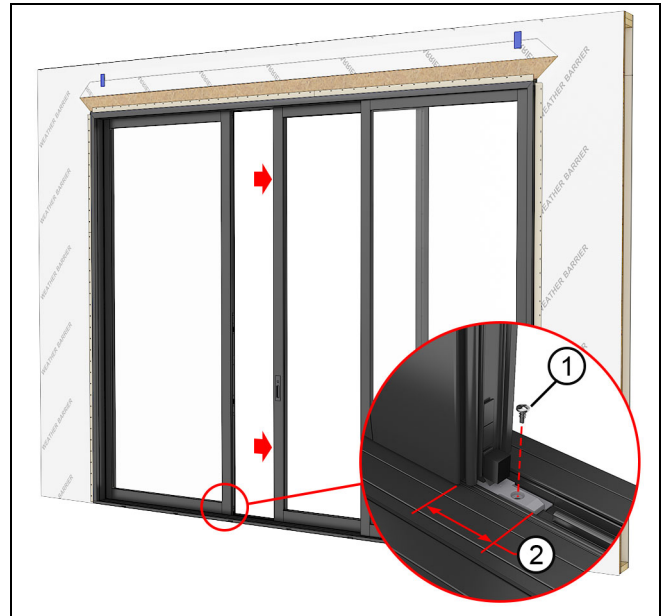

Figure 106

1	#8 x 1/2" Phillips self drilling screw
2	2 1/4"

OOX, XOO, OOOX, and XOOO Panel Installation

NOTE: Illustrations in this section are shown from the exterior unless noted otherwise.

In general, three principles guide the order of installing each panel assuming you are installing the panels from the exterior:

- Start at the interior-most track and work your way to the exterior-most track.
- On each track, install operating panels first, then stationary panels next.
- On tracks that have only stationary panels, work your way over from the jamb.

NOTE: The "L" or "R" behind the letter designation signifies if the panel is on the left or right side of the walk-through opening as viewed from the exterior.

Use the following figure to further guide you on the order of panel installation.

- Install A panel first
- Install H panel(s) next (two on OOOX or XOOO)
- Install C panel last

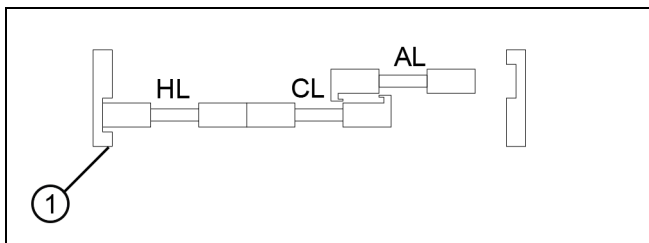

Figure 107 OOX shown

1	Exterior side
---	---------------

NOTE: On an OOOX configuration, the "H" panels will also be marked S1 and S2. XOOO configurations will be marked S3 and S4.

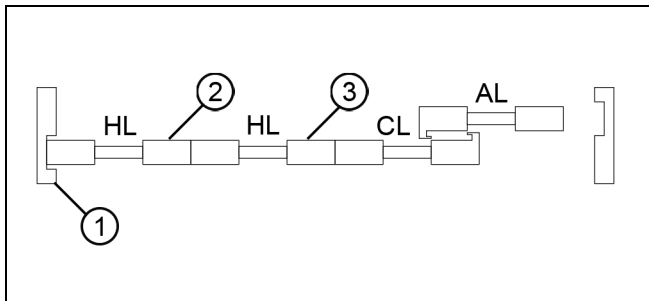

Figure 108 OOOX shown

1	Exterior side
2	S1 H Panel
3	S2 H Panel

1. Measure the (H) stationary panel OM. See Figure 109. Transfer that measurement to the exterior track of the head jamb and center the top stationary bracket at that distance. See Figure 110. On OOOX/XOOO, make a second mark from the first, using the same measurement. See Figure 111.

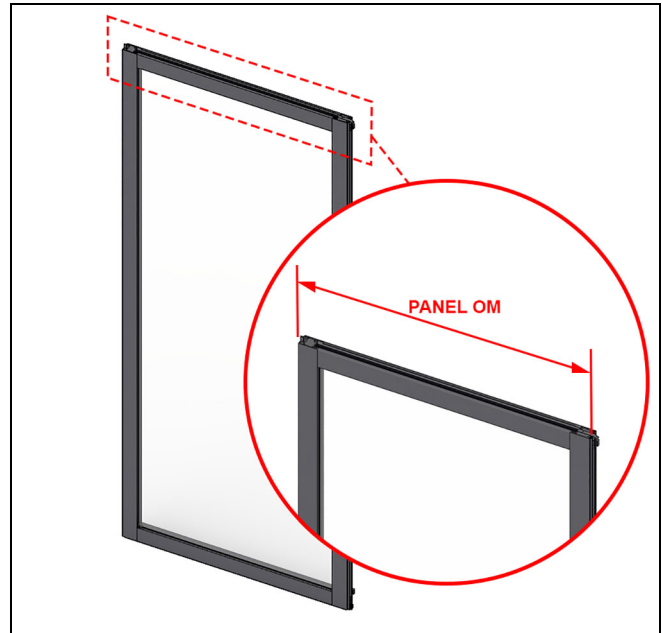

Figure 109

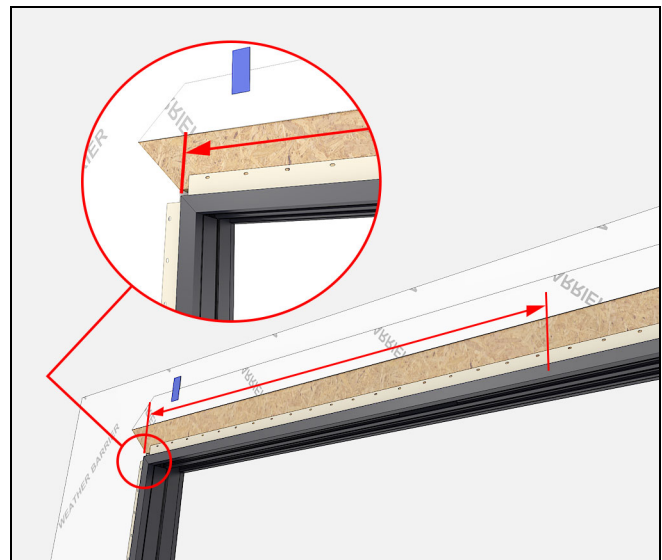

Figure 110 OOX shown

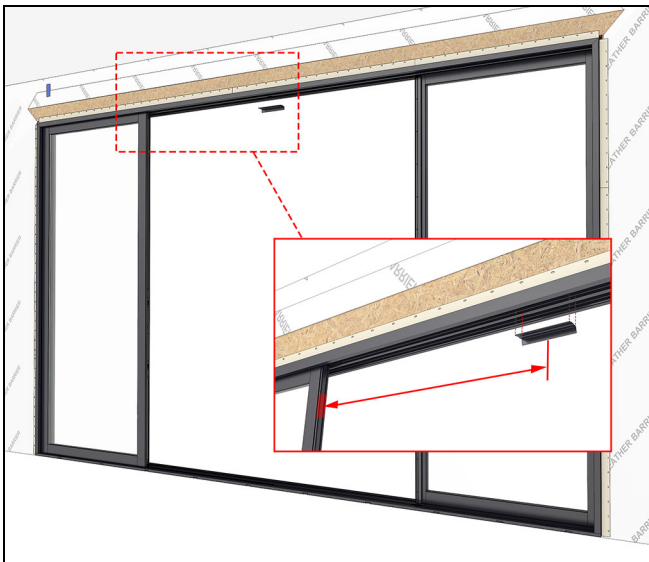

Figure 111 OOOX shown

NOTE: If the bracket ends up on top of an installation screw, remove screw and shift the bracket left or right so that a hole in the bracket lines up with the installation hole. Reinstall previously removed screw.

2. Pre-drill a 3/16" hole through the head jamb using the bracket as a template. Pre-drill at each outside hole of the bracket, and at least once more in the middle of the bracket. See Figure 112.

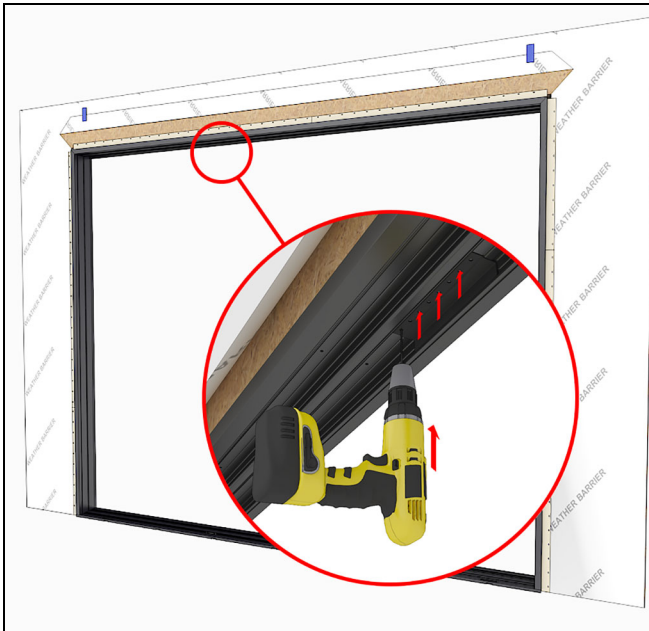

Figure 112

3. Fasten through the bracket into the head jamb framing with #10 x 3" installation screws at each pre-drilled location. Shim above the bracket as needed. See Figure 113.

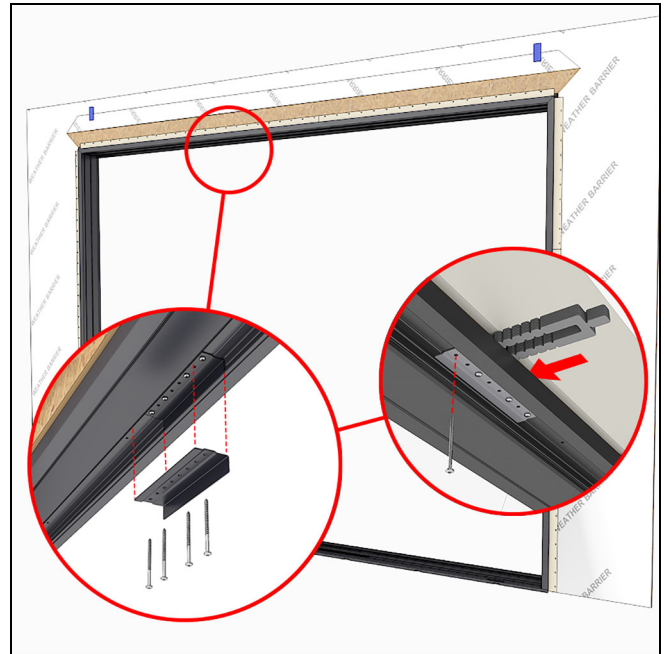

Figure 113

4. Install operator panel (A) onto the interior track. Lift the top of the panel into the interior most head jamb track. Then swing the bottom over the sill track until centered over the roller guide. Set the panel gently onto the guide. See Figure 114.

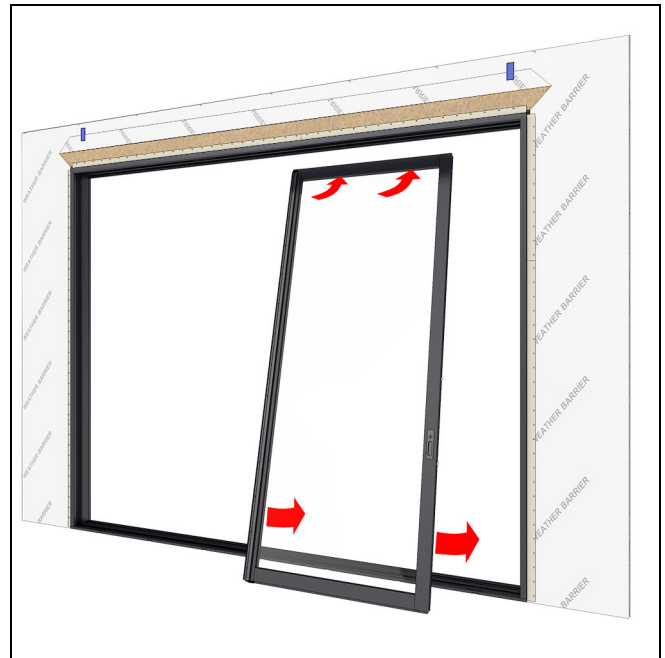

Figure 114

5. Close and lock the operator panel. See Figure 115.

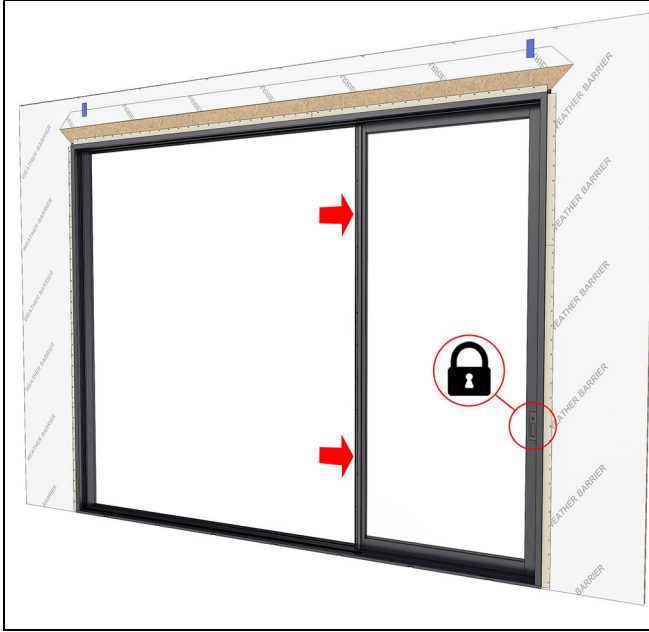

Figure 115

6. Install the (H) stationary panel (S1 H panel for OOOX, S4 H panel for XOOO) onto the exterior track, slide the panel tight against the stationary jamb. The measurement from the inside of the exterior frame to the edge of the daylight opening should be 2 5/8" (67) when the panel is fully seated inside the jamb. See Figure 116 and Figure 117.



Figure 116

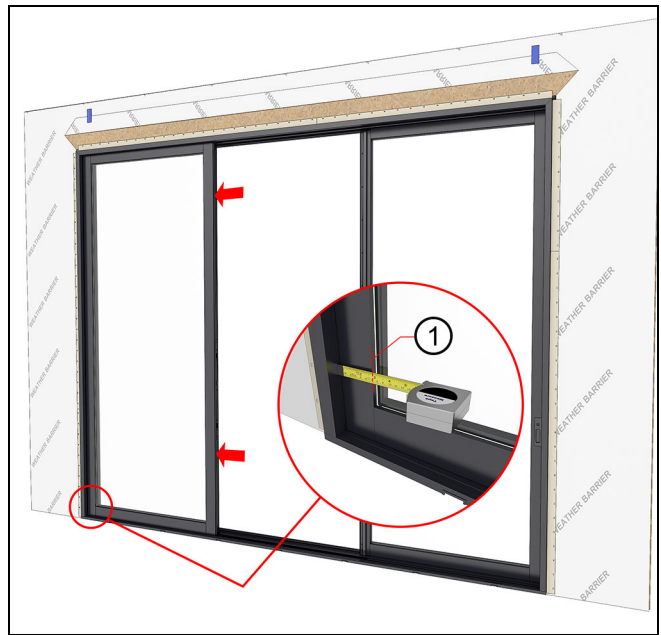

Figure 117

1	2 5/8"
---	--------

7. Snap the lower stationary bracket onto sill, then slide underneath the stationary panel until fully seated. The bracket should stick out approximately 2 1/4" (57) from panel when fully seated. Fasten with #8 x 1/2" screw. See Figure 118.

NOTE: When seated properly, one of the small dimples on the lower stationary bracket will be hidden.



Figure 118

1	Lower stationary bracket
2	2 1/4"
3	#8 x 1/2" self drilling screw

8. Install the next (H) stationary panel. Slide the panel tight against the previous panel. See Figure 119.

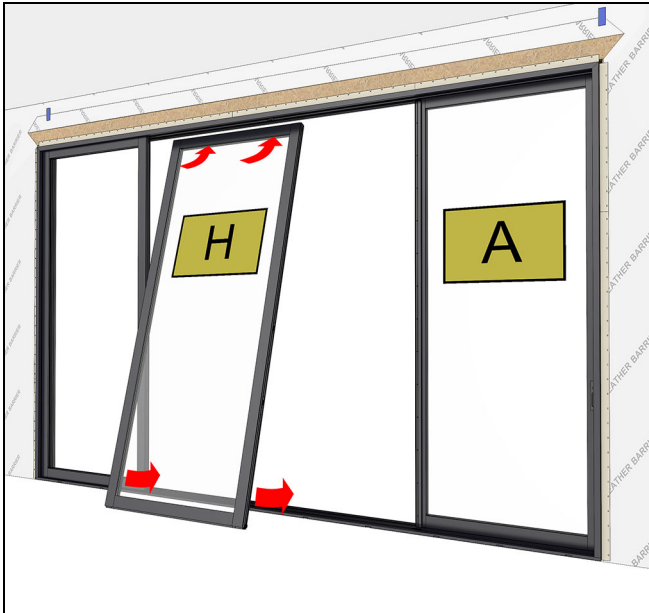

Figure 119 OOOX configuration shown.

9. Snap the lower stationary bracket onto sill, then slide underneath the stationary panel until fully seated. The bracket should stick out approximately 2 1/4" (57) from panel when fully seated. Fasten with a #8 x 1/2" self drilling screw. See Figure 120.

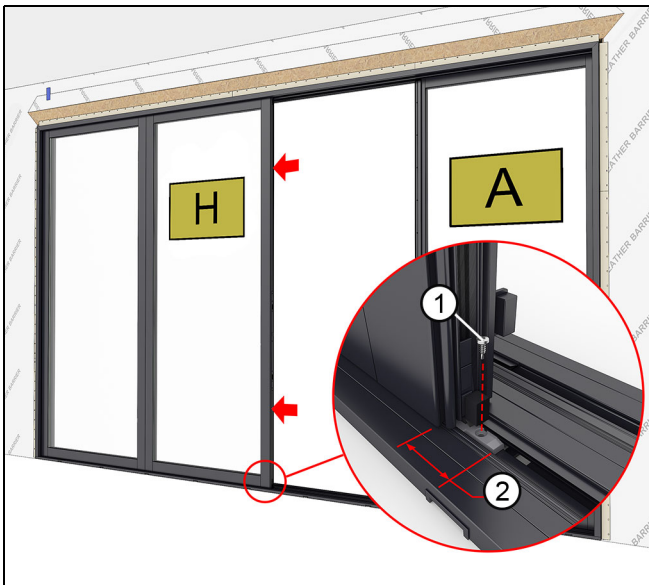

Figure 120 OOOX shown

1	#8 x 1/2" self drilling screw
2	2 1/4"

10. Unlock and open the operator panel about 12"(305).

11. Install the (C) stationary panel, making sure the panel overlaps the operator panel. See Figure 121.

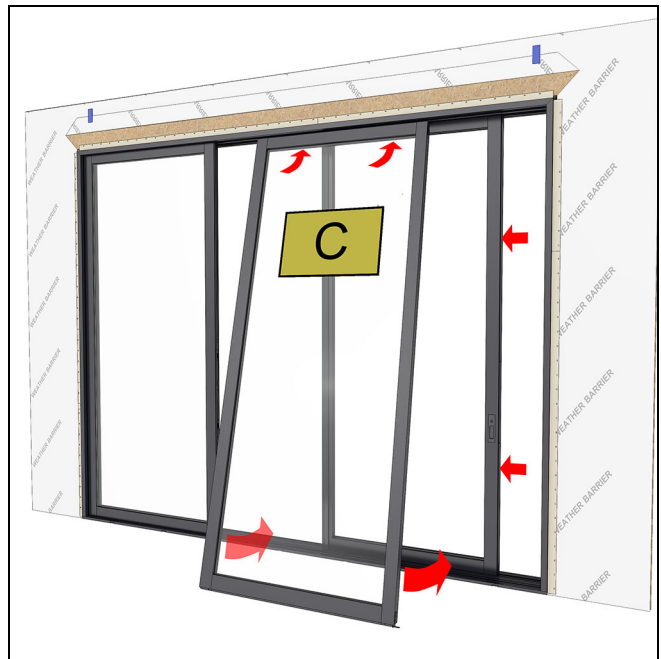

Figure 121 OOX configuration shown.

12. Slide the (C) panel over tight against the (H) stationary panel. Check to make sure you have an even reveal along the panel. The gap should be about 1/4" or less. See Figure 122.

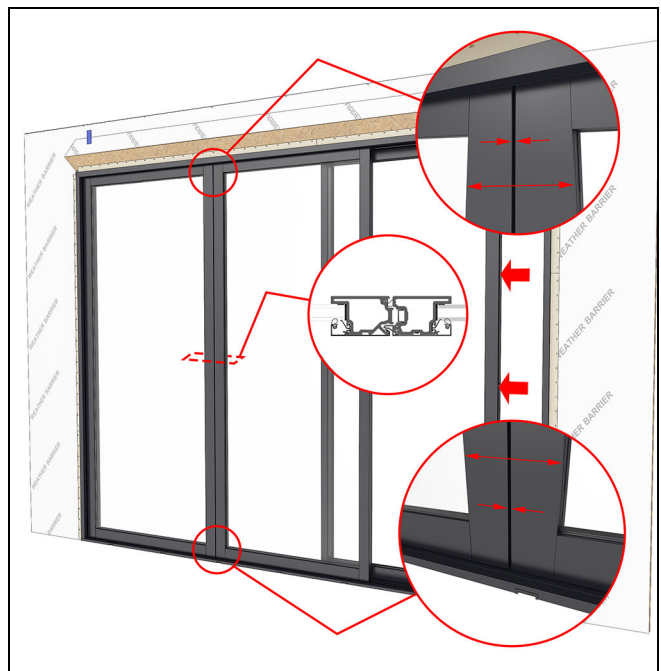

Figure 122

13. Snap the lower stationary bracket onto sill, slide underneath the panel until fully seated. Bracket should stick out approximately 2 1/4" from the panel when fully seated. Secure with a #8 x 1/2" Phillips self-drilling screw through the bottom stationary bracket into the sill. See Figure 123 (2, 3, and 4).

14. Bend top stationary bracket of (C) stationary panel up against the head jamb, pre-drill a 3/16" hole through the head jamb using the bracket as a template. Fasten through the bracket into the head jamb framing with a #10 x 3" installation screw. Shim as needed taking care not to bow the head jamb. See Figure 123 (1).

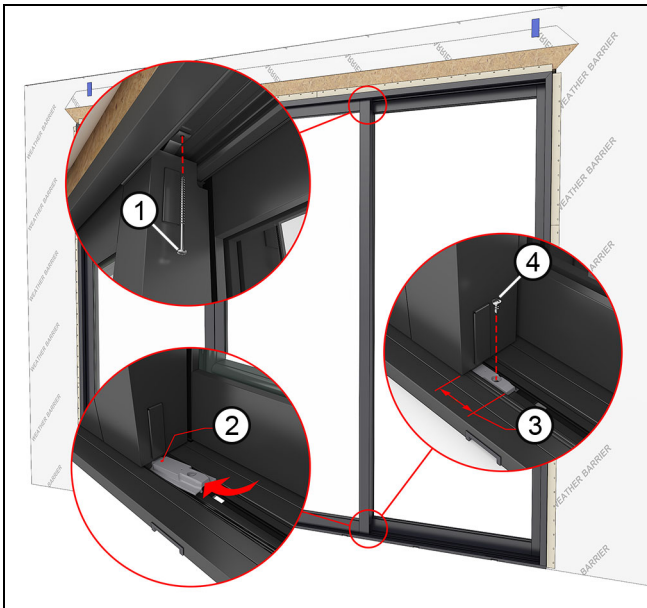

Figure 123

1	#10 x 3" installation screw
2	Lower stationary bracket
3	2 1/4"
4	#8 x 1/2" Phillips self drilling screw

15. Check the operator panel for an even reveal. Adjust panel rollers as needed for proper lock engagement and reveal. See Figure 124.

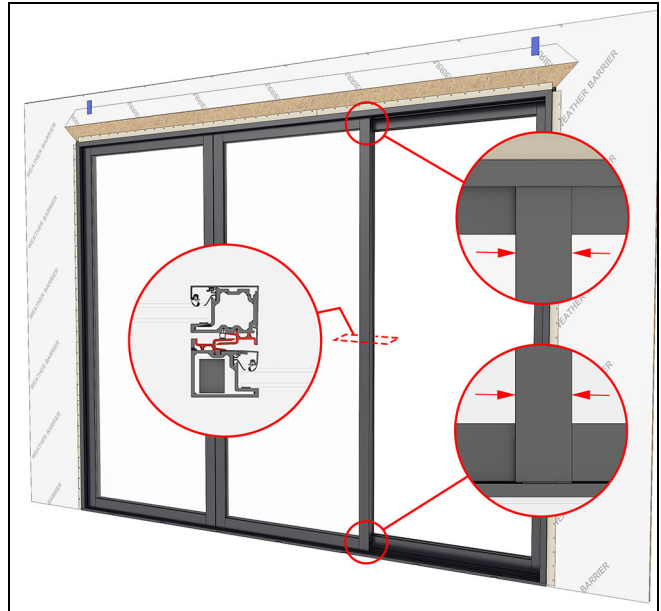

Figure 124

16. Install the bumper brackets on the (H) panel adjacent to the (C) panel at the top and bottom of the stile. Orient the bracket so the tab is pointed at the operator panel. Install with #10 x 1 1/2" Phillips head screws. Insert the bumper on the bracket so the thicker part of the rubber is pointed at the operator panel. See Figure 125.



Figure 125

OX-XOO or OOX-XO Panel Installation

In general, three principles guide the order of installing each panel assuming you are installing the panels from the exterior:

- Start at the interior-most track and work your way to the exterior-most track.
- On each track, install operating panels first, then stationary panels next.
- On tracks that have only stationary panels, work your way over from the jamb.

NOTE: The "L" or "R" with the letter designation signifies if the panel is on the left or right side of the walk-through opening as viewed from the exterior.

Use the following figure to further guide you on the order of panel installation.

- Install A and E panels first
- Install the H panel next
- Install both C panels last

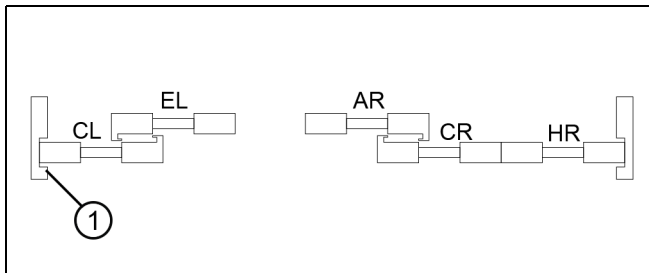

Figure 126 OX-XOO RH shown

1	Exterior side
---	---------------

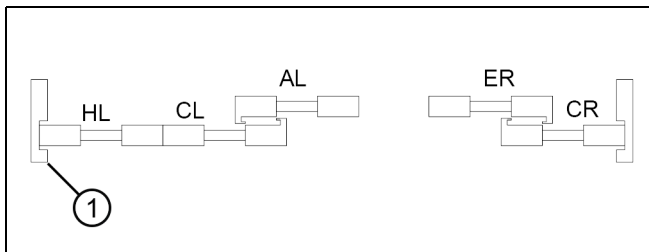

Figure 127 OOX-XO LH shown

1	Exterior side
---	---------------

IMPORTANT

Steps and illustrations that follow will show an OX-XOO configuration. The order of panel installation is mirrored for OOX-XO. Illustrations are shown from the exterior unless noted otherwise.

1. Measure the (H) stationary panel OM. Transfer that measurement to the interior track of the head jamb and center the top stationary bracket at that distance. See [Figure 128](#) and [Figure 129](#).

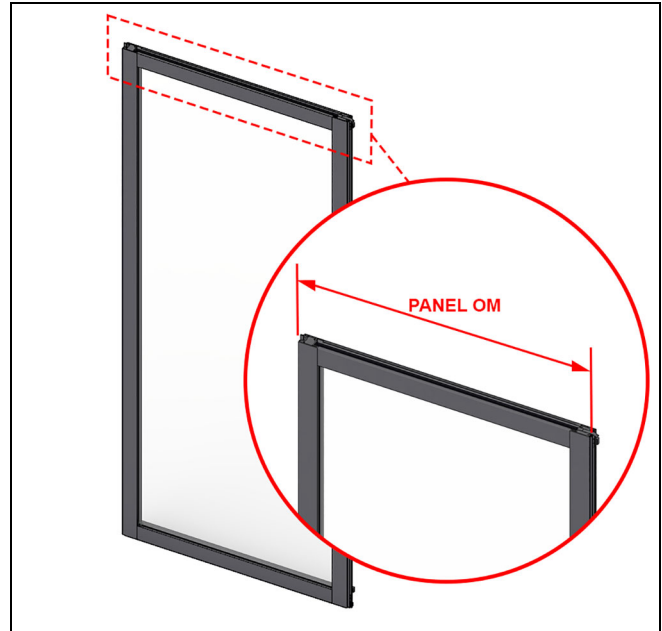

Figure 128

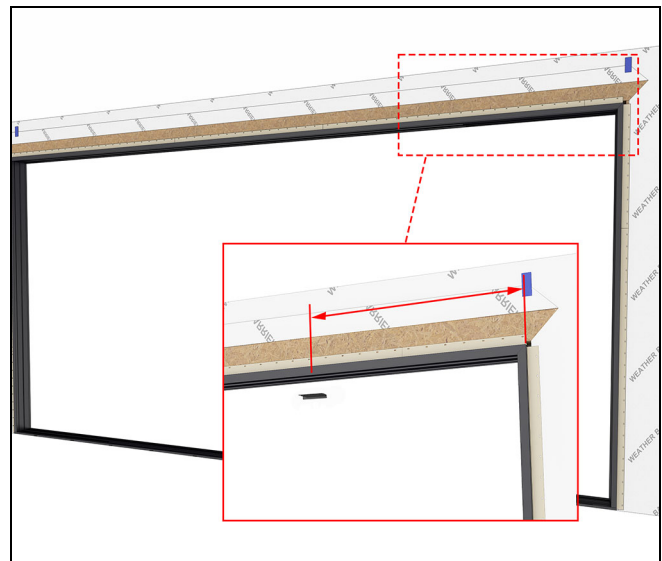

Figure 129

NOTE: If the bracket ends up on top of an installation screw, remove screw and shift the bracket left or right so that a hole in the bracket lines up with the installation hole. Reinstall previously removed screw.

2. Pre-drill a 3/16" hole through the head jamb using the bracket as a template. Pre-drill at each outside hole of the bracket, and at least once more in the middle of the bracket. See Figure 130.

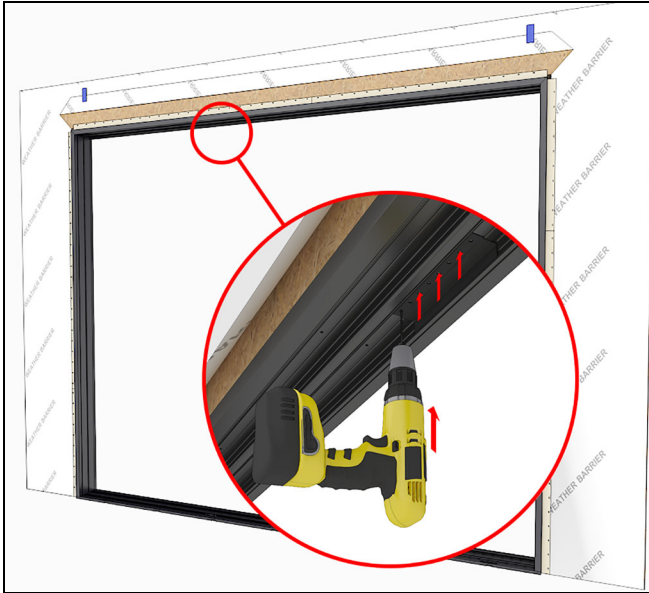

Figure 130

3. Fasten through the bracket into the head jamb framing with #10 x 3" installation screws at each pre-drilled location. Shim above the bracket as needed. See Figure 131.

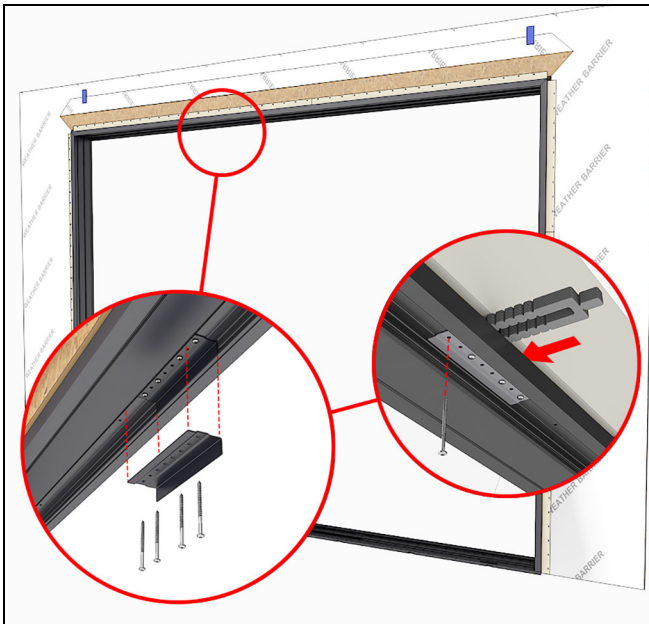

Figure 131

4. Install the (A) primary panel and (E) inactive panel on the interior track. See Figure 132.

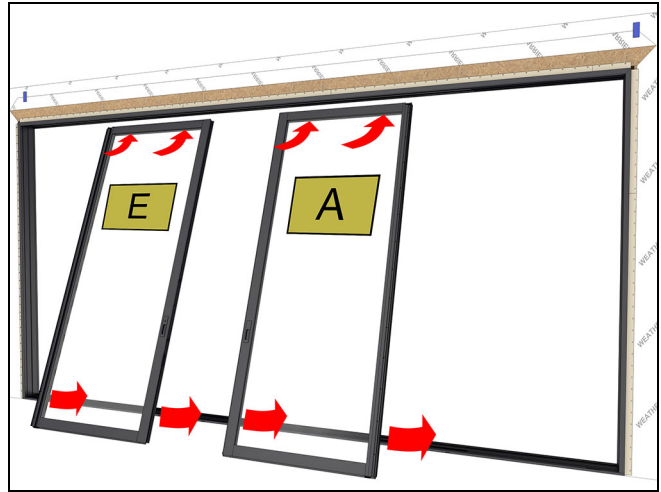

Figure 132

5. Install the (H) stationary panel on the exterior track, slide the panel tight against the stationary jamb. Measure from the jamb to the edge of the daylight opening. This should be about 2 5/8". See Figure 133 and Figure 134.

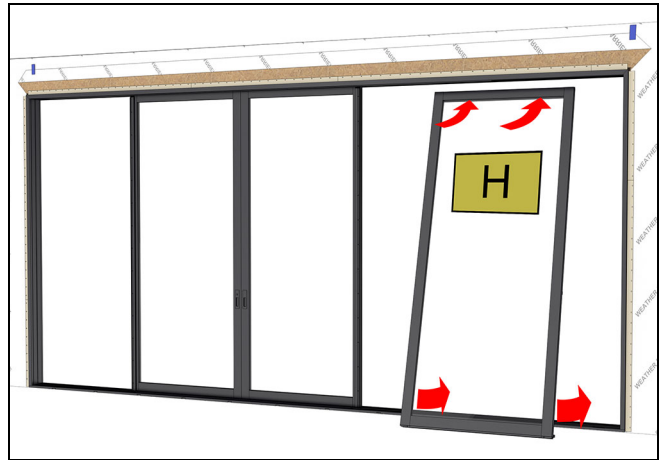

Figure 133

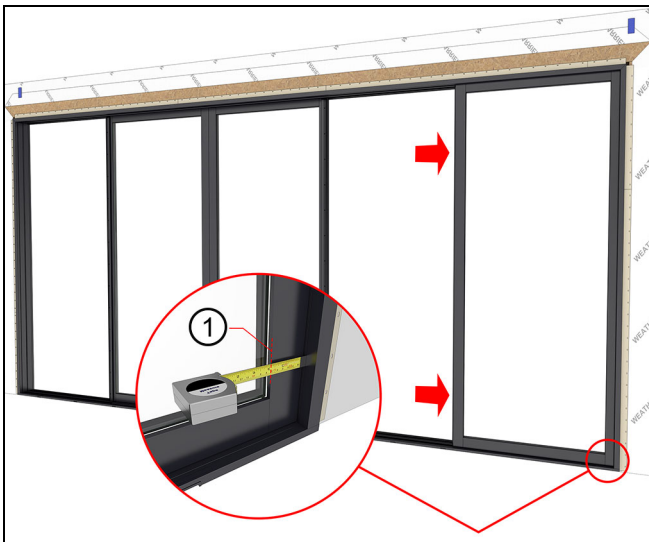

Figure 134

1	2 5/8"
---	--------

6. Snap the lower stationary bracket onto sill, then slide underneath the (H) stationary panel until fully seated. The bracket should stick out approximately 2 1/4" (57) from panel when fully seated. Fasten with #8 x 1/2" self drilling screw. See Figure 135.

NOTE: When seated properly, one of the small dimples on the lower stationary bracket will be hidden.

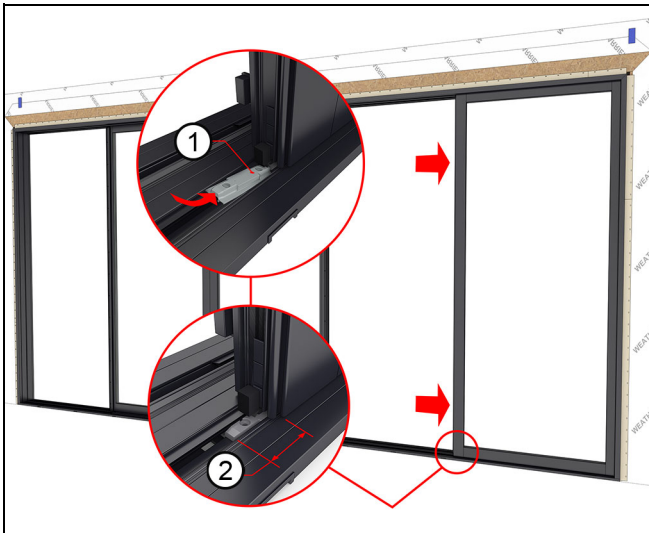

Figure 135

1	Lower stationary bracket
2	2 1/4"

7. Move the (A) operator panel toward the right side jamb about 12" from the (H) stationary panel. See Figure 136.

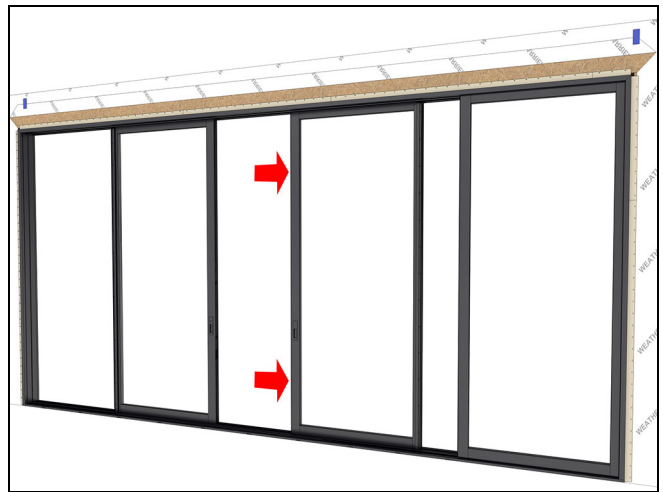

Figure 136

8. Install the (C-R) stationary panel on the exterior track, making sure the panel overlaps the (A) operator panel to leave room for the interlocks to clear. See Figure 137.

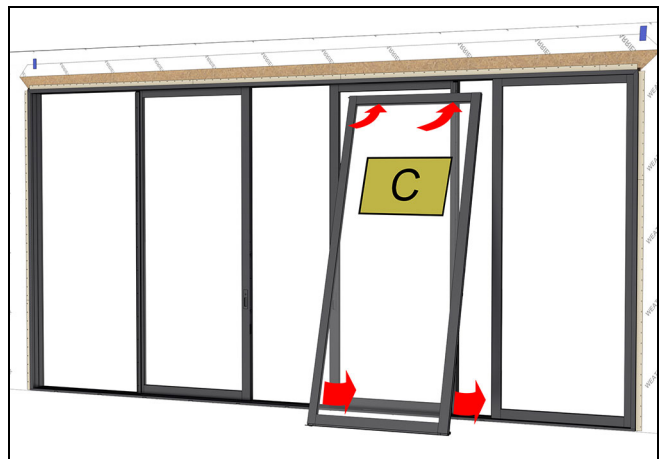

Figure 137

9. Slide the (C) panel over tight against the (H) stationary panel. Check to make sure you have an even reveal along the panel. The gap should be about 1/4" or less. See Figure 138.

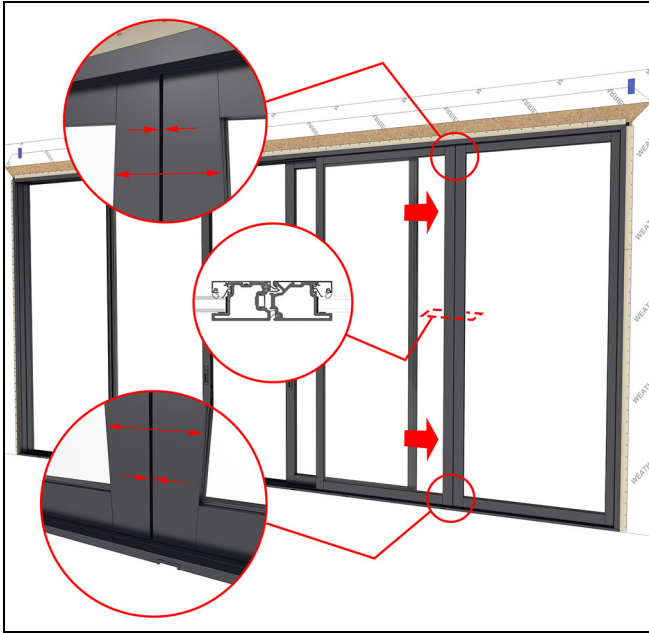

Figure 138

10. Snap the lower stationary bracket onto sill, then slide underneath the (C) stationary panel until fully seated. The bracket should stick out approximately 2 1/4" (57) from panel when fully seated. Do not fasten the bracket until all the panels are installed and adjusted. See Figure 139.

NOTE: When seated properly, one of the small dimples on the lower stationary bracket will be hidden.

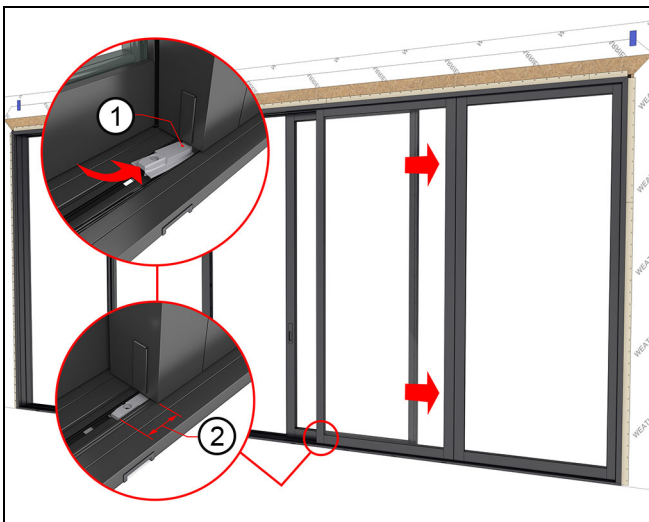

Figure 139

1	Lower stationary bracket
2	2 1/4"

11. Slide the (E) operator panel about 12" from the jamb. See Figure 140.

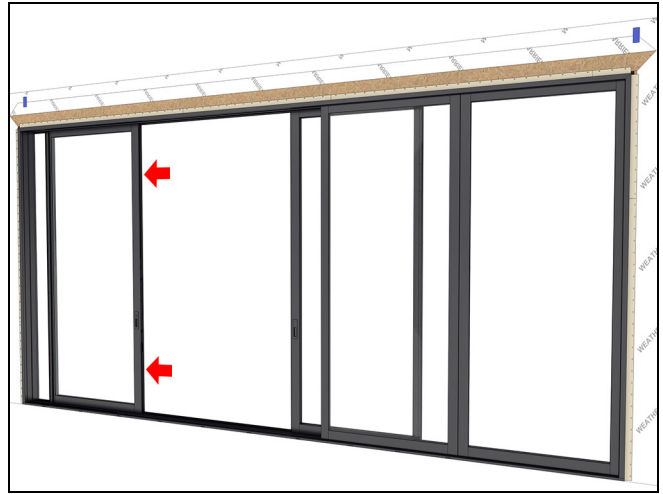

Figure 140

12. Install the (C-L) stationary panel onto the exterior track, slide the panel tight against the stationary jamb. The measurement from the inside of the exterior frame to the edge of the daylight opening should be 2 5/8" when the panel is fully seated inside the jamb. See Figure 141 and Figure 142.

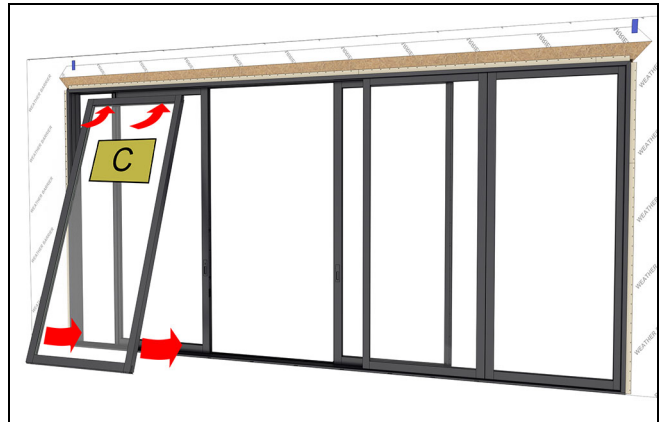

Figure 141

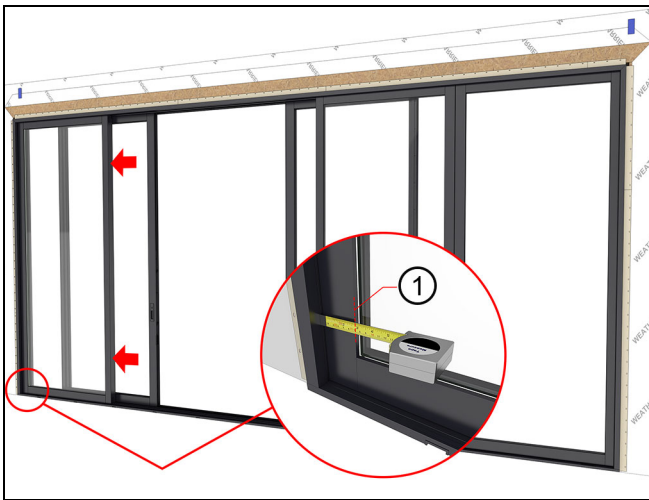

Figure 142

1	2 5/8"
---	--------

13. Snap the lower stationary bracket onto sill, then slide underneath the (C-L) stationary panel until fully seated. The bracket should stick out approximately 2 1/4" (57) from panel when fully seated. Do not fasten the bracket until all the panels are installed and adjusted. See Figure 143.

NOTE: When seated properly, one of the small dimples on the lower stationary bracket will be hidden.

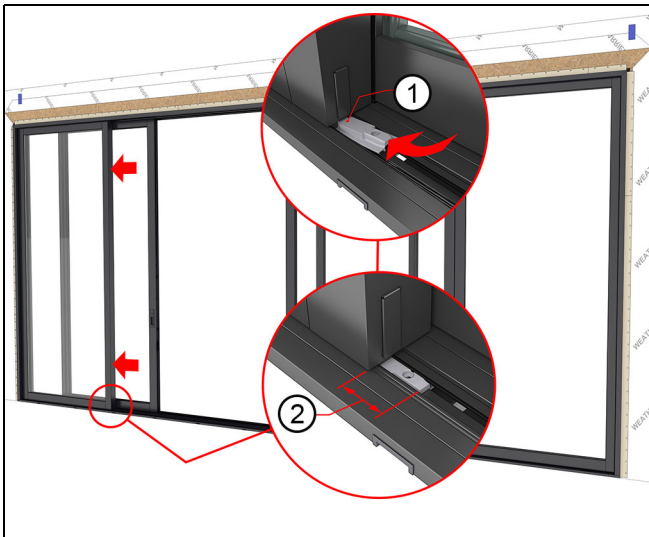

Figure 143

1	Lower stationary bracket
2	2 1/4"

14. Close and lock the (A) and (E) operator panels. Check the operator panel for an even reveal. Adjust panel rollers as needed for proper lock engagement and reveal. See Figure 144.

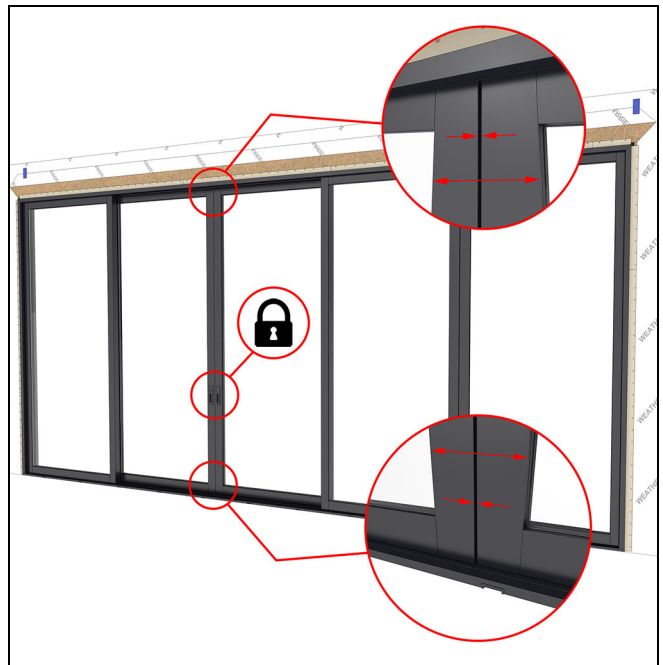

Figure 144

15. Bend the top stationary bracket of the (C) stationary panels up against the head jamb, pre-drill a 3/16" hole through the head jamb using the bracket as a template. Fasten through the bracket into the head jamb framing with a #10 x 3" installation screw. Shim as needed taking care not to bow the head jamb.

Fasten the lower stationary brackets on the (C) panels with a #8 x 1/2" screw. See Figure 145.

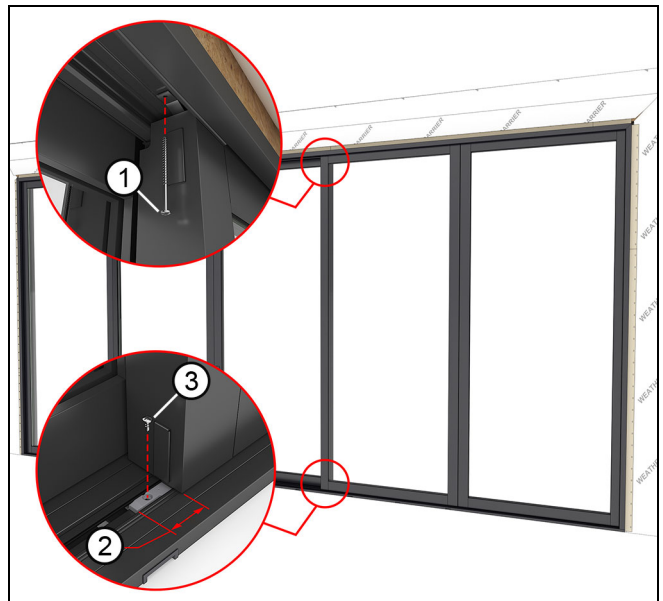

Figure 145

1	#10 x 3" Installation screw
2	2 1/4"
3	#8 x 1/2" Self drilling screw

XOX Panel Installation

NOTE: Illustrations in this section are shown from the exterior unless noted otherwise.

In general, two principles guide the order of installing each panel assuming you are installing the panels from the exterior:

- Start at the interior-most track and work your way to the exterior-most track.
- On each track, install operating panels first, then stationary panels next.

NOTE: The "L" or "R" behind the letter designation signifies if the panel is on the left or right side of the walk-through opening as viewed from the exterior.

Use the following figure to further guide you on the order of panel installation.

- Install A panels first
- Install K panel last

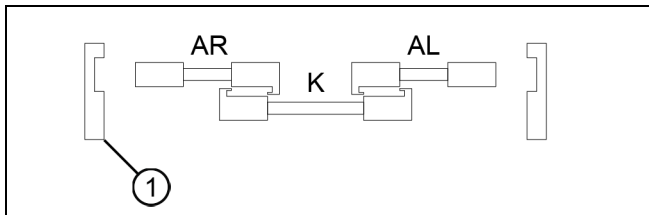

Figure 146 XOX

1	Exterior side
---	---------------

1. Install the (A) primary panels on the interior track. See Figure 147.

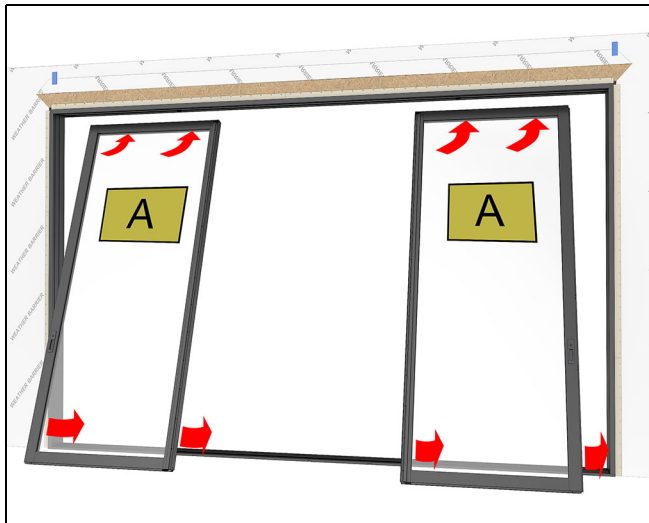

Figure 147

2. Close and lock the panels. See Figure 148.

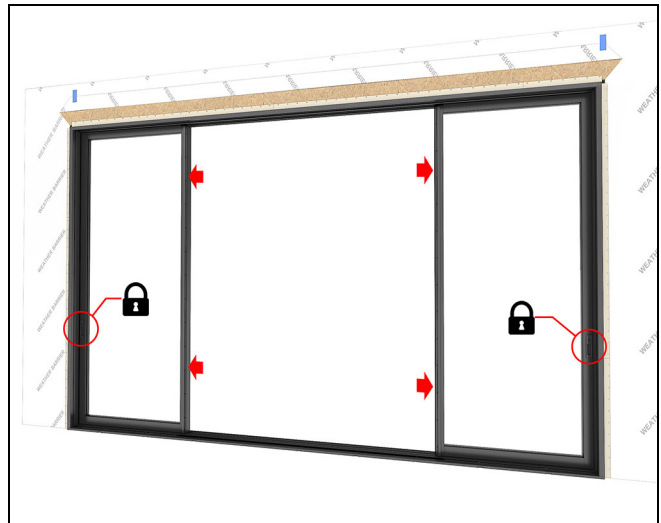

Figure 148

3. Place two pieces of tape on the sill at the daylight opening (interlock stile side) of the operator panels. This will help position the stationary panel correctly.



Tip

When installed correctly, the outside edges of the stationary panel will align with the daylight opening of the operator panels. See Figure 149

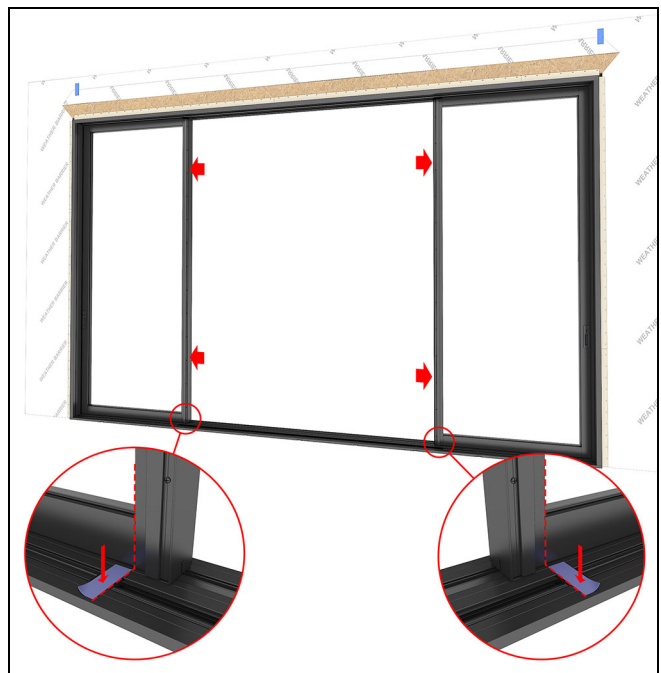

Figure 149

4. Unlock and move the operator panels away from the jambs about 12". See Figure 150.

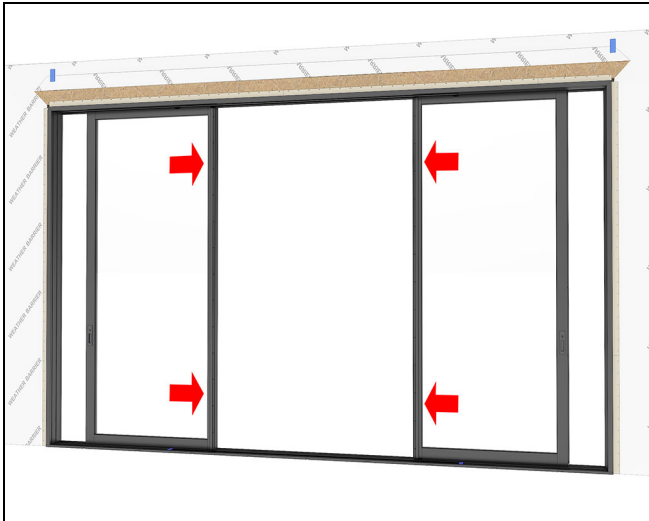

Figure 150

5. Install the (K) stationary panel. Line up the left outside edge of the panel with the left mark made on the sill earlier in step 3 on page 47. See Figure 151 and Figure 152.

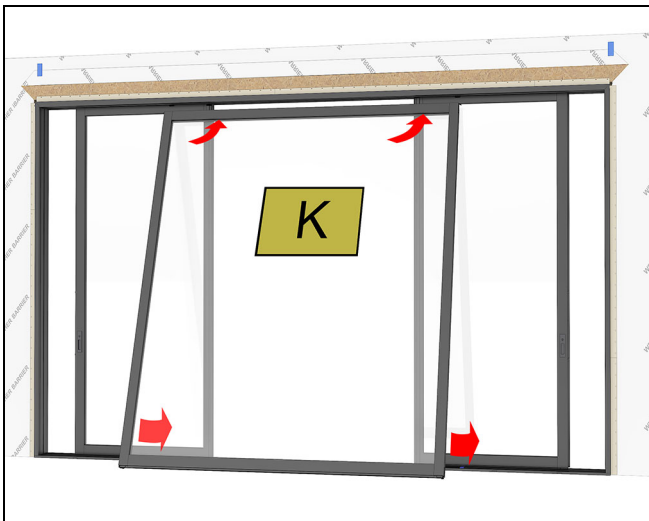

Figure 151 XOX shown with K panel

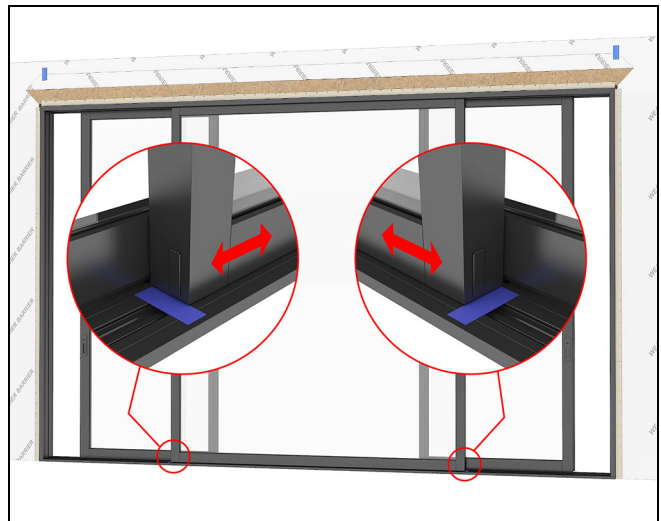

Figure 152

6. Close and lock the operator panels. The interlocks should engage and the stationary panel may move slightly. If the stationary panel did not move, firmly slide the stationary panel opposite the closing direction of the operator panel to fully engage the interlocks. See Figure 153.

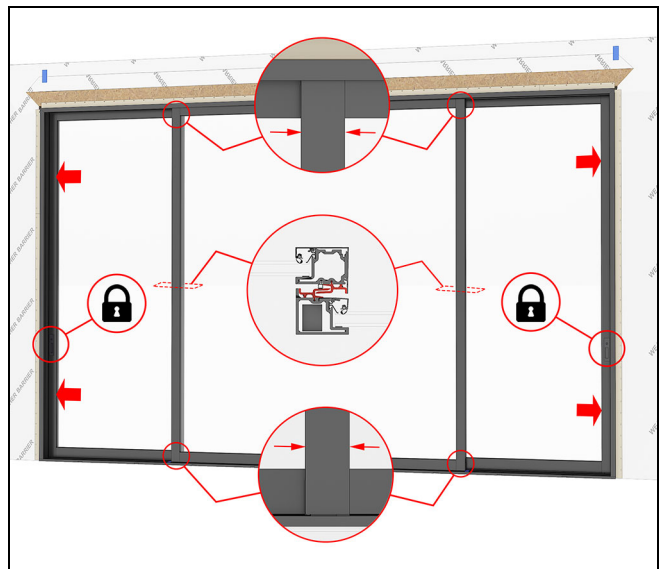

Figure 153 XOX shown

7. On both sides of the (K) panel, snap the lower stationary brackets onto sill, then slide underneath the stationary panel until fully seated. Each bracket should stick out approximately 2 1/4" (57) from the panel when fully seated. Fasten the brackets with #8 x 1/2" self drilling screws. See Figure 154.

NOTE: When seated properly, one of the small dimples on the lower stationary brackets will be hidden.

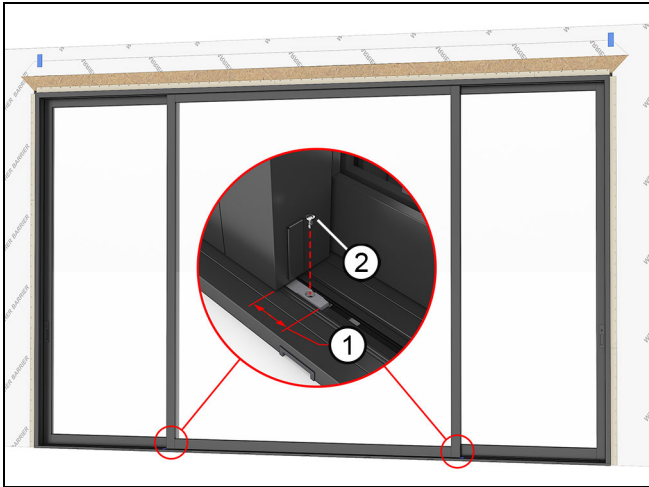

Figure 154 XOX

1	2 1/4"
2	#8 x 1/2" self drilling screws

8. Bend the top stationary brackets of the (K) stationary panel up against the head jamb, pre-drill a 3/16" hole using the bracket as a template. Fasten through the brackets into the head jamb with #10 x 3" installation screws. Shim as needed taking care not to bow the head jamb. See Figure 155.

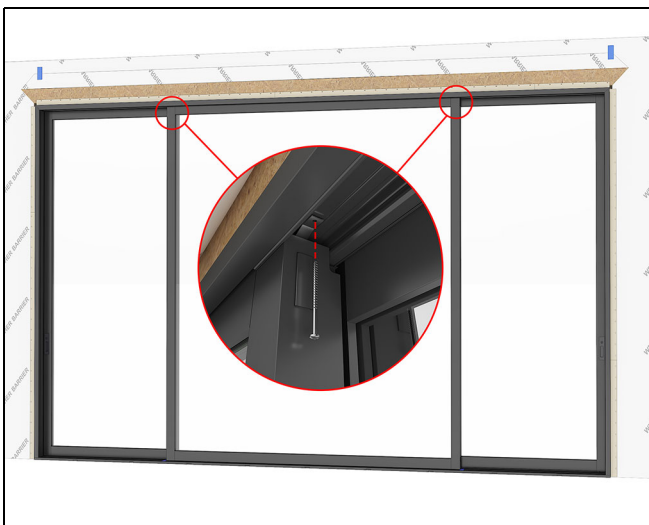

Figure 155 XOX

9. Install the bumper brackets on the rails of the (K) stationary panel. Orient the brackets so the tabs are

pointed left (as seen from the interior). There is a mating surface on the back side of the bracket that fits into the panel rout. Fasten with #10 x 1 1/2" (38) Phillips head screws. Insert the rubber bumpers over the brackets with the wider section facing left. If rails have two sets of bumpers, orient them in opposing directions. See Figure 156.

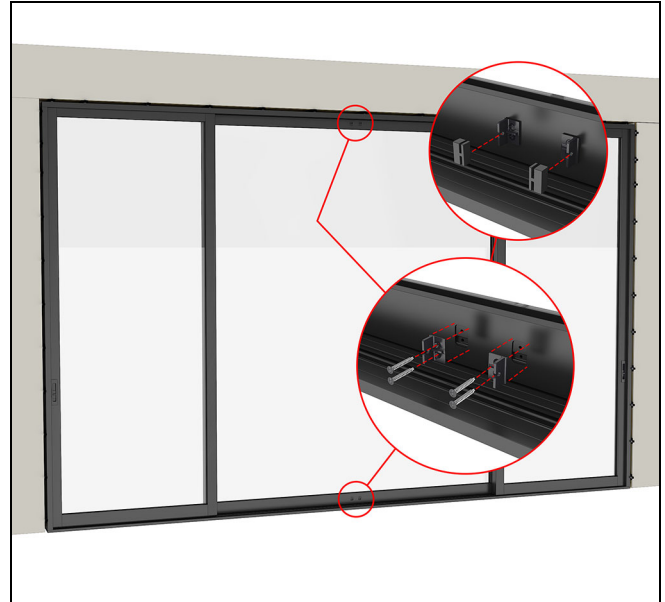

Figure 156 XOX Interior view

10. Open both operator panels until each contacts their respective bumpers. Verify that the outside of the panels are flush with the stationary panel to confirm proper bumper bracket and bumper rubber orientation.

XOOX Panel Installation

NOTE: Illustrations in this section are shown from the exterior unless noted otherwise.

In general, two principles guide the order of installing each panel assuming you are installing the panels from the exterior:

- Start at the interior-most track and work your way to the exterior-most track.
- On each track, install operating panels first, then stationary panels next.

NOTE: The "L" or "R" behind the letter designation signifies if the panel is on the left or right side of the walk-through opening as viewed from the exterior.

Use the following figure to further guide you on the order of panel installation.

- Install A panels first
- Install J&C panels last

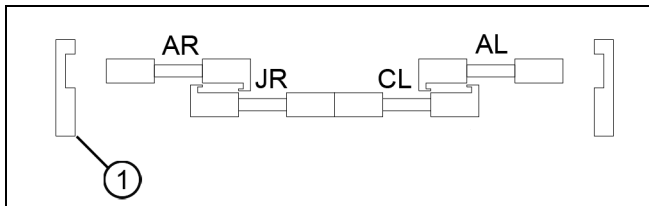

Figure 157 XOOX

1	Exterior side
---	---------------

1. Measure the net clear opening width of the frame and divide the value by two. Transfer that measurement to the exterior track of the head jamb and center the top stationary bracket at that measurement. See Figure 158.

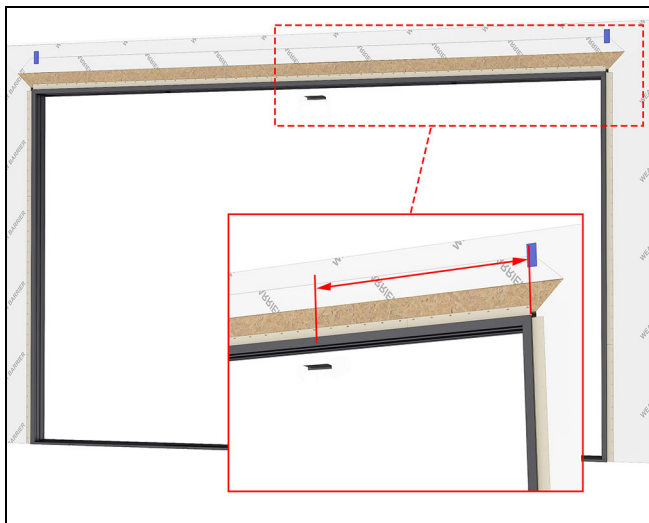

Figure 158 XOOX

NOTE: If the bracket ends up on top of an installation screw, remove screw and shift the bracket left or right so that a hole in the bracket lines up with the installation hole. Reinstall previously removed screw.

2. Using the bracket as a template, pre-drill a 3/16" hole at each outside hole and at least once more in the middle. See Figure 159 and Figure 160.

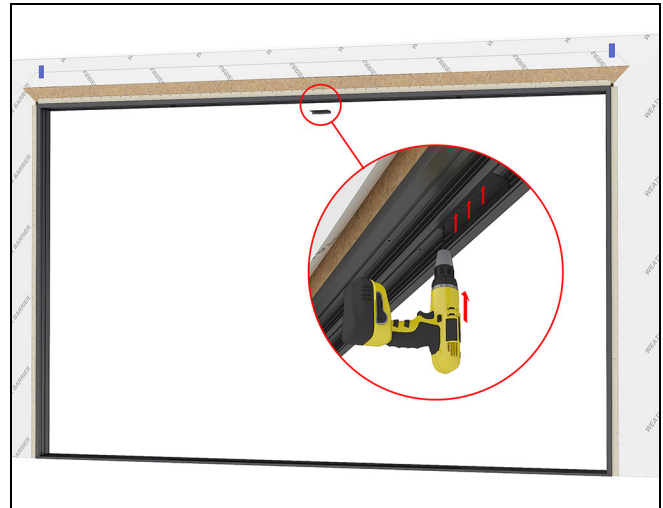

Figure 159 XOOX

3. Fasten through the bracket into the head jamb with #10 x 3" installation screws at each pre-drilled location. Shim above the head jamb at the bracket as needed. Be careful not to bow the headjamb. See Figure 160

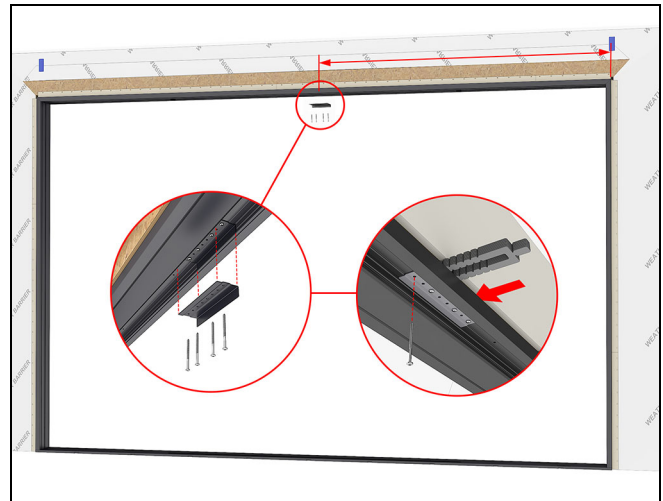

Figure 160 XOOX

4. Install the (A) primary panels on the interior track. See Figure 161.

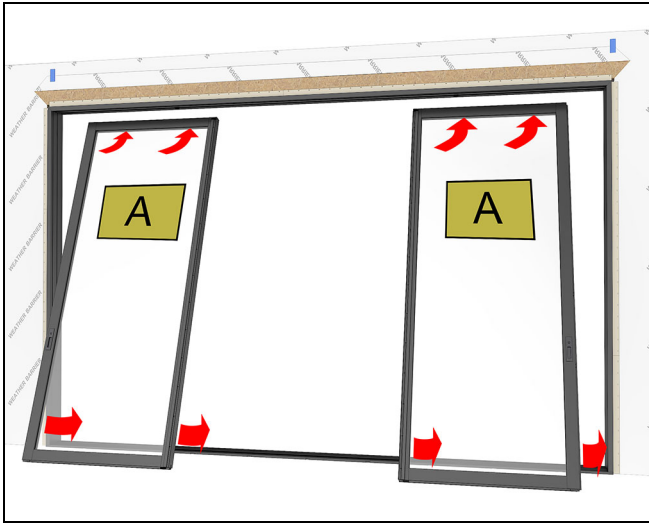

Figure 161

5. Close and lock the panels. See Figure 162.

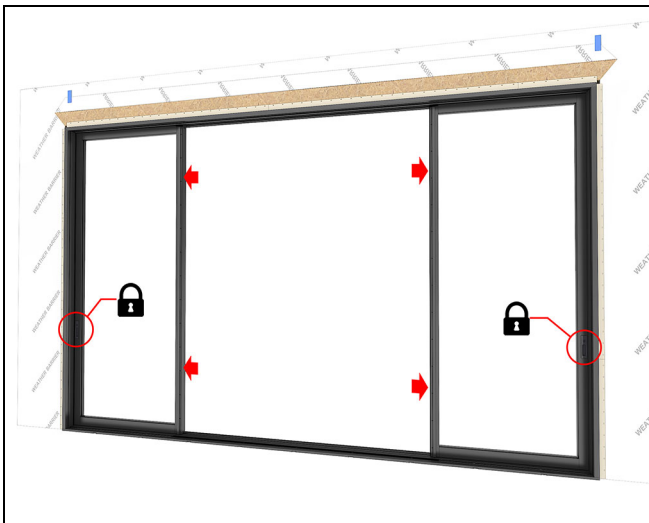

Figure 162

6. Place two pieces of tape on the sill at the daylight opening (interlock stile side) of the operator panels. This will help position the stationary panel correctly.



Tip

When installed correctly, the outside edge of each stationary panel will align with the daylight opening of the operator panel. See Figure 163

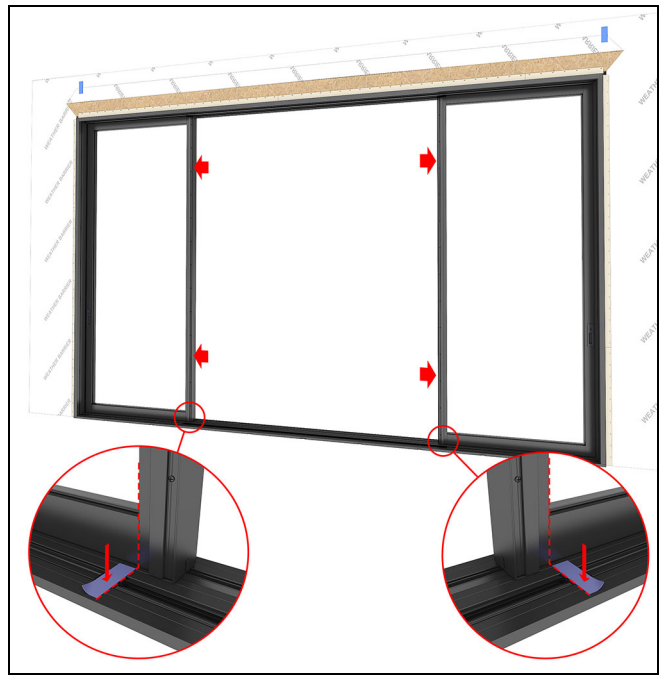

Figure 163

7. Unlock and move the operator panels away from the jambs about 12". See Figure 164.

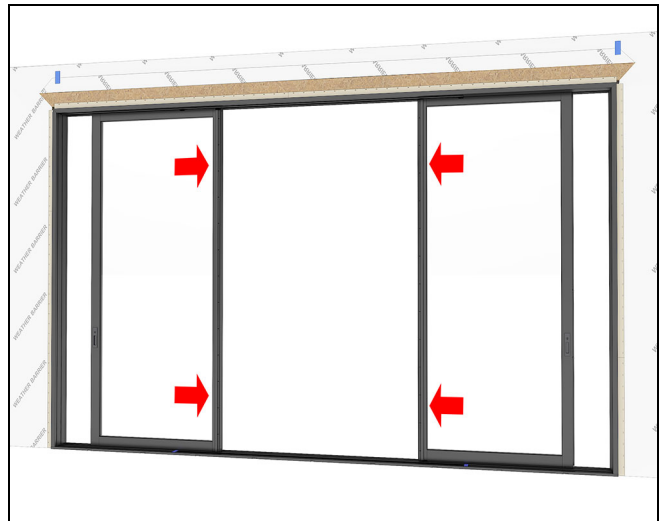

Figure 164

8. Install the (J) stationary panel. Line up the left outside edge of the panel with the left mark made on the sill earlier in [step 3 on page 47](#). See [Figure 165](#) and [Figure 166](#)

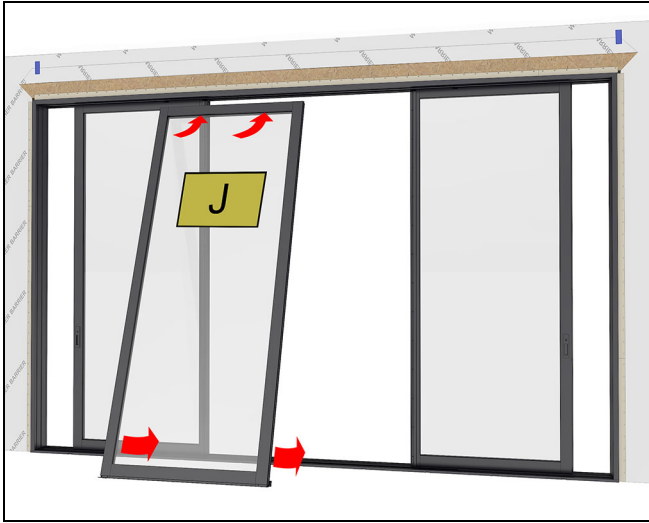

Figure 165 XOOX

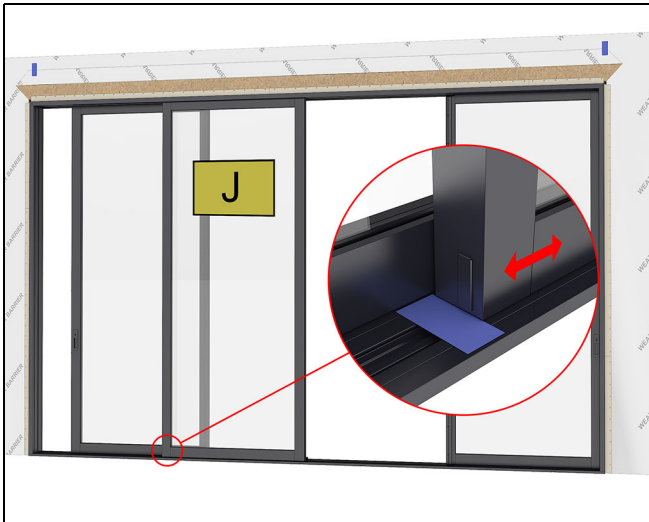

Figure 166

9. Close and lock the operator panel. The interlocks should engage and the stationary panel may move slightly. If the stationary panel did not move, firmly slide the stationary panel opposite the closing direction of the operator panel to fully engage the interlocks. See [Figure 167](#).

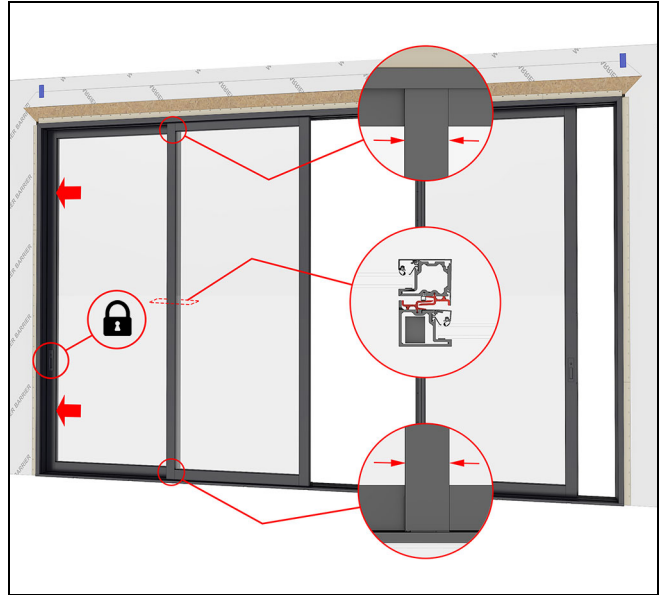

Figure 167 XOOX

10. On both sides of the (J) panel, snap the lower stationary brackets onto sill, then slide underneath the stationary panel until fully seated. Each bracket should stick out approximately 2 1/4" (57) from panel when fully seated. Fasten the brackets with #8 x 1/2" self drilling screws. See [Figure 168](#) and [Figure 169](#).

NOTE: When seated properly, one of the small dimples on the lower stationary bracket will be hidden.

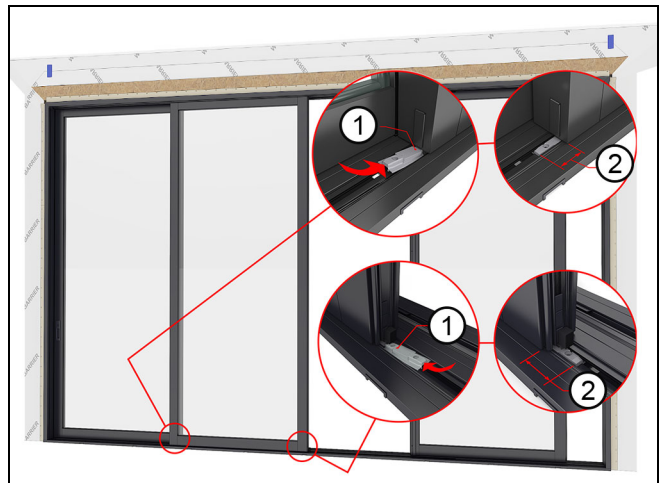

Figure 168 XOOX

1	Lower stationary bracket
2	2 1/4"

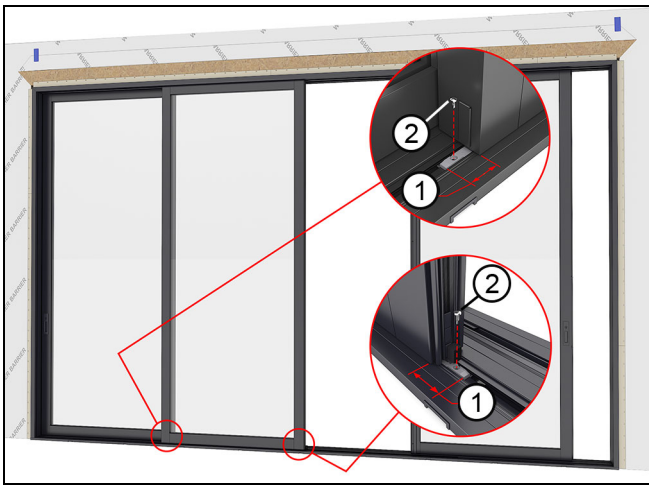

Figure 169 XOOX

1	2 1/4"
2	#8 x 1/2" self drilling screw

11. Install the (C) stationary panel. Slide the panel up tight against the (J) stationary panel. See Figure 170.

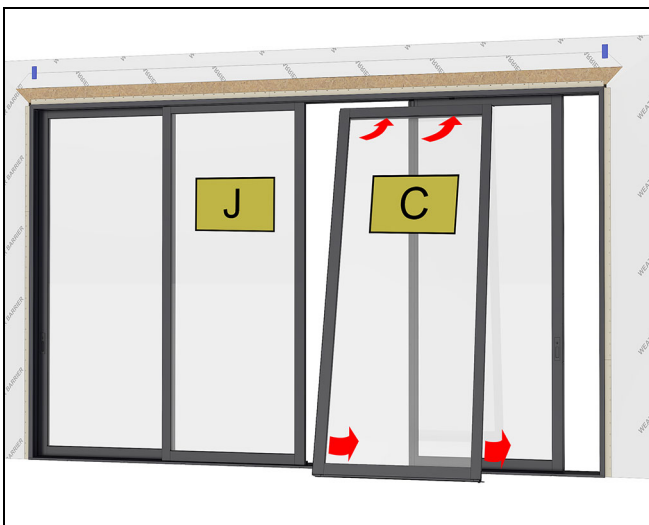

Figure 170 XOOX

12. Close and lock the second operator panel. Check all reveals and adjust as necessary. See Figure 171.

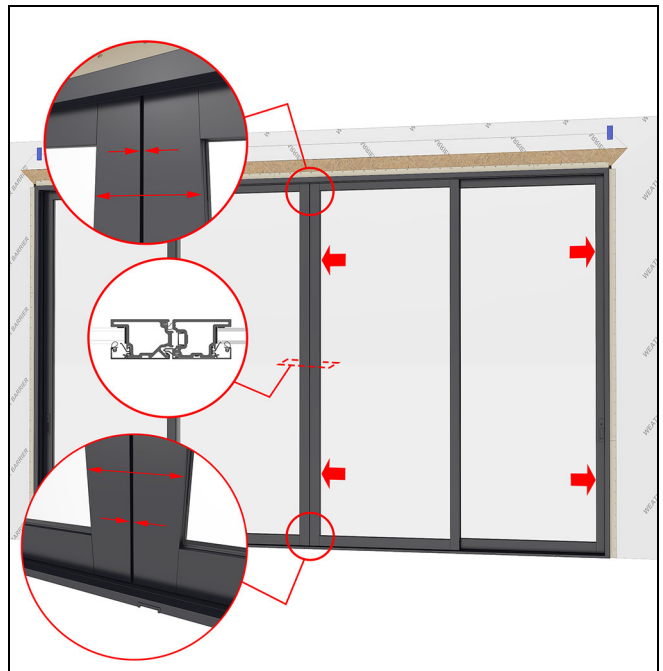

Figure 171

13. Snap the third and final lower stationary bracket onto sill, then slide underneath the (C) stationary panel until fully seated. The bracket should stick out approximately 2 1/4" (57) from panel when fully seated. Fasten the lower stationary bracket with a #8 x 1/2" self drilling screw. See Figure 172.

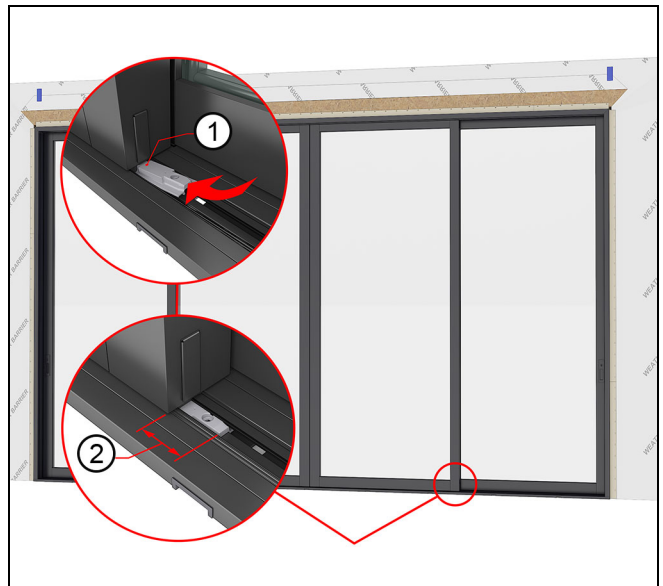

Figure 172

1	Bottom stationary bracket
2	2 1/4"

14. Bend the top stationary bracket of the (C) stationary panel up against the head jamb, pre-drill a 3/16" hole using the bracket as a template. Fasten through the bracket into the head jamb with a #10 x 3" installation screw. Shim as needed taking care not to bow the head jamb. See Figure 173.

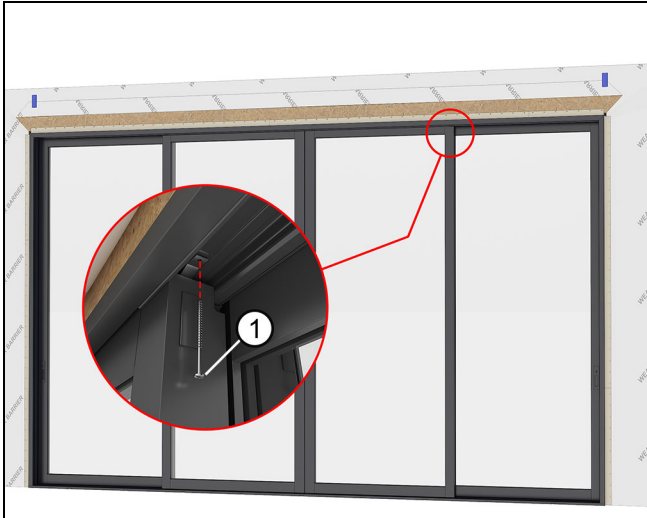

Figure 173 XOOX

1	#10 x 3" Installation screw
---	-----------------------------

15. Install the bumper brackets on the stile of the (J) panel. Orient the brackets so the tab is pointed to the left as seen from the interior. There is a mating surface on the back side of the bracket that fits into the panel rout. Fasten with #10 x 1 1/2" Phillips head screws. Insert the rubber bumper over the bracket with the wider section facing the left. See Figure 174

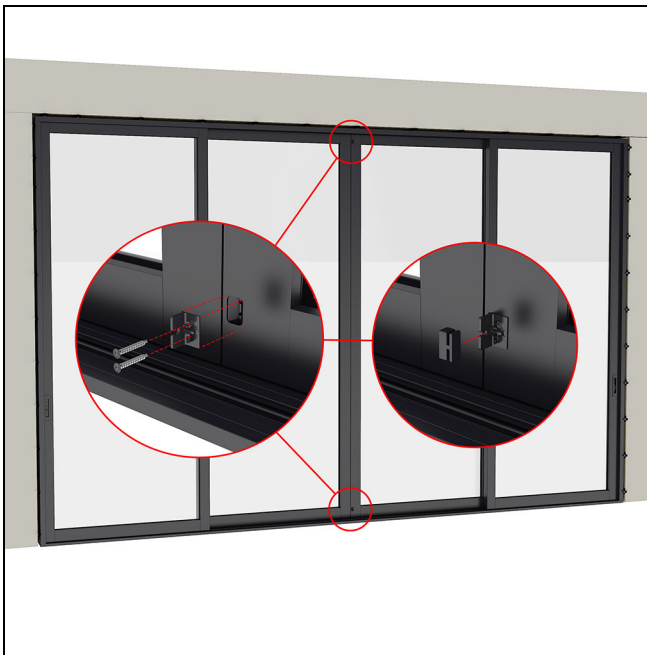

Figure 174 XOOX Interior view

Install Sill Frame Covers

Using a smartphone or similar device, scan the QR code below or click [here](#) to play a video of this procedure.



1. Where a cover meets a panel, insert a sill drain filter in the end of the cover before installing it in the sill. See [Figure 175](#).

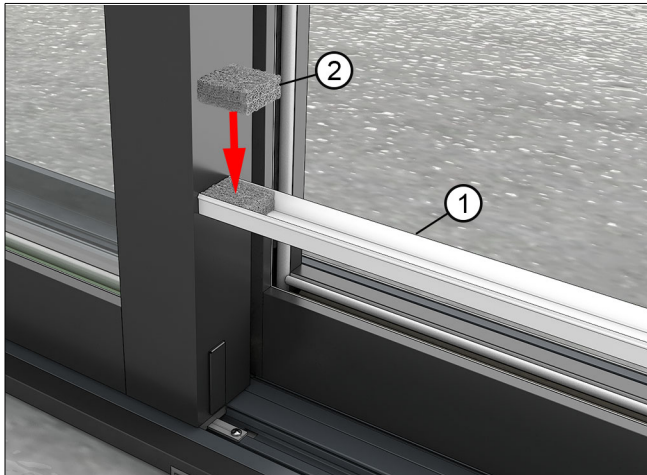

Figure 175 Uni-directional shown

1	Sill cover
2	Sill drain filter

2. Start with the panels closed and locked. The sill covers fit between the stationary panel or secondary panels on the exterior and the jambs. Seat the cover with a rubber mallet. The cover will fit slightly under the stationary panel. See [Figure 176](#), [Figure 177](#) and [Figure 178](#).

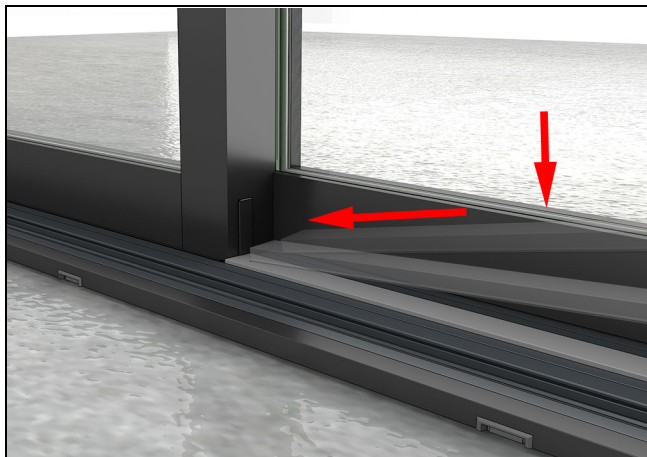

Figure 176

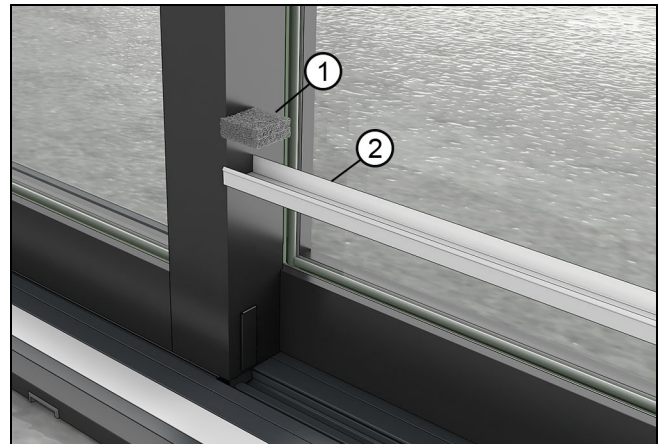

Figure 177

1	Sill drain filter
2	Sill cover (between secondary panel and locking jamb)

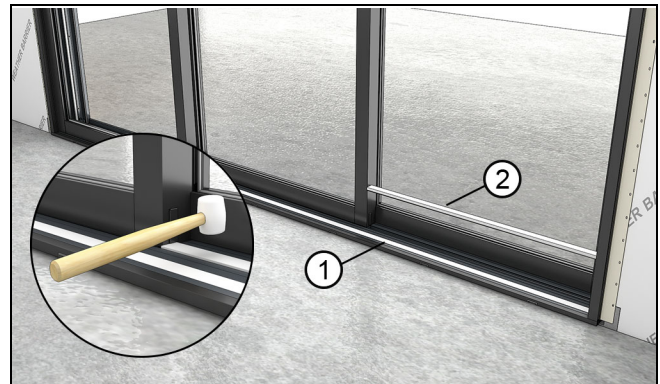

Figure 178

1	Cover between stationary panel and locking jamb
2	Cover between secondary panel and locking jamb

3. On bi-parting stacked configurations, fit the cover between the two stationary panels. The cover will come in two pieces. Slide the smaller of the two under one panel and pound into place. Fit one end of the longer piece under the other panel, then butt the other end in place and seat the cover with a rubber mallet. See [Figure 179](#).

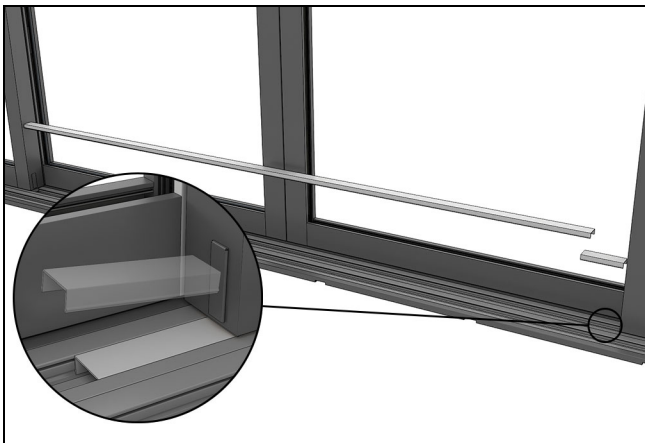

Figure 179 Bi-parting configurations (exterior cover shown)

Install Head Jamb Frame Covers

1. With all the panels closed, squeeze and insert a head jamb gasket adhesive side up into the head jamb track. Position the gasket flush with the panel(s). See [Figure 180](#).



Figure 180 Exterior

2. Starting from the exterior, install the head jamb covers. The covers have a leg that fits into a kerf on the jamb weather strip or a kerf in the frame itself. Fit the leg on the cover into the kerf on the jamb and rotate the cover into place. You may need to seat the cover with a rubber mallet. See [Figure 181](#), [Figure 182](#), and [Figure 183](#).

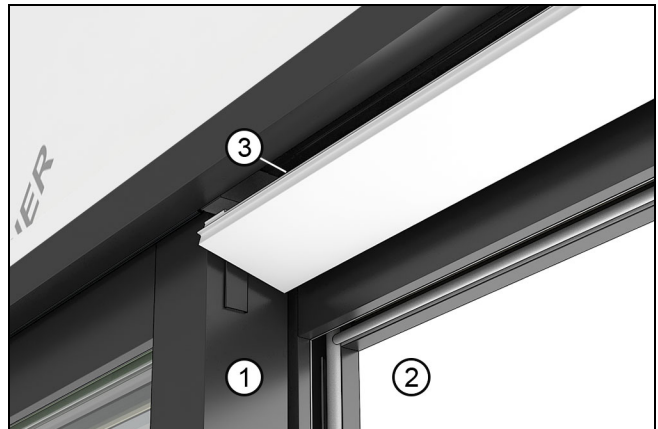

Figure 181 Exterior frame covers

1	Stationary panel
2	Secondary panel
3	Head Jamb frame cover



Figure 182

1	Head jamb gasket
2	Head jamb cover

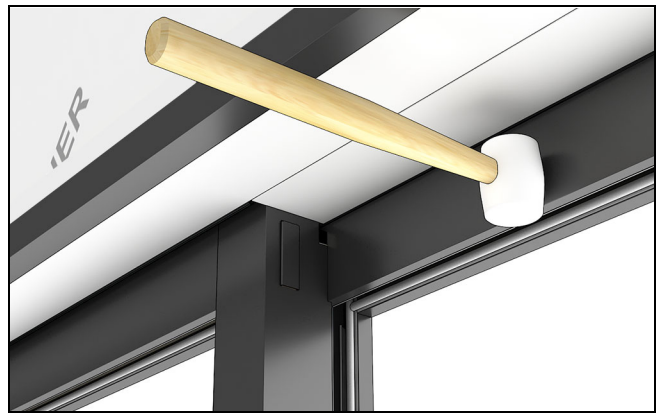

Figure 183

Install Jamb Frame Covers

NOTE: All covers are made from aluminum.

1. Install the exterior locking jamb covers. The covers have a leg that fits into a kerf on the jamb kerf in the frame. Fit the leg on the cover into the kerf on the jamb and rotate the cover into place. You may need to seat the cover with a rubber mallet. [See Figure 184.](#)



Figure 184

2. Install the interior stationary jamb covers. The covers have a leg that fits into a kerf on the jamb weather strip. Fit the leg on the cover into the jamb kerf and rotate the cover into place. You may need to seat the cover with a rubber mallet. [See Figure 185.](#)

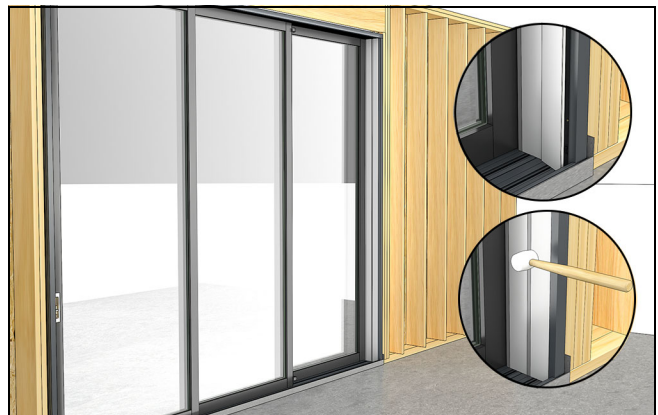

Figure 185

Adjusting Panels

1. Move the operator panel toward the locking jamb until there is a slight gap. Check for an even reveal/gap between the panel and the jamb. See Figure 186.

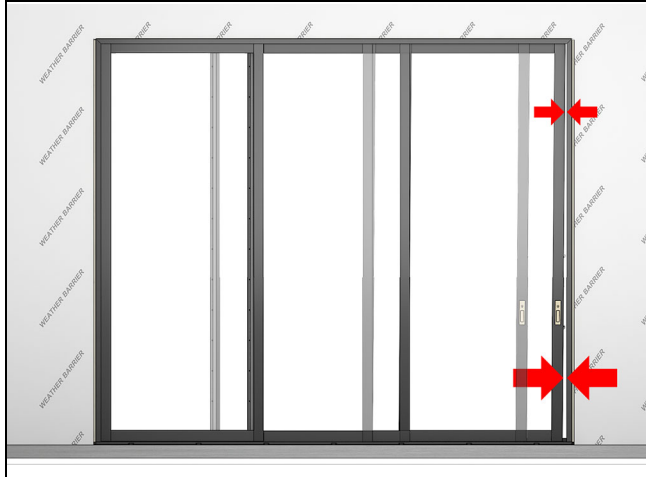

Figure 186

2. Place a block of wood on the sill and pry the panel up to relieve the weight off the rollers. See Figure 187.

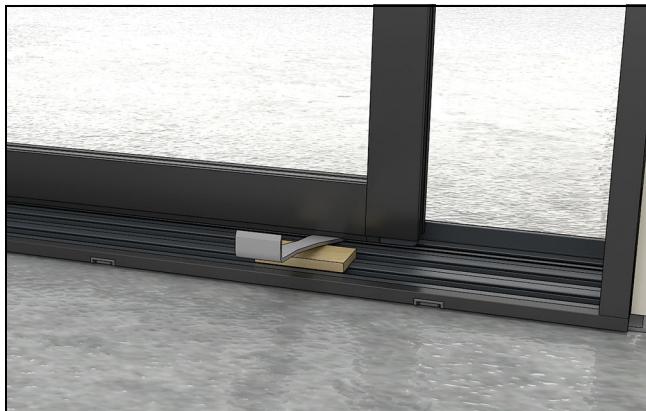

Figure 187

3. Remove the locking stile roller adjustment hole cover. See Figure 188.

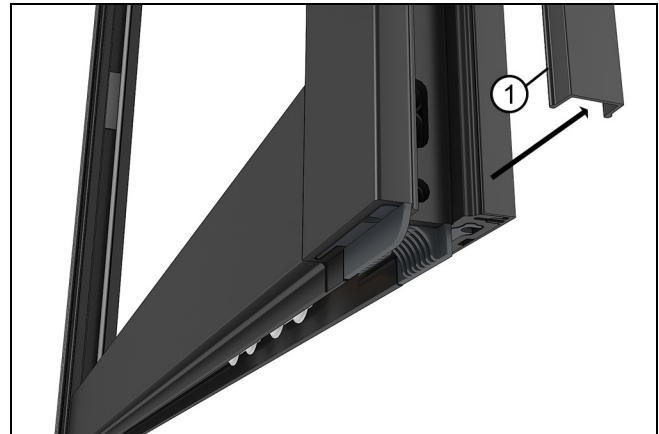

Figure 188

1	operator stile roller hole cover
---	----------------------------------

4. On inactive panels meeting stile side, pry the lower plug and dust cover down to reveal the adjustment hole. See Figure 189.

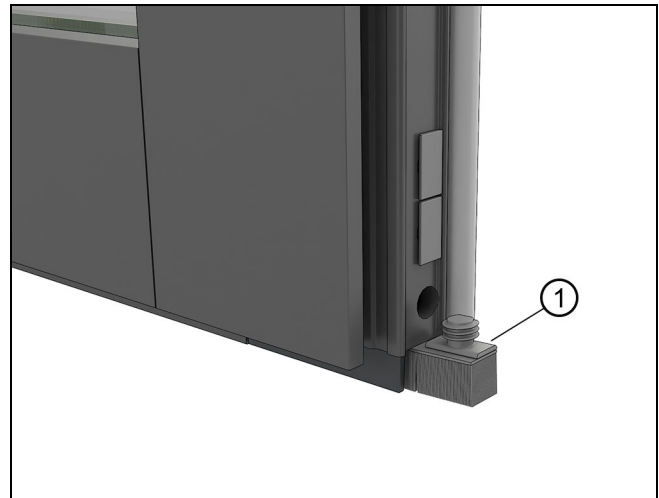

Figure 189

5. Insert a 5mm hex wrench into the adjustment hole(s) and raise or lower the rollers accordingly. Rotate the adjustment screw clockwise to raise the panels. See Figure 190 and Figure 191.

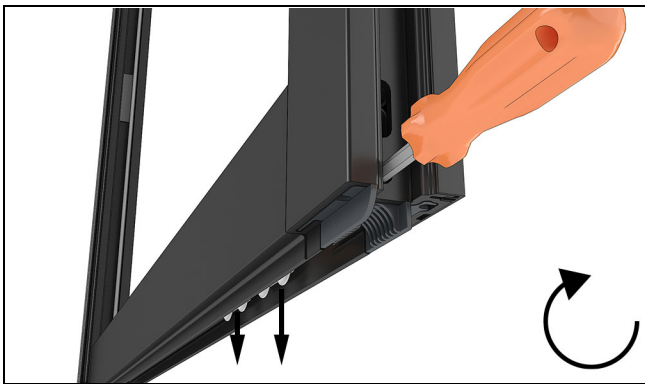

Figure 190

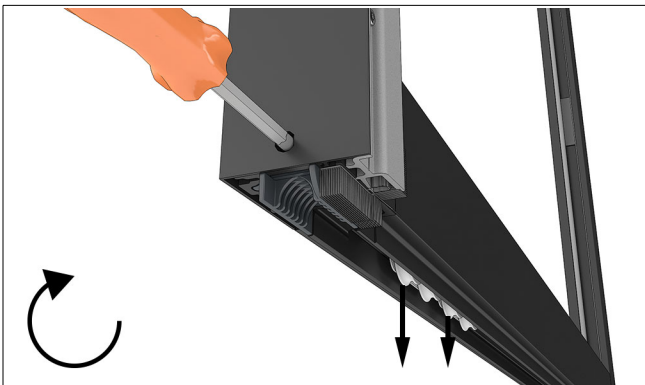

Figure 191

6. Recheck for an even reveal and repeat the previous steps if necessary. See Figure 192.

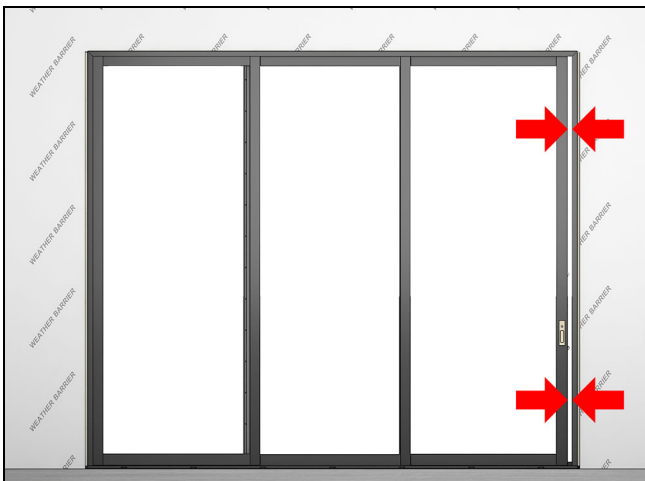

Figure 192

7. With the primary panel open slightly, move the secondary panel until you can see daylight through the glass between the stiles. Check for an even reveal and adjust the rollers on the secondary panel. Repeat as necessary for every secondary panel. See Figure 193.



Figure 193

8. Lock the primary panel and make sure the interlocks between the primary and secondary panel engage properly. See Figure 194.



Figure 194 Interior View: Close and lock primary panel

9. Insert hole plugs after you are done adjusting panels.

Install the HP Nosing

1. On all units with an HP sill, install the sill nosing into the groove on the exterior sill liner. Insert the "foot" of the nosing into the groove at an approximately 45 degree angle then rotate the part down into place until the long leg of the nosing contacts the sill frame/panning.

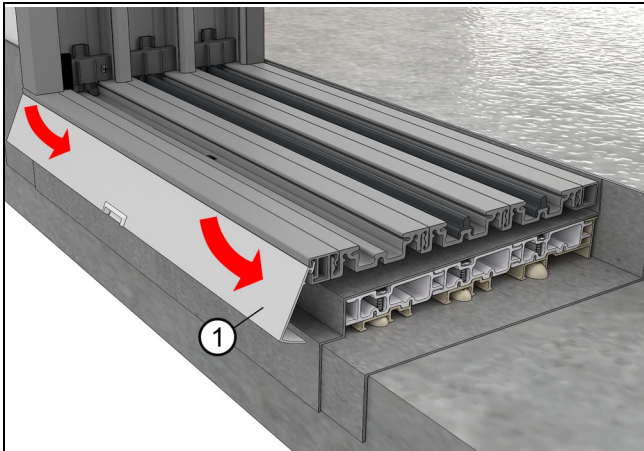

Figure 195

1	Sill nosing
---	-------------

2. Apply sealant around the end cap and then push the cap into the ends of the sill nosing.

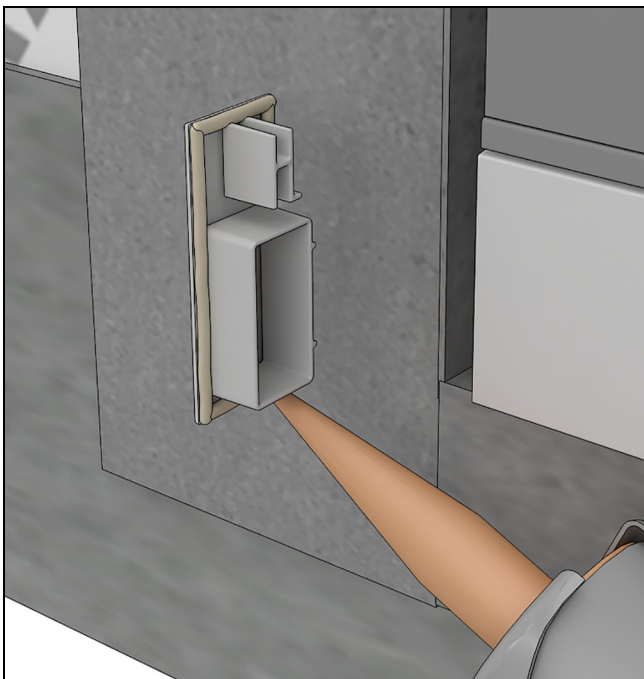

Figure 196

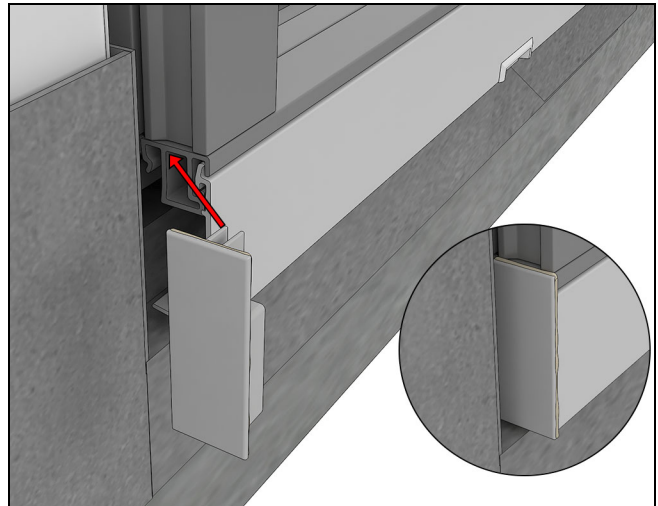

Figure 197

3. Seal the bottom of the entire length of the sill nosing leaving gaps at the sill weeps.

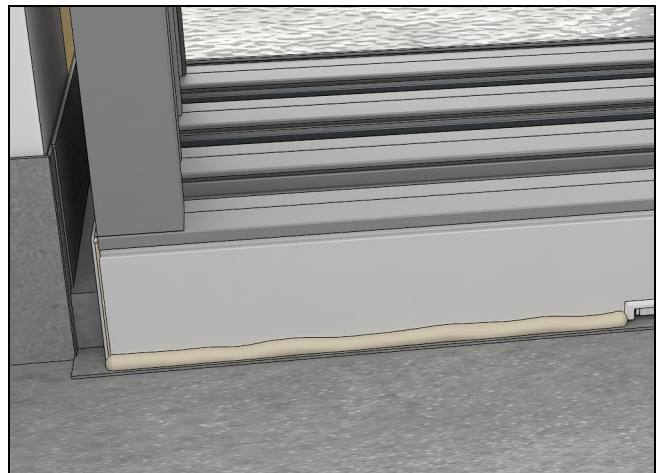

Figure 198

IMPORTANT

Do not allow sealant on the front face of the sill weeps on the sill nosing. Clean excess sealant immediately.

Technical Specifications

The following details are specified for proper installation of the unit to meet the advertised performance grade (PG) rating.

- Rough Opening Width: 1/4"-1 1/2" (6-38) wider than unit frame outside measurement.
- Rough Opening Height: 1/4"-1 1/2" (6-38) taller than unit frame outside measurement.
- Masonry Opening Width: 1/4"-1/2" (6-13) wider than unit frame outside measurement.
- Masonry Opening Height: 1/8"-1/4" (3-6) taller than unit frame outside measurement.

ATTENTION

Architectural Detail Manual Specifications:
Rough Opening: Width up to 1 1/2"(38); Height up to 3/4" (19)

Masonry Opening: Width 1/4"

- The panning must drain water to the exterior of the cladding OR the exterior surface of a concealed weather resistive barrier.

! CAUTION!

Be aware that the use of sill pans and other barriers will decrease the rough opening height clearance. Adjust opening dimensions accordingly.

- The panning system used in these instructions is one component in a structure's overall water management system. It should be used in conjunction with an appropriate drainage plane compatible with the exterior wall cladding.
- Flashing materials must comply with ASTM E2112, and be compatible with all materials used in installation including panning systems, air barriers and building papers, sheathing, and the window unit.
- Properly flash and/or seal all windows at the exterior perimeter.

IMPORTANT

Flashing material must not contain asphalt and must be compatible with flexible PVC (vinyl) if nailing fin is used as a backing material.

IMPORTANT

Sealants used for installation must be Grade NS Class 25 per ASTM C920 and compatible with the building exterior, window or door exterior surface, and flashing/water management materials.

- Optional foams used for installation must be low expansion only. Foam and foam application must comply with ASTM E2112.
- Shims are required at every fastener location.
- Do not use chemically treated products for shim material.
- Fasteners penetrating chemically treated lumber must be a minimum of 0.90 oz/ft² zinc hot dipped galvanized or stainless steel type 304 or 316.
- The frame must not come into direct contact with chemically treated wood products.