

ABSTRACT: Please read these instructions in their entirety before beginning to install your Elevate or Essential Exterior Casing. These installation instructions demonstrate the installation of exterior casing for window or door products.

Regional standard practices, environmental conditions, and codes may vary and supersede the procedures contained within. The responsibility for compliance is yours: the installer, inspector, and owner(s).

Installer and Builder Information

- Always provide a copy of these instructions for the current or future building owner.
- Contact your Marvin supplier if you have any questions regarding product and materials used in manufacturing or questions on replacement parts.

NOTE: Numbers listed in parentheses () are metric equivalents in millimeters rounded to the nearest whole number.

Exterior casing will be applied to window or door after unit is installed.

Exterior casing kits include cut to length profiles, to be assembled and applied in the field. (Lineal lengths are not pre-cut to specific door or window size.)



WARNING

Always practice safety! Wear the appropriate eye, ear and hand protection, especially when working with power tools.

Tool and Supplies

Tools Needed	
Phillips screwdriver	Utility scissors
Drill and 1/4" drill bit	Pry bar
Shims	
#6 (or greater) x 1" or greater Stainless steel/corrosion resistant fastener	
Clear sealant grade NS Class 25 per ASTM C920	
For cutting lineal lengths only:	
Continuous rim diamond blade/miter saw	

Outside Measurement Conversion for Exterior Casing

Measurement Conversion charts can be found on pages 22 (Essential) and 24 (Elevate).

Parts Kits- Depending on kit type, each package should contain the following parts and/or quantities.

Part	Kit Type/Quantity								
	BMC	BMC Sill Nosing	Flat Casing	Flat Casing Ranch Style	Flat Casing Sill Nosing	Flat Casing Ranch Sill Nosing	BMC Door	Flat Door	Flat Ranch Door
Corner key	4	4	4	4	4	4	2	2	2
Screw package (12)							1	1	1
Screw package (20)	1	1	1	1	1	1			
Reticulated foam	2	2	2	2	2	2			
Sill Nosing left hand end cap		1			1	1			
Sill Nosing right hand end cap		1			1	1			
Flat left hand end cap			2	2	1	1		2	2
Flat right hand end cap			2	2	1	1		2	2
BMC foam plug							2		
Instruction	1	1	1	1	1	1	1	1	1

Connection Barb Quantities for Windows	Width					
	0" to 35" (889)	+35" (889) to 59" (1499)	+59"(1499) to 83" (2108)	+83" (2108) to 107" (2718)	+107" (2717) to 131" (3327)	+131" (3327) to 155" (3937)
Height						
0" to 35" (889)	8	10	12	14	16	18
+35" (889) to 59" (1499)	10	12	14	16	18	20
+59"(1499) to 83" (2108)	12	14	16	18	20	22
+83" (2108) to 107" (2718)	14	16	18	20	22	24
+107" (2717) to 131" (3327)	16	18	20	22	24	26
+131" (3327) to 155" (3937)	18	20	22	24	26	28

Connection Barb Quantities for Doors	Width					
	0" to 35" (889)	+35" (889) to 59" (1499)	+59"(1499) to 83" (2108)	+83" (2108) to 107" (2718)	+107" (2717) to 131" (3327)	+131" (3327) to 155" (3937)
Height						
0" to 35" (889)	6	7	8	9	10	11
+35" (889) to 59" (1499)	8	9	10	11	12	13
+59"(1499) to 83" (2108)	10	11	12	13	14	15
+83" (2108) to 107" (2718)	12	13	14	15	16	17
+107" (2717) to 131" (3327)	14	15	16	17	18	19
+131" (3327) to 155" (3937)	16	17	18	19	20	21

Installation Preparation

A high pressure skirt is recommended prior to installing the casing. For more information on installation and rough opening preparation, please see [Rough Opening Preparation Instructions](#).

1. Ensure area around frame is clear and free of projections. Also that there is enough area around the unit frame for the casing outside measurement using chart on Page 1 for specific configuration.
2. Install a high pressure skirt. Use flashing material or a 12" (305) strip of WRB (weather resistive barrier) and attach to the sill of the window with seam seal tape or flashing tape. See *figure 1*.



Figure 1

3. Install another layer of adhesive membrane lapping onto head jamb of unit and over sheathing. Membrane flashing at head jamb should extend and cover flashing membrane previously installed at jambs. See *figure 2*.



Figure 2

Connection Barb

1. Casing installation requires a minimum window or door projection of 1" (25). Projections greater than 1" (25) may require connection bars to be shimmed away from the sheeting/WRB (weather resistive barrier) for compensation. See *figure 3*.

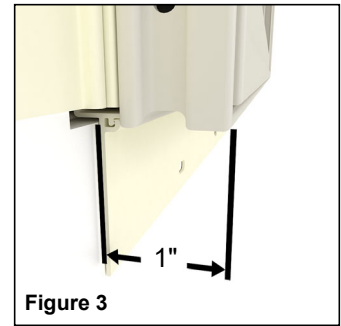

2. Apply casing connection barb to the perimeter of the unit using the step in the profile to align with the unit frame with a minimum spacing of 2 1/2" (63) and a maximum spacing of 4" (102) from each corner (spaced a maximum of 24" (610) on center). See *figure 4*.

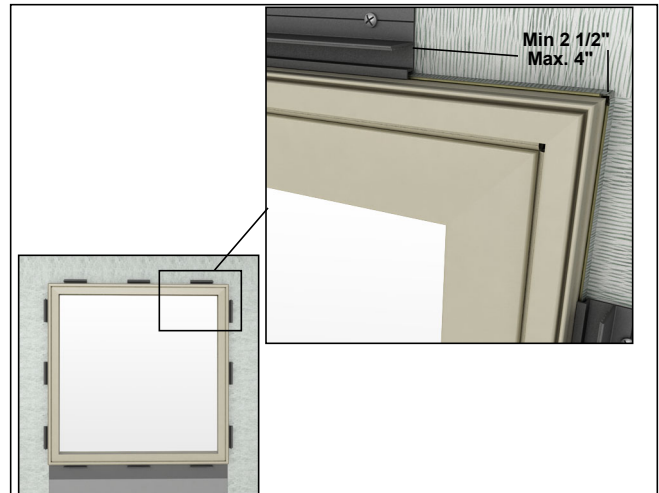

Figure 4

3. Two #6 or greater x 1" (25) or greater corrosion resistant fasteners are recommended for each connecting barb. Apply fasteners through the barb at the fastener indicator along the barb length. See *figure 5*.



Figure 5

Follow casing instructions specific to your configuration:

Table of Contents

BMC Assembly.....	4
BMC with Sill Nosing Assembly.....	5
Flat Casing Assembly.....	7
Flat Casing Ranch Assembly.....	9
Flat Casing with Sill Nosing Assembly.....	11
Flat Casing Ranch with Sill Nosing Assembly.....	12
BMC Doors.....	14
Flat Casing Doors.....	16
Flat Casing Ranch Doors.....	17
<i>Lineal Lengths for Field Fabrication Kits.....</i>	<i>19</i>
<i>Weep Hole Drilling.....</i>	<i>20</i>
<i>Removal of Casing.....</i>	<i>20</i>

BMC Assembly

1. Test fit casing parts on flat surface with included corner keys without screws to verify assembly. See *figure 6*.

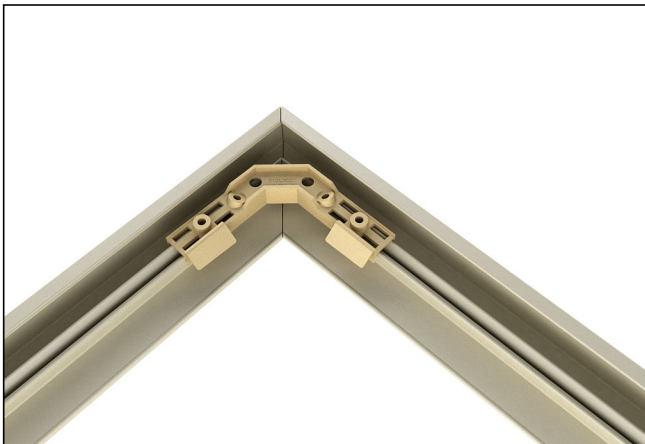

Figure 6

2. Shim under the interior edge before applying screws to corner key. See *figure 7*.

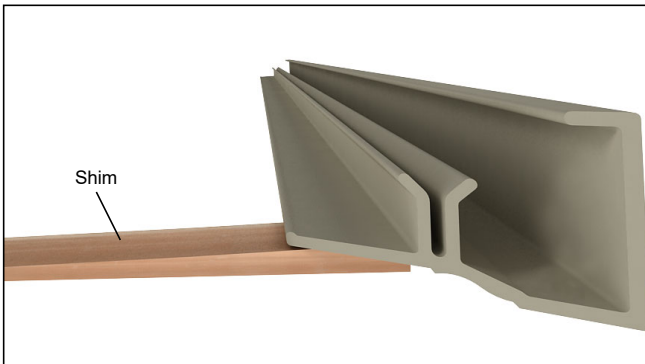

Figure 7

3. Fasten the corner key with included screws. First apply the outside 90° screws (1) followed by the two inside angled screws (2). Fasten until joints are tight. Over tightening may cause screw channel to strip out. See *figure 8*.

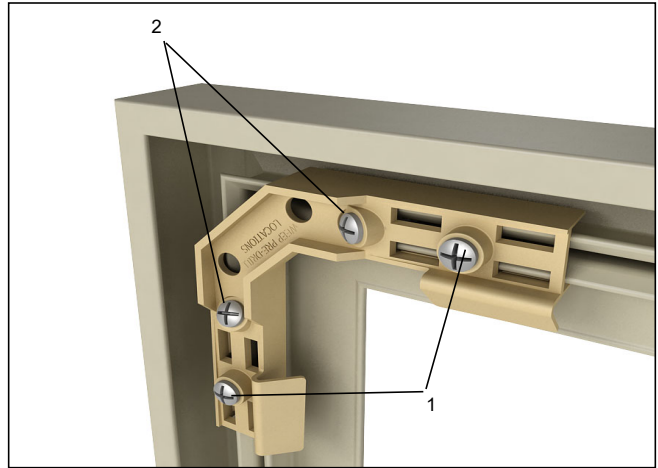

Figure 8

4. Place reticulated foam over the weep holes in sill piece. See *figure 9*.

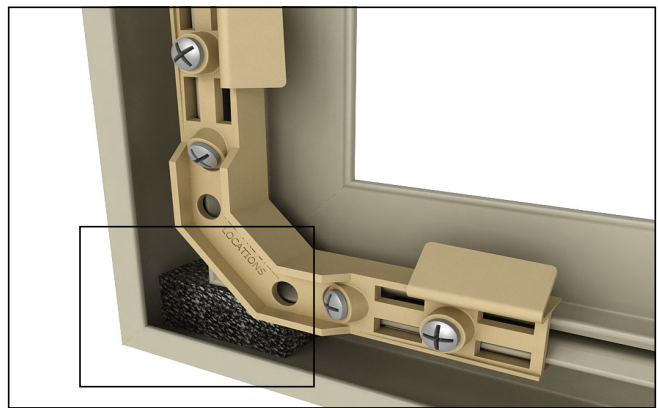

Figure 9

5. Apply a 3/16" (5) bead of clear grade NS class 25 sealant to the sill piece near the bump in the profile the length of the part, on the interior of the casing as shown in *figure 10*.

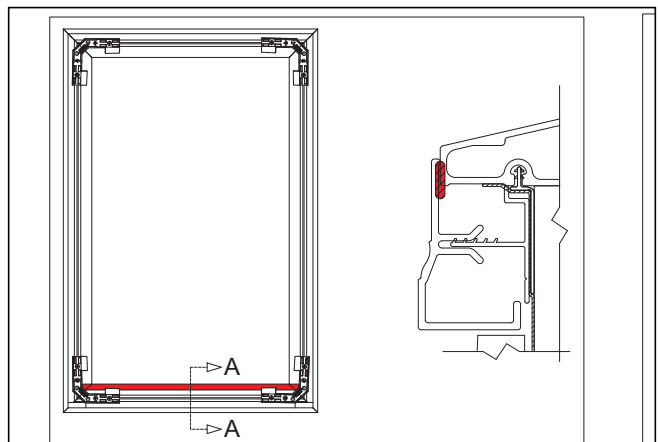

Figure 10

6. Press casing assembly onto connection bars by lining up all corners with the corner key alignment tabs. Press firmly (20-40 pounds of pressure) around the entire casing assembly until it is seated fully over frame. **Do not use excessive force, mallets, hammers, etc.** See figure 11.

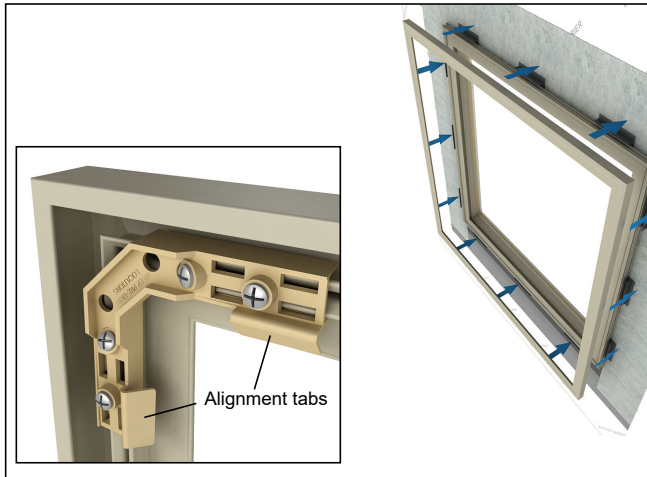

Figure 11

7. Seal casing with clear grade NS class 25 sealant at each jamb and the head jamb to siding or weather resistant barrier. (If required, backer rod may be used.) See figure 12.

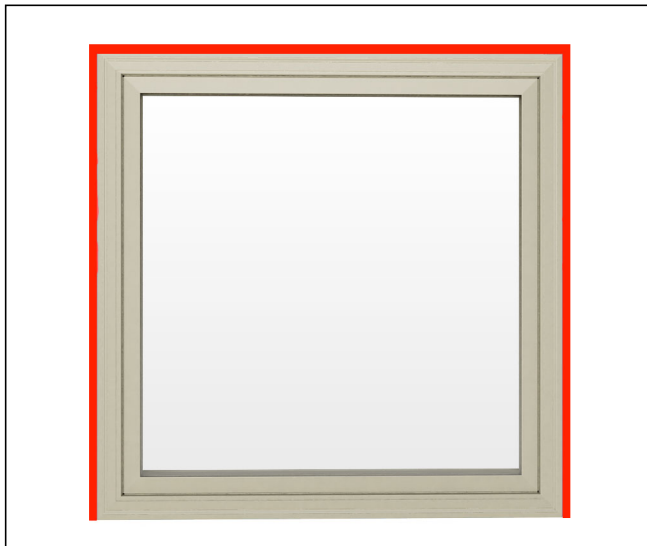

Figure 12

BMC with Sill Nosing Assembly

1. Modify sill end caps (both left hand and right hand) as shown in figure 13. Remove shaded area with utility scissors.

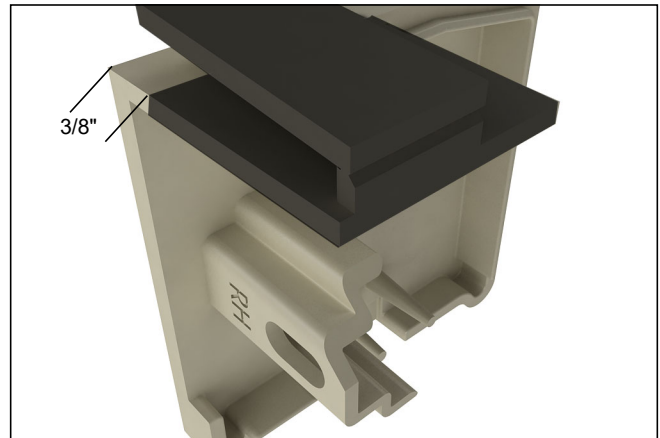

Figure 13

2. Test fit casing parts on flat surface with included corner keys without screws to verify assembly. See figure 14.

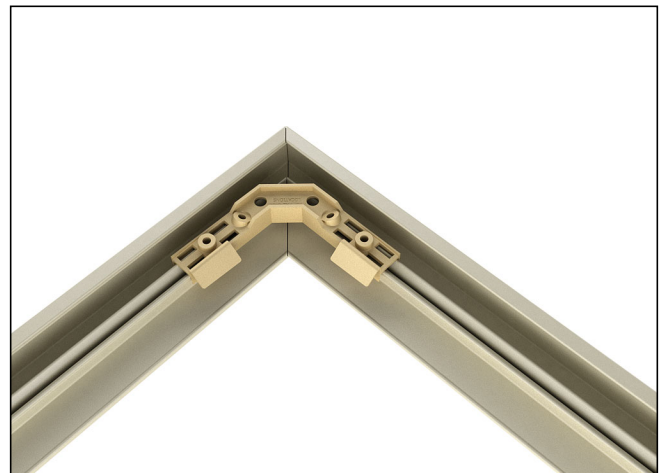

Figure 14

3. Assemble reticulated foam by pressing onto pegs making sure it covers weep hole. Attach end caps with supplied screws. See *figure 15*.

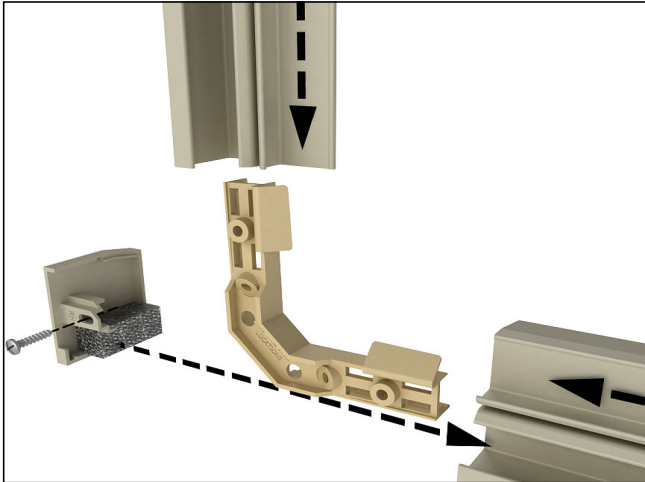

Figure 15

4. Shim under the interior edge before applying screws to corner key. See *figure 16*.

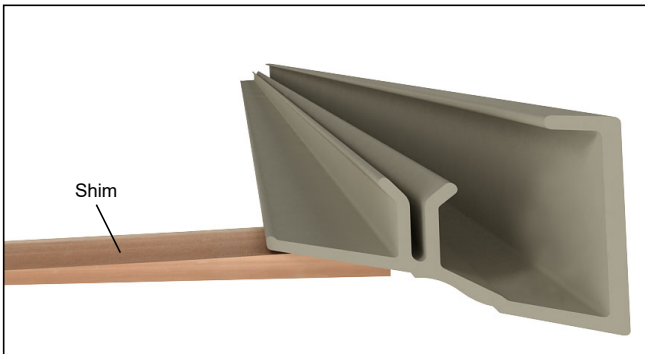

Figure 16

5. Fasten the corner key with included screws. First apply the outside 90° screws (1) followed by the two inside angled screws (2). Fasten until joints are tight. Over tightening may cause screw channel to strip out. See *figure 17*.

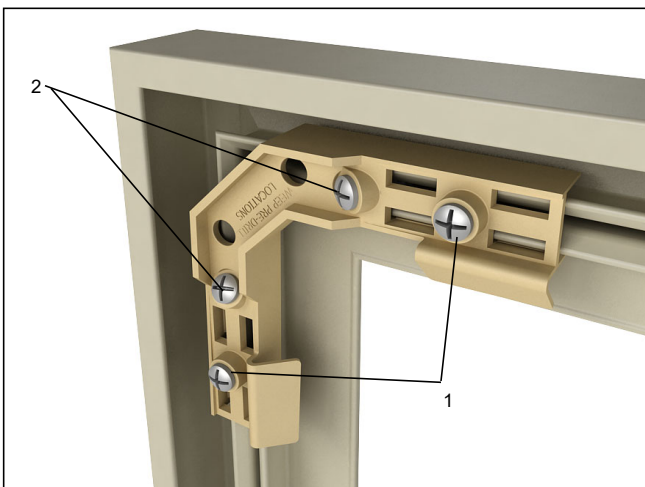

Figure 17

6. Press casing assembly onto connection bars by lining up all corners with the corner key alignment tabs. Press firmly (20-40 pounds of pressure) around the entire casing assembly until it is seated fully on frame. **Do not use excessive force, mallets, hammers, etc.** See *figure 18*.

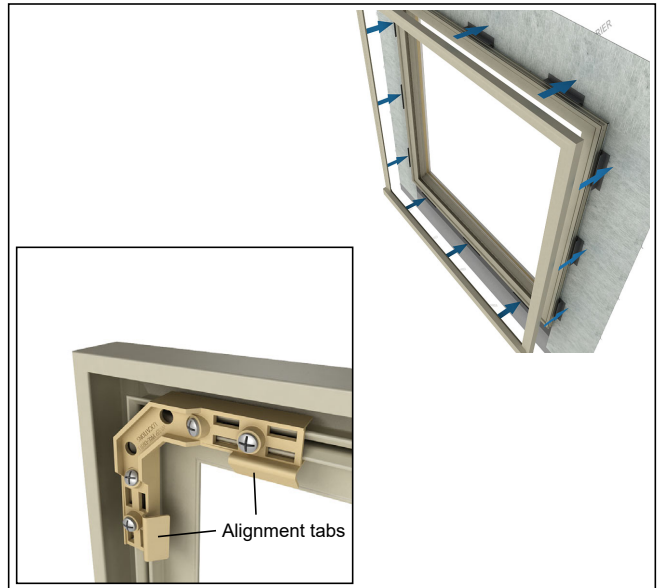

Figure 18

7. Apply a 3/16" (5) bead of clear class 25 grade NS sealant to the sill piece near the bump in the profile the length of the part on the interior of the casing as shown in *figure 19*.

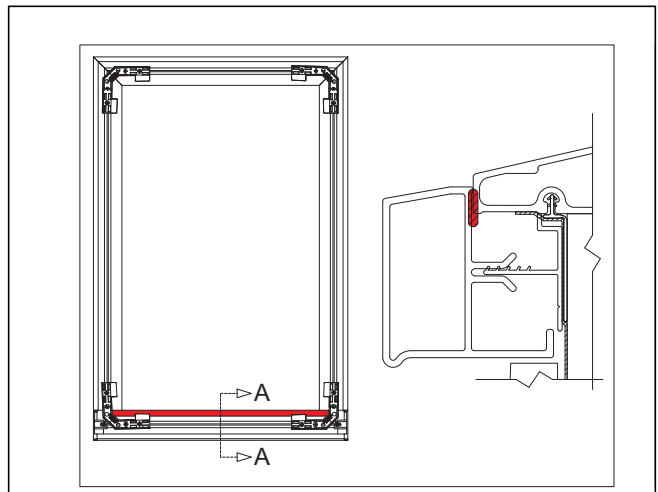

Figure 19



CAUTION

On Essential Sliding Window products, take care to keep sealant away from drain weeps in lower corners. Drain weeps must be kept clear to permit proper water performance and drainage.

8. Seal casing with clear grade NS class 25 sealant at each jamb and the head jamb to siding or weather resistant barrier. (If required, backer rod may be used.) See *figure 20*.

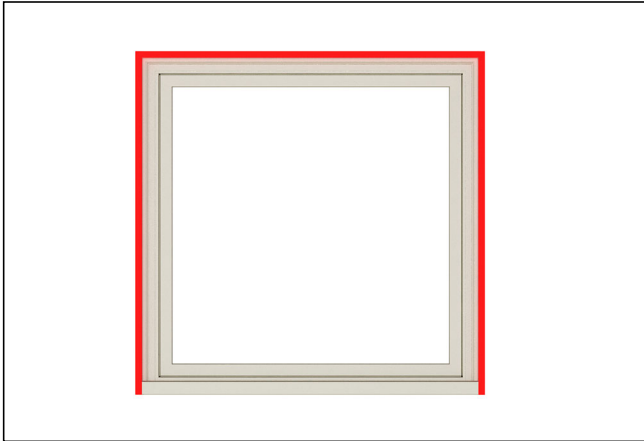

Figure 20

Flat Casing Assembly

1. Test fit casing parts on flat surface with included corner keys without screws to verify assembly. See *figure 21*.

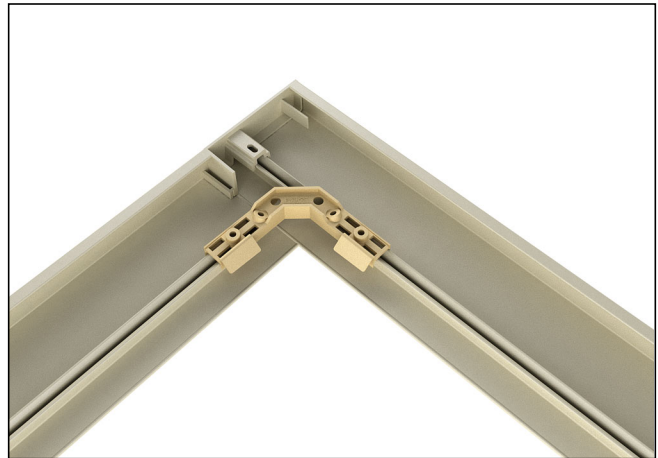

Figure 21

2. Secure end caps to casing with supplied screws. Align casing with tab on end caps and align all joints. See *figure 22*.

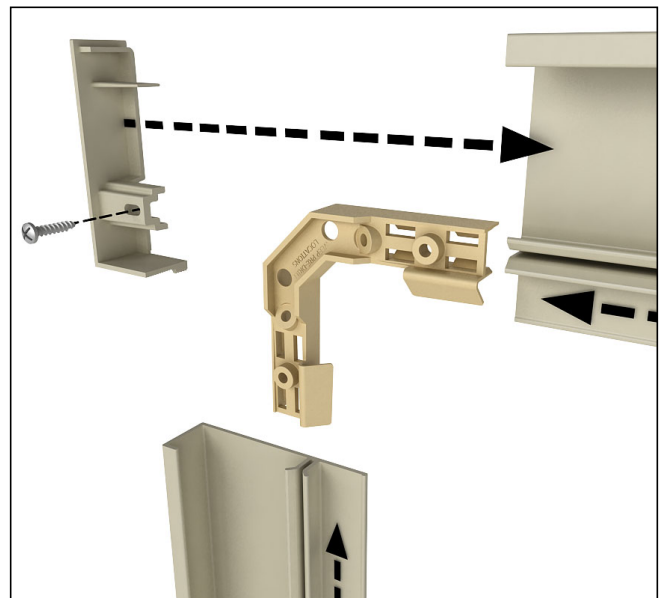

Figure 22

3. Fasten the corner key with included screws. First apply the outside 90° screws (1), followed by the two inside angled screws (2). Fasten until joints are tight. Over tightening may cause screw channel to strip out. See *figure 23*.

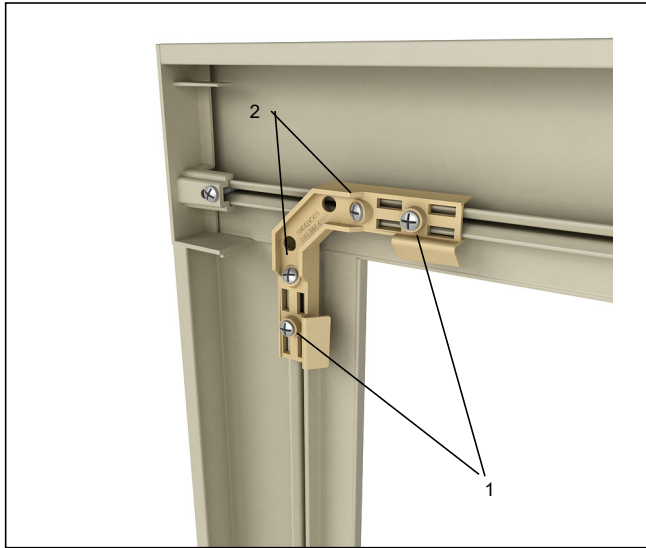

Figure 23

4. Place reticulated foam over the weep holes in sill piece. See *figure 24*.



Figure 24

5. Apply a 3/16" (5) bead of clear grade NS class 25 sealant to the sill piece near the bump in the profile the length of the part, on the interior of the casing as shown in *figure 25*.

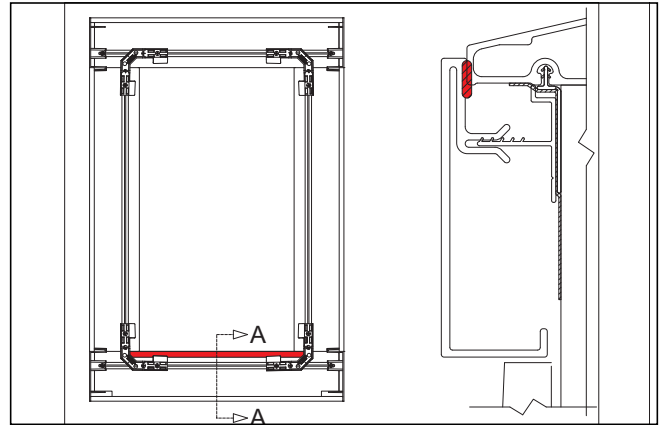

Figure 25



CAUTION

On Essential Sliding Window products, take care to keep sealant away from drain weeps in lower corners. Drain weeps must be kept clear to permit proper water performance and drainage.

6. Press casing assembly onto connection barbs by lining up all corners with the corner key alignment tabs. Press firmly (20-40 pounds of pressure) around the entire casing assembly until it is seated fully over frame. **Do not use excessive force, mallets, hammer, etc.** See *figure 26*.

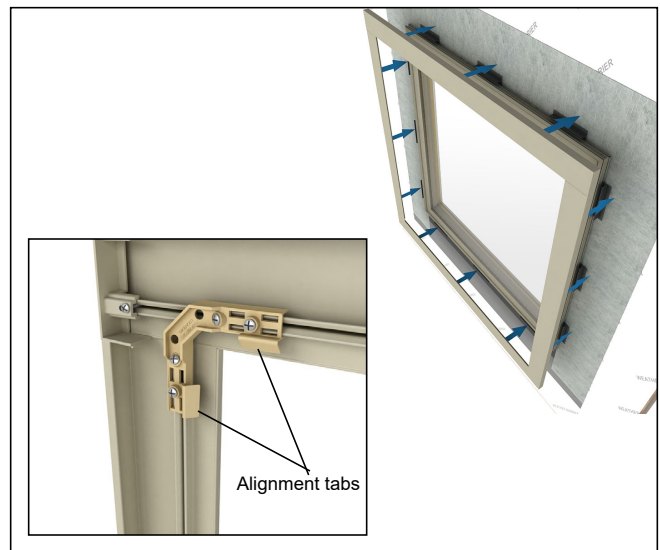

Figure 26

- Seal casing with clear grade NS class 25 sealant at each jamb and the head jamb to siding or weather resistant barrier. (If required, backer rod may be used.) See *figure 27*.

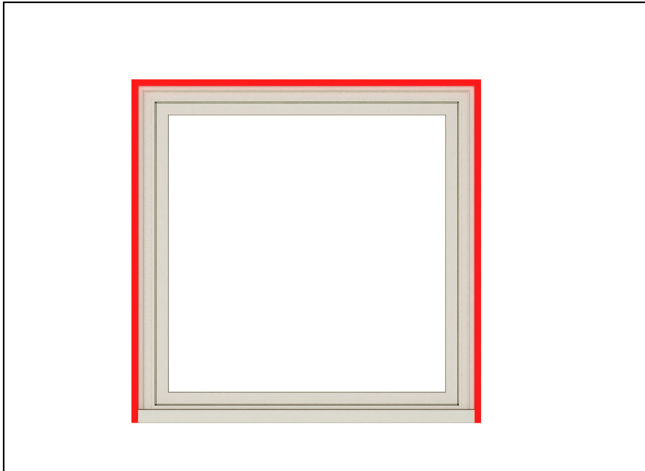

Figure 27

Flat Casing Ranch Assembly

- Break off shaded area on all four end caps. See *figure 28*.



Figure 28

- Test fit casing parts on flat surface with included corner keys without screws to verify assembly. See *figure 29*.



Figure 29

- Attach end caps to casing with supplied screws. See *figure 30*. Use tab to align jamb casing to header and sill pieces.

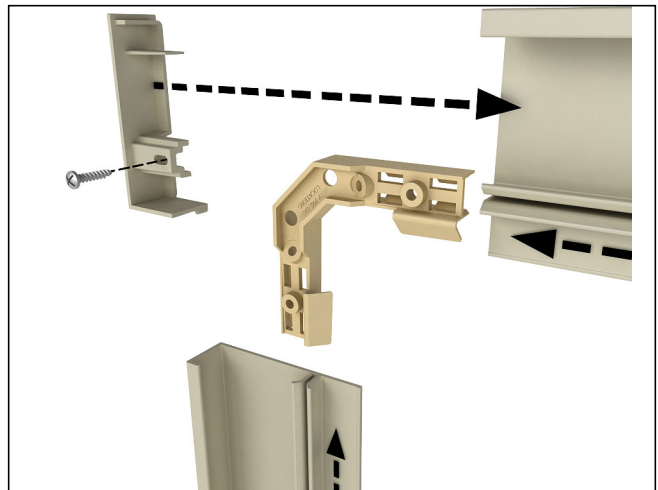

Figure 30

4. Fasten the corner key with included screws. First apply the outside 90° screws (1) followed by the two inside angled screws (2). Fasten until joints are tight. Over tightening may cause screw channel to strip out. See *figure 31*.

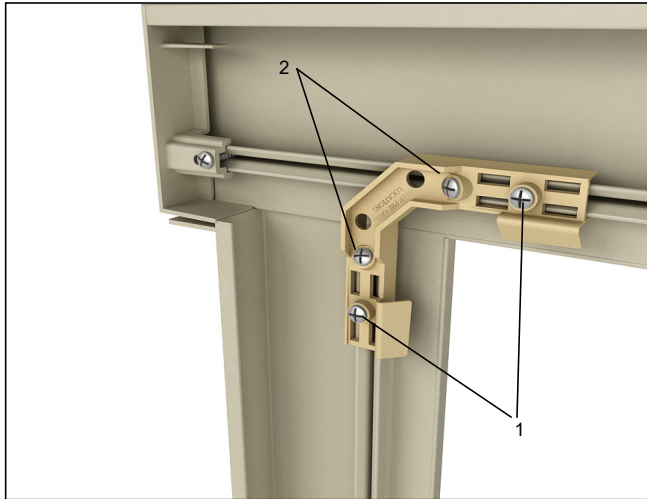

Figure 31

5. Place reticulated foam over the weep holes in sill piece. See *figure 32*.



Figure 32

6. Apply a 3/16" (5) bead of clear grade NS class 25 sealant to the sill piece near the bump in the profile the length of the part, on the interior of the casing as shown in *figure 33*.

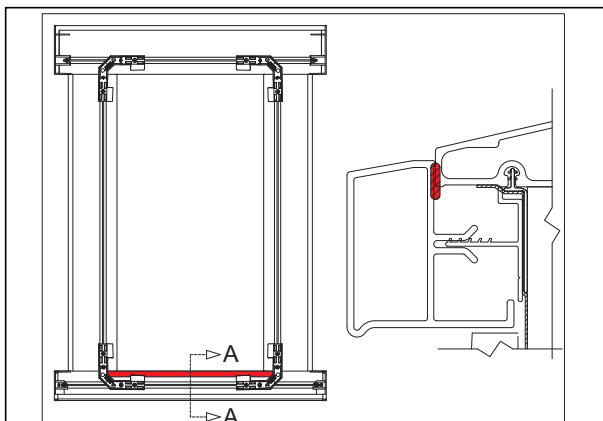

Figure 33



CAUTION

On Essential Sliding Window products, take care to keep sealant away from drain weeps in lower corners. Drain weeps must be kept clear to permit proper water performance and drainage.

7. Press casing assembly onto connection bars by lining up all corners with the corner key alignment tabs. Press firmly (20-40 pounds of pressure) around the entire casing assembly until it is seated fully on frame. **Do not use excessive force, mallets, hammers, etc.** See *figure 34*.

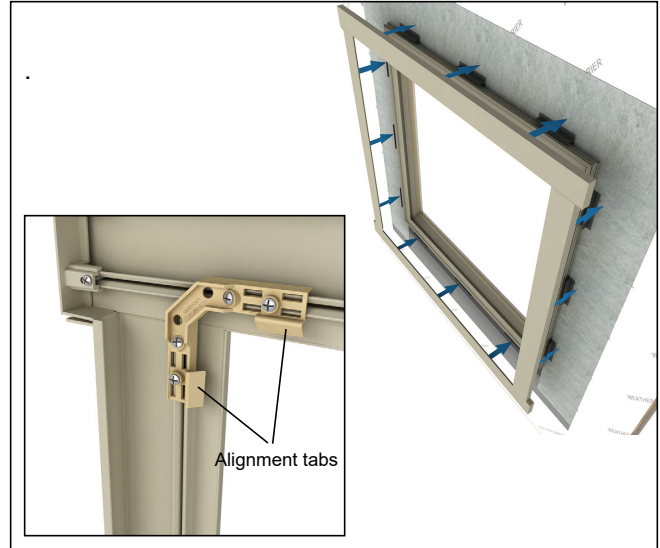

Figure 34

8. Seal casing at each jamb and head jamb to siding or weather resistant barrier. (If required, backer rod may be used.) See *figure 35*.

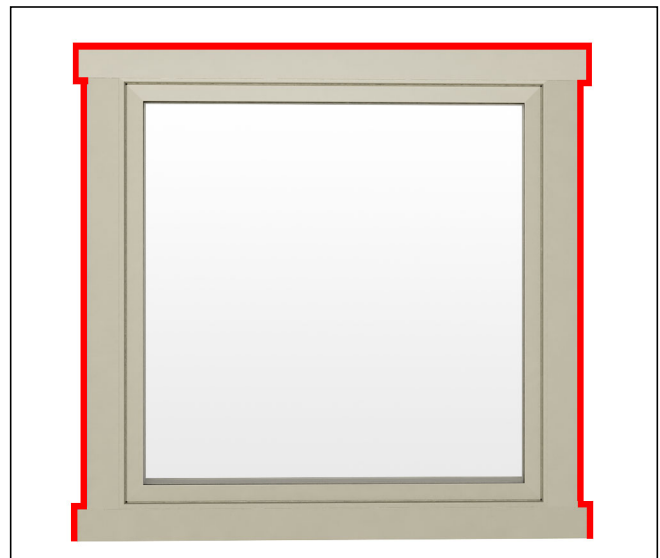

Figure 35

Flat Casing with Sill Nosing Assembly

1. Test fit casing parts on flat surface with included corner keys and end caps without screws to verify assembly. See *figure 36*.



Figure 36



Figure 38



Figure 37

2. Press reticulated foam onto pegs on sill end cap, making sure it covers the weep hole, and attach the sill nosing end caps to sill with supplied screws. Attach flat end caps to head jamb using supplied screws. Align casing with tab on end caps. See *figure 37*.
3. Fasten the corner key with included screws. First apply the outside 90° screws followed by the two inside angled screws. Fasten until joints are tight. Over tightening may cause screw channel to strip out. See *figure 38*.

4. Apply a 3/16" (5) bead of clear grade NS class 25 sealant to the sill piece near the bump in the profile the length of the part, on the interior of the casing as shown in *figure 39*.

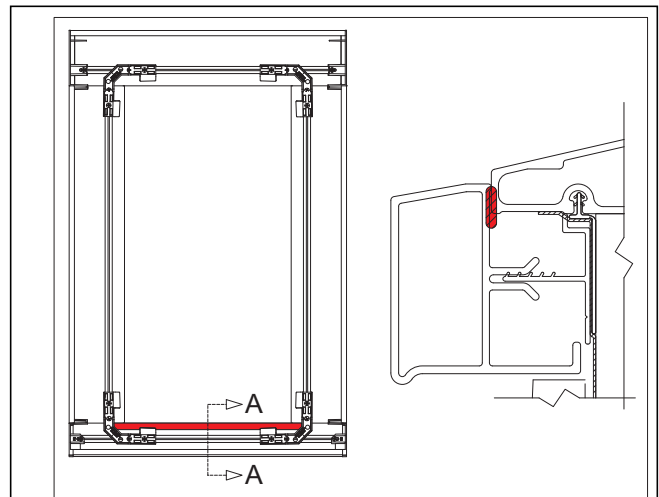

Figure 39



CAUTION

On Essential Sliding Window products, take care to keep sealant away from drain weeps in lower corners. Drain weeps must be kept clear to permit proper water performance and drainage.

5. Press casing assembly onto connection bars by lining up all corners with the corner key alignment tabs. Press firmly (20-40 pounds of pressure) around the entire casing assembly until it is seated fully over frame. **Do not use excessive force, mallets, hammers, etc.** See figure 40.

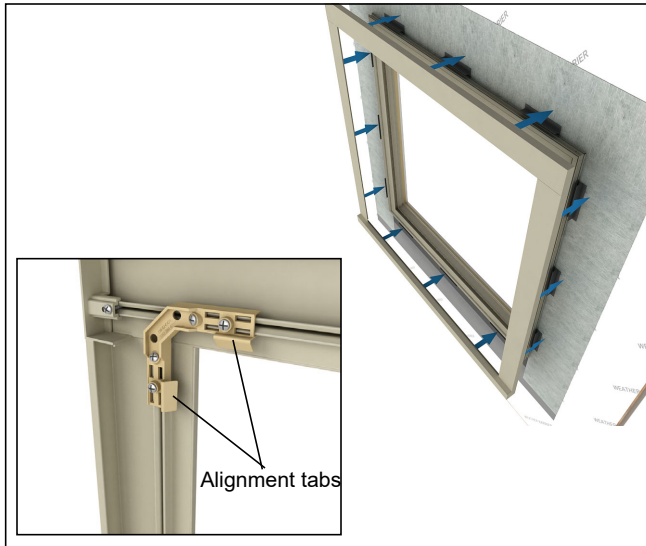

Figure 40

6. Seal casing with clear grade NS class 25 sealant at each jamb and the head jamb to siding or weather resistant barrier. (If required, backer rod may be used.) See figure 41.

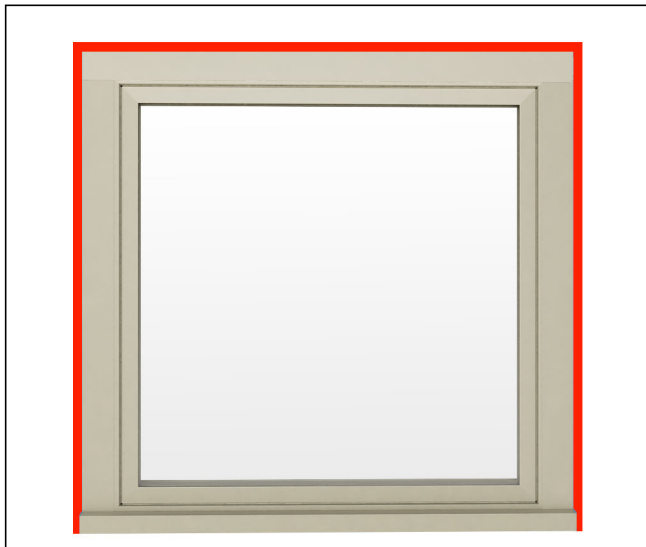

Figure 41

Flat Casing Ranch with Sill Nosing Assembly

1. Break off shaded area on both left hand and right hand sill end caps and flat end caps. See figure 42.

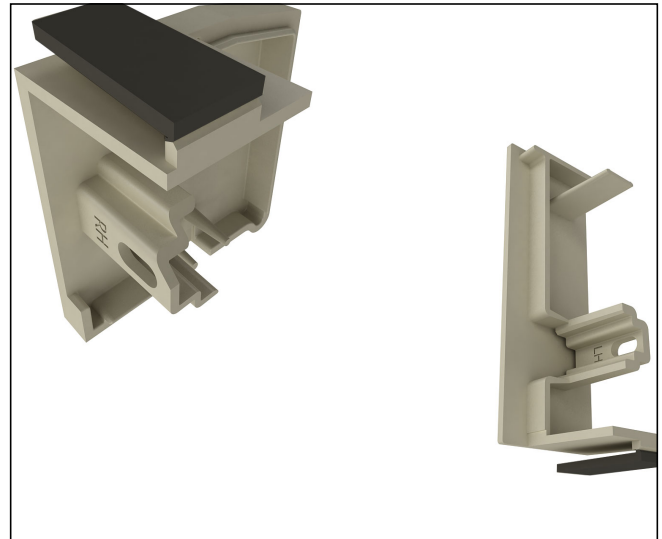

Figure 42

2. Test fit casing parts on flat surface with included corner keys without screws to verify assembly. See figure 43 (header) and figure 44 (sill).

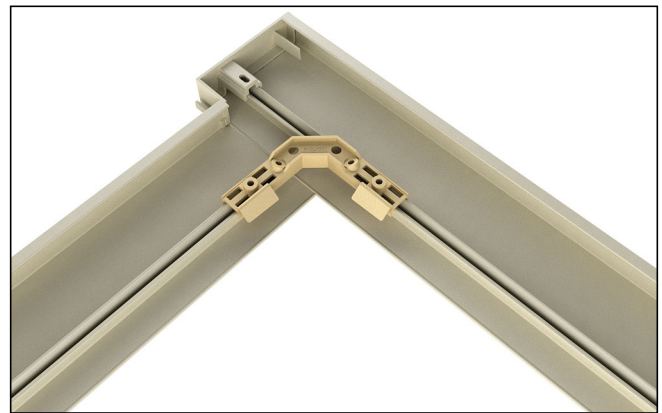

Figure 43

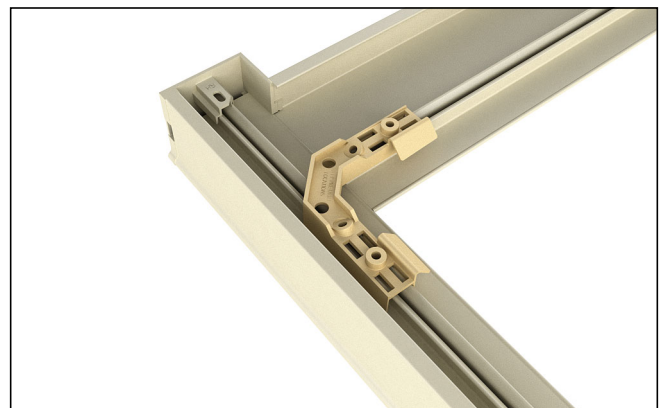

Figure 44

3. Press reticulated foam onto pegs on sill end cap, making sure it covers the weep hole, and attach the sill nosing end caps to sill with supplied screws. Attach flat end caps to head jamb using supplied screws. Align casing with tab on end caps. See *figure 45*.

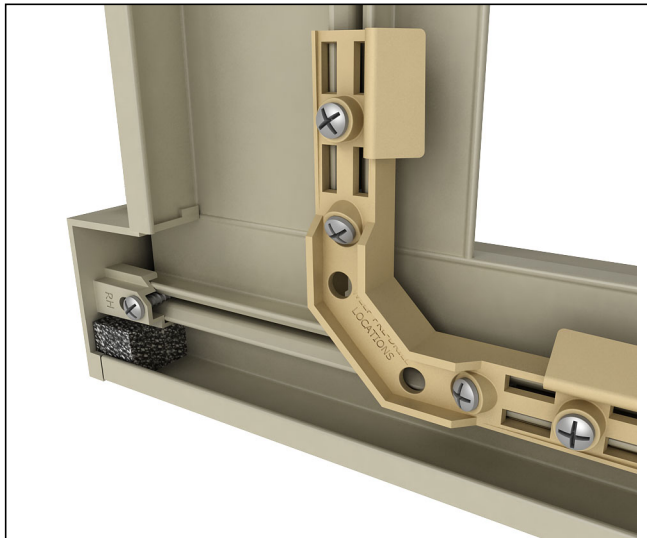

Figure 45

4. Fasten the corner key with included screws. First apply the outside 90° screws (1) followed by the two inside angled screws (2). Fasten until joints are tight. Over tightening may cause screw channel to strip out. See *figure 46*.

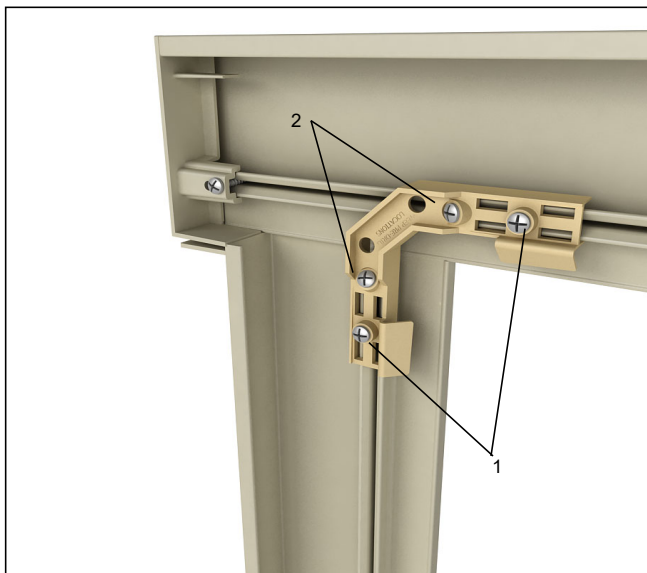

Figure 46

5. Apply a 3/16" (5) bead of clear grade NS class 25 sealant of the sill piece near the bump in the profile the length of the part, on the interior of the casing as shown in *figure 47*.

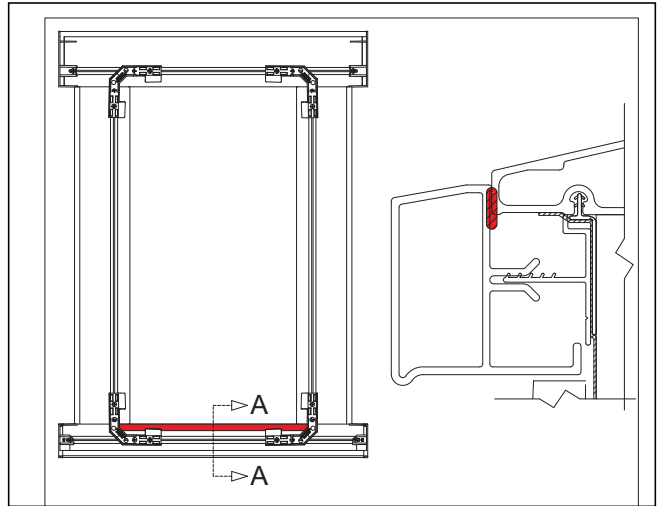

Figure 47



CAUTION

On Essential Sliding Window products, take care to keep sealant away from drain weeps in lower corners. Drain weeps must be kept clear to permit proper water performance and drainage.

6. Press casing assembly onto connection bars by lining up all corners with the corner key alignment tabs. Press firmly (20-40 pounds of pressure) around the entire casing assembly until it is seated fully over frame. **Do not use excessive force, mallets, hammers, etc.** See *figure 48*.

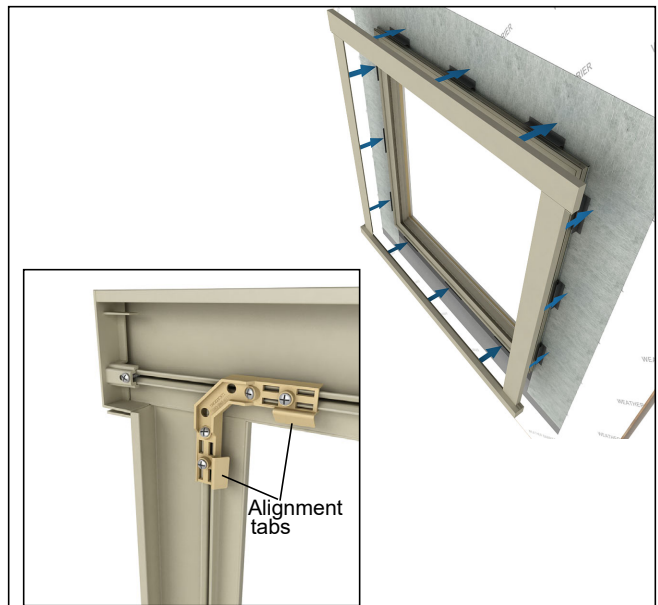

Figure 48

7. Seal casing with clear grade NS class 25 sealant at each jamb to siding or weather resistant barrier. (If required, backer rod may be used.) See *figure 49*.

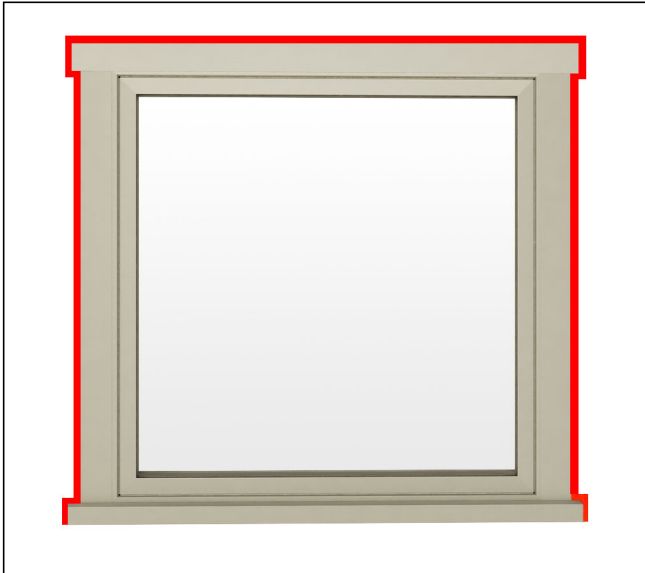

Figure 49

BMC Doors

1. Test fit casing parts on flat surface with included corner keys without screws to verify assembly. See *figure 50*.

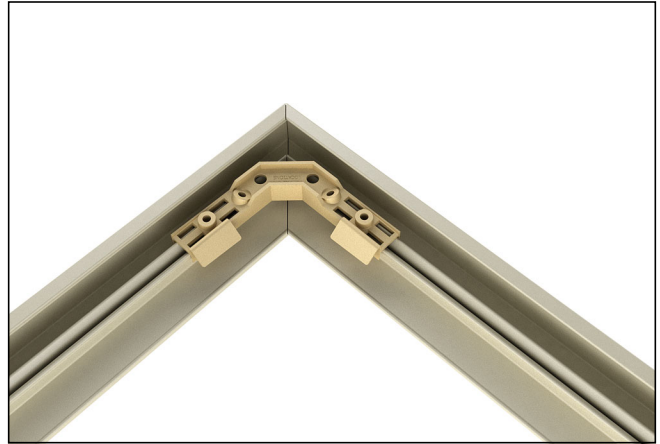

Figure 50

2. Shim under the inside edge of BMC before applying screws to corner key. See *figure 51*.

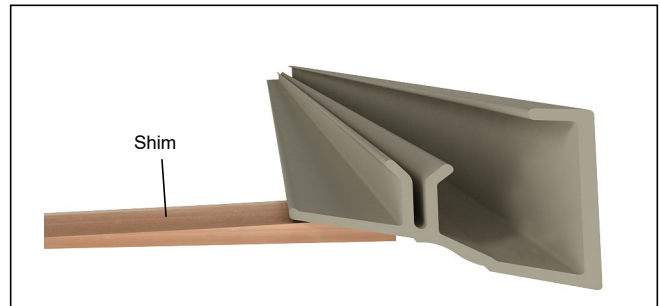

Figure 51

3. Fasten the corner key with included screws. First apply the outside 90° screws (1) followed by the two inside angled screws (2). Fasten until joints are tight. Over tightening may cause screw channel to strip out. See *figure 52*.

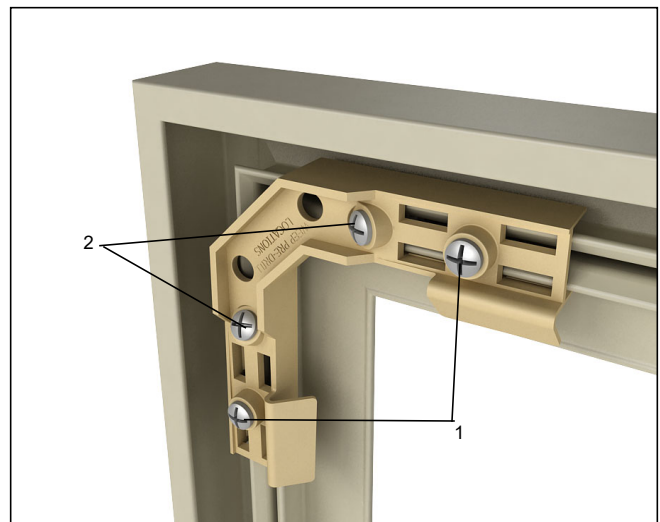

Figure 52

4. Insert foam plug in the bottom of the BMC jamb pieces. See *figure 53*.



Figure 53

5. Press casing assembly onto connection bars by lining up all corners with the corner key alignment tabs. Press firmly (20-40 pounds of pressure) around the entire casing assembly until it is seated fully over door. **Do not use excessive force, mallets, hammers, etc.** See *figure 54*.

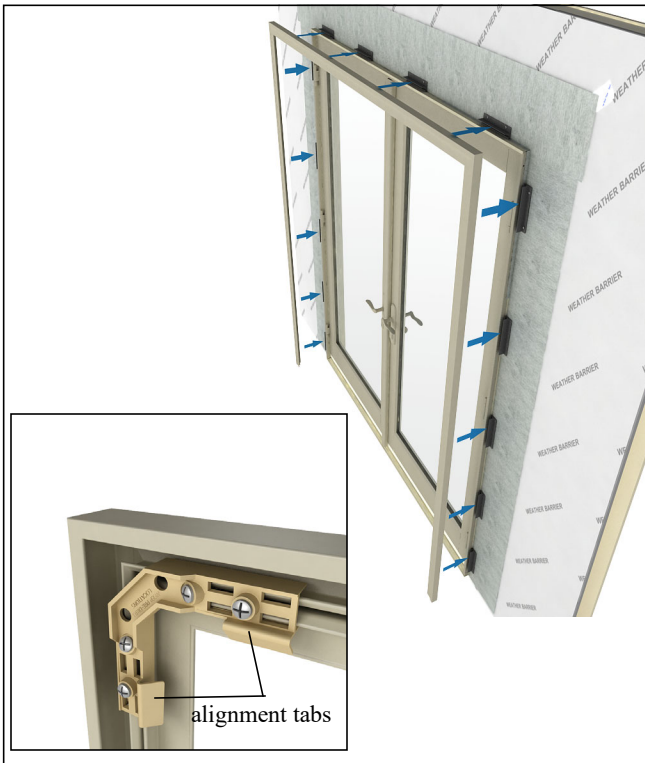

Figure 54

6. Seal casing with clear grade NS class 25 sealant at each jamb and the head jamb to siding or weather resistant barrier. (If required, backer rod may be used.) See *figure 55*.



Figure 55

Flat Casing Doors

1. Modify one left hand and one right hand end caps by removing shaded area with utility scissors to fit into the bottom of the jamb pieces. Remaining end caps will not be modified. See *figure 56*.

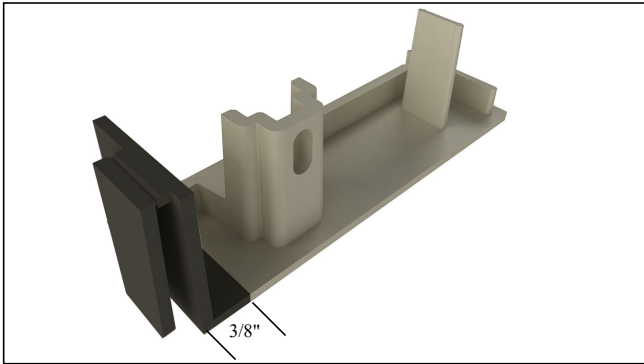

Figure 56

2. Test fit casing parts on flat surface with included corner keys without screws to verify assembly. See *figure 57*.



Figure 57

3. Attach modified end caps with supplied screws to the bottom of the jamb pieces. See *figure 58*.

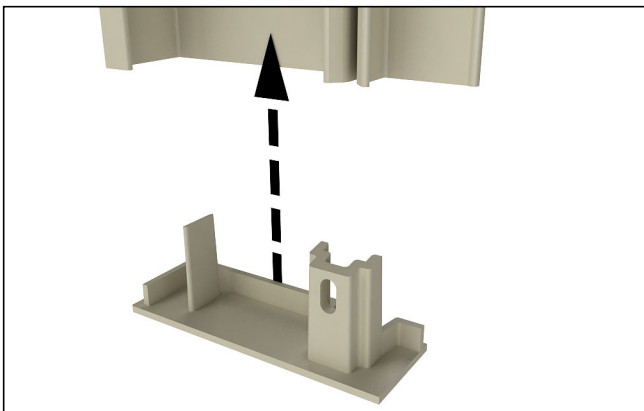

Figure 58

4. Attach end caps to header casing with supplied screws. Align casing with tab on end caps. See *figure 59*.

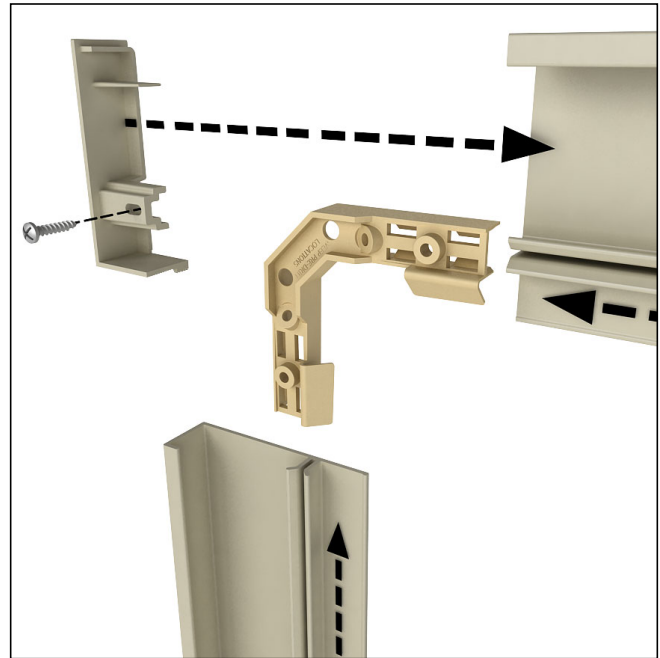

Figure 59

5. Align casing with tab on end caps. Fasten the corner key with included screws. First apply the outside 90° screws (1) followed by the two inside angled screws (2). Fasten until joints are tight. Over tightening may cause screw channel to strip out. See *figure 60*.

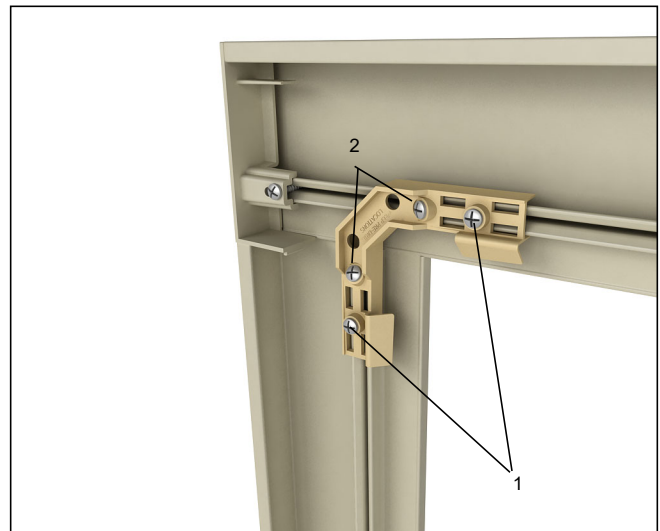

Figure 60

6. Press casing assembly onto connection bars by lining up all corners with the corner key alignment tabs. Press firmly (20-40 pounds of pressure) around the entire casing assembly until it is seated fully over door. **Do not use excessive force, mallets, hammers, etc.** See figure 61.

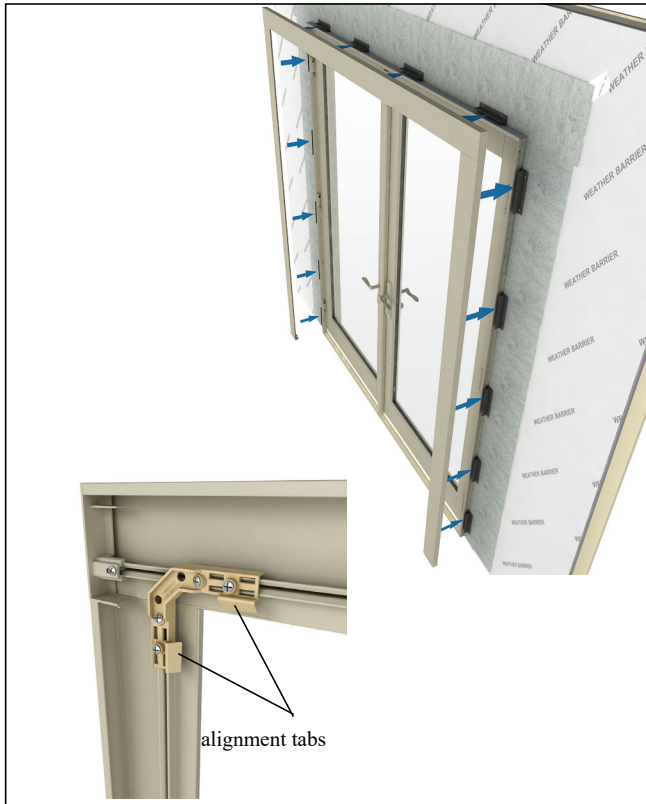

Figure 61

7. Seal casing with clear grade NS class 25 sealant at each jamb and the head jamb to siding or weather resistant barrier. (If required, backer rod may be used.) See figure 62.

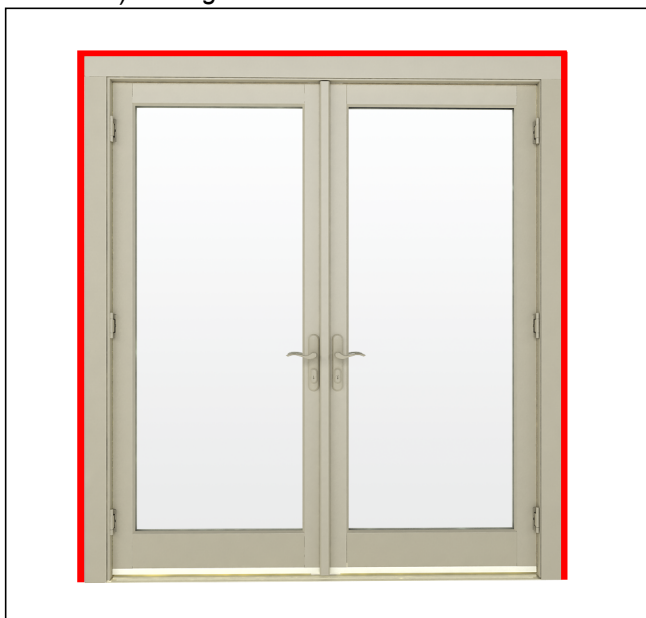

Figure 62

Flat Casing Ranch Doors

1. Modify one left hand and one right hand end cap by removing shaded area with utility scissors to fit into the bottom of the jamb pieces. See figure 63A. Break off tab of shaded area on one left hand and one right hand end caps. See figure 63B.

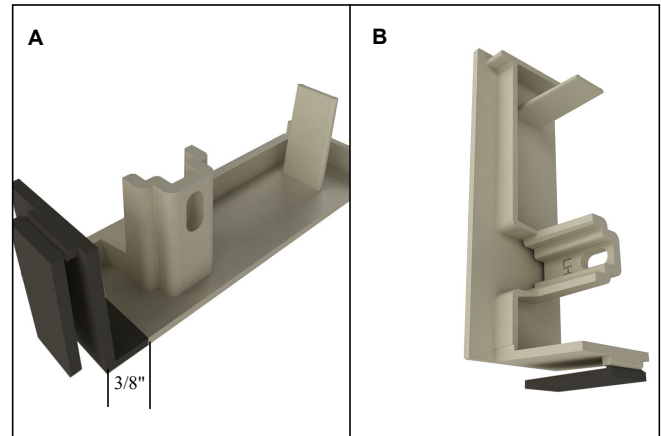

Figure 63

2. Test fit casing parts on flat surface with included corner keys without screws to verify assembly. See figure 64.



Figure 64

3. Attach a modified end caps with supplied screws to bottom of jamb pieces. See *figure 65*.

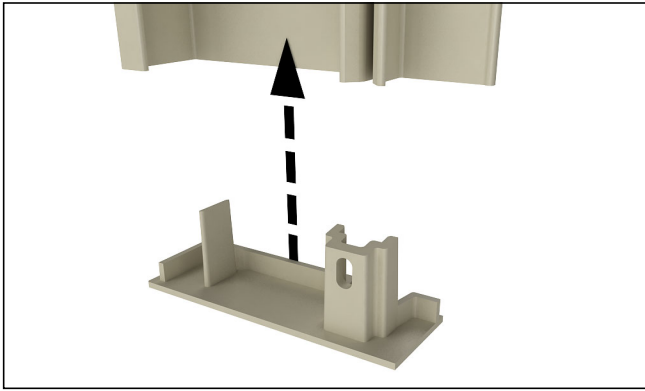

Figure 65

4. Attach end caps to head jamb pieces with supplied screws. See *figure 66*.

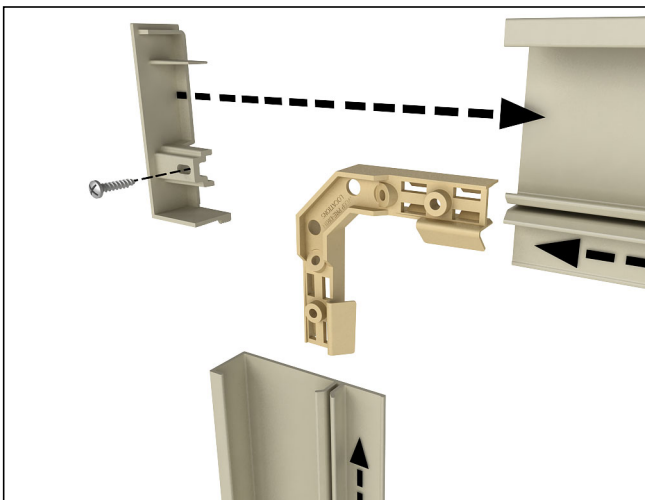

Figure 66

5. Use tab to align jamb casing to header and sill piece. Fasten the corner key with included screws. First apply the outside 90° screws (1) followed by the two inside angled screws (2). Fasten until joints are tight. Over tightening may cause screw channel to strip out. See *figure 67*.

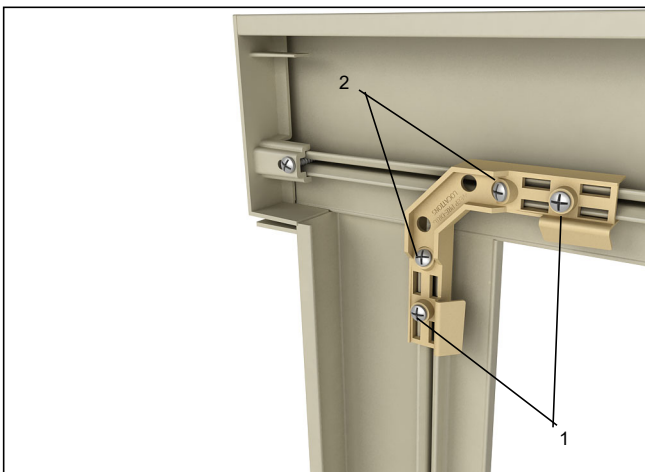

Figure 67

6. Press casing assembly onto connection bars by lining up all corners with the corner key alignment tabs. Press firmly (20-40 pounds of pressure) around the entire casing assembly until it is seated fully over frame. **Do not use excessive force, mallets, hammers, etc.** See *figure 68*.

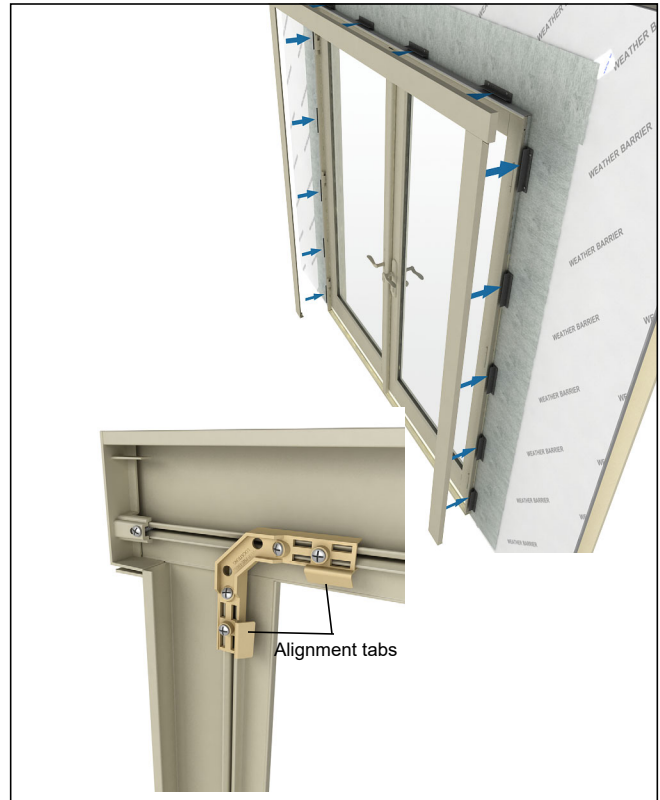

Figure 68

7. Seal casing with clear grade NS class 25 sealant at each jamb and the head jamb to siding or weather resistant barrier. (If required, backer rod may be used.) See *figure 69*.



Figure 69

Field Fabrication Kits for Linear Lengths

Lineal lengths will need to be cut, please follow chart on pages 21 (Essential) and 23 (Elevate) for correct conversion for specific configuration.

1. For cutting Ultrex lineal casing parts, use a continuous rim diamond blade. Ensure to keep parts square and fixed. Shim under the BMC with a 7/16" (22) thick block to keep casing square. See *figure 70*.

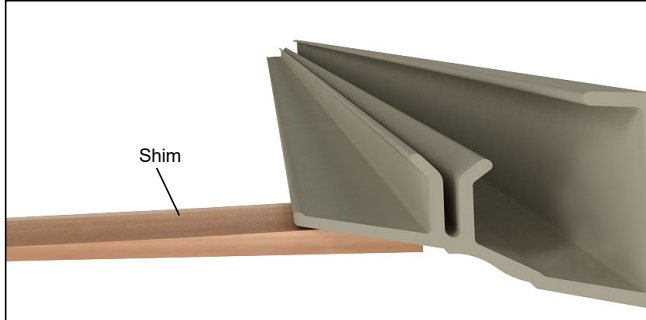

Figure 70

Weep Hole drilling

Pre-cut kits have weep holes drilled.

Configurations that need weep holes drilled:

- BMC
- 3 1/2" Flat Casing
- 3 1/2" Flat Casing Ranch style.

1. Use the corner key as the weep hole location jig (*figure 71A*), drill weep hole using 1/4" drill bit as shown in *figure 71B*. Weep hole placement will be drilled towards exterior of casing.

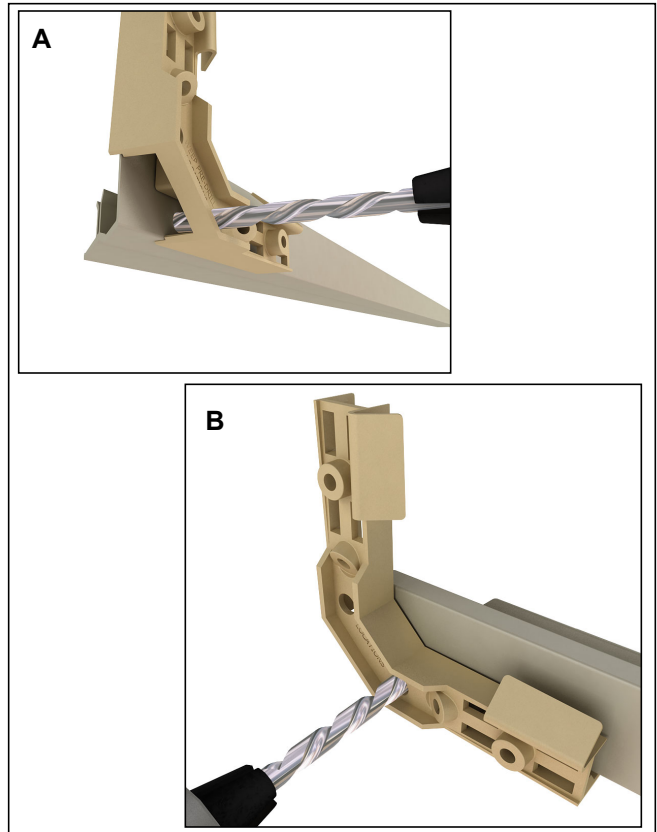

Figure 71

Removal of Casing

1. For exterior trim removal, cut silicone between each jamb, sill, and head jamb. See *figure 72*.

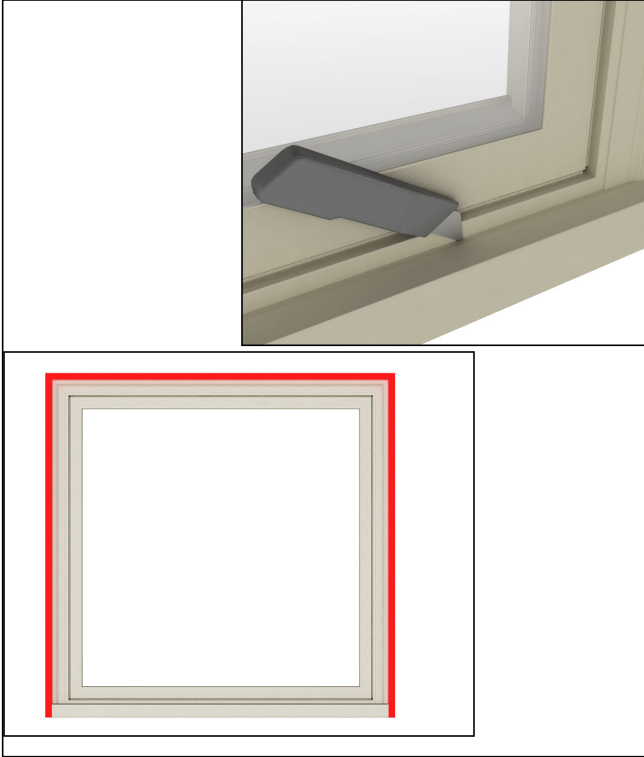

Figure 72

2. Use pry bar at the interior of the trim opening and pry away from unit. Use a protective barrier between the pry bar and unit to protect from denting or damaging casing and/or unit. See *figure 73*.



Figure 73

3. Work around the casing until all connection bars have released the casing and remove casing surround.

Outside Measurement Conversion for Exterior Casing (Essential)

Frame Outside Measurement (Essential) to Exterior Casing Individual Part Finished Overall Length		
Essential Windows		
Exterior Casing Configuration	Part	ES Conversion
BMC (all four sides)	Header & Sill 45° end cuts	+ 3 11/16"
	Jambs 45° end cuts	+ 3 11/16"
BMC w/ Sill Nosing	Header 45° end cuts	+ 3 11/16"
	Sill 90° end cuts	+ 3 3/16"
	Jambs 45° end cuts on header end 90° end cuts on sill end	+ 1 11/16"
3.5" Flat Casing (all four sides)	Header & Sill 90° end cuts	+ 6 17/32"
	Jambs 90° end cuts	- 5/16"
3.5" Flat Casing w/ Sill Nosing	Header 90° end cuts	+ 6 17/32"
	Sill 90° end cuts	+ 6 3/16"
	Jambs 90° end cuts	- 5/16"
3.5" Flat Casing - Ranch Style	Header & Sill 90° end cuts	+ 8 17/32"
	Jambs 90° end cuts	- 5/16"
3.5" Flat Casing - Ranch Style w/ Sill Nosing	Header 90° end cuts	+ 8 17/32"
	Sill 90° end cuts	+ 8 3/16"
	Jambs 90° end cuts	- 5/16"
Essential Doors		
Exterior Casing Configuration	Part	ES Conversion
BMC	Header 45° end cuts	+ 3 11/16"
	Jambs 45° end cuts on header end 90° end cuts on sill end	+ 1 27/32"
3.5" Flat Casing	Header 90° end cuts	+ 6 17/32"
	Jambs 90° end cuts	- 1/4"
3.5" Flat Casing - Ranch Style	Header 90° end cuts	+ 8 17/32"
	Jambs 90° end cuts	- 1/4"

Outside Measurement Conversion for Exterior Casing (Essential)

Frame Outside Measurement (Essential) to Exterior Casing Outside Measurement Conversion		
Essential Windows		
Exterior Casing Configuration	Width	Height
BMC (all four sides)	+ 3 11/16"	+ 3 11/16"
BMC w/ Sill Nosing	+ 3 11/16"	+ 3 11/16"
3.5" Flat Casing (all four sides)	+6 11/16"	+6 11/16"
3.5" Flat Casing w/ Sill Nosing	+6 11/16"	+5 3/16"
3.5" Flat Casing — Ranch Style	+8 11/16"*	+6 11/16"
3.5" Flat Casing — Ranch Style w/ Sill Nosing	+8 11/16"*	+5 3/16"
Essential Doors		
Exterior Casing Configuration	Width	Height
BMC (header & jambs)	+3 11/16"	+1 13/16"
3.5" Flat Casing (header & jambs)	+6 11/16"	+3 11/32"
3.5 Flat Casing — Ranch Style (header & jambs)	+8 11/16"*	+3 11/32"

Outside Measurement Conversion for Exterior Casing (Elevate)

Frame Outside Measurement (Elevate) to Exterior Casing Individual Part Finished Overall Length		
Elevate Windows		
Exterior Casing Configuration	Part	EL Conversion
BMC (all four sides)	Header & Sill 45° end cuts	+ 3 3/8"
	Jambs 45° end cuts	+ 3 3/8"
BMC w/ Sill Nosing	Header 45° end cuts	+ 3 3/8"
	Sill 90° end cuts	+ 2 7/8"
	Jambs 45° end cuts on header end 90° end cuts on sill end	+ 1 3/8"
3.5" Flat Casing (all four sides)	Header & Sill 90° end cuts	+ 6 7/32"
	Jambs 90° end cuts	- 5/8"
3.5" Flat Casing w/ Sill Nosing	Header 90° end cuts	+ 6 7/32"
	Sill 90° end cuts	+ 5 7/8"
	Jambs 90° end cuts	- 5/8"
3.5" Flat Casing - Ranch Style	Header & Sill 90° end cuts	+ 8 7/32"
	Jambs 90° end cuts	- 5/8"
3.5" Flat Casing - Ranch Style w/ Sill Nosing	Header 90° end cuts	+ 8 7/32"
	Sill 90° end cuts	+ 7 7/8"
	Jambs 90° end cuts	- 5/8"
Elevate Doors		
Exterior Casing Configuration	Part	EL Conversion
BMC	Header 45° end cuts	+ 3 3/8"
	Jambs 45° end cuts on header end 90° end cuts on sill end	+ 1 11/16"
3.5" Flat Casing	Header 90° end cuts	+ 6 7/32"
	Jambs 90° end cuts	- 3/8"
3.5" Flat Casing - Ranch Style	Header 90° end cuts	+ 8 7/32"
	Jambs 90° end cuts	- 3/8"

Outside Measurement Conversion for Exterior Casing (Elevate)

Frame Outside Measurement (Elevate) to Exterior Casing Outside Measurement Conversion		
Elevate Windows		
Exterior Casing Configuration	Width	Height
BMC (all four sides)	+ 3 3/8"	+ 3 3/8"
BMC w/ Sill Nosing	+ 3 3/8"	+ 3 3/8"
3.5" Flat Casing (all four sides)	+ 6 3/8"	+ 6 3/8"
3.5" Flat Casing w/ Sill Nosing	+ 6 3/8"	+ 4 7/8"
3.5" Flat Casing — Ranch Style	+ 8 3/8"*	+ 6 3/8"
3.5" Flat Casing — Ranch Style w/ Sill Nosing	+ 8 3/8"*	+ 4 7/8"
Elevate Doors		
Exterior Casing Configuration	Width	Height
BMC (header & jambs)	+ 3 3/8"	+ 1 11/16"
3.5" Flat Casing (header & jambs)	+ 6 3/8"	+ 3 3/16"
3.5 Flat Casing — Ranch Style (header & jambs)	+ 8 3/8"*	+ 3 3/16"