

Elevate Aluminum Direct Glaze Round Tops

- Unit Features 1
- Sizing Guidelines / Measurement Conversions 3
- Certified Frame-to-Frame Mulling Guidelines 4
- Certified 1/2" MRF Mulling Guidelines 5
- Grilles-Between-the-Glass 6
- Available Divided Lite Patterns 8
- Section Details - Casement 12
- Section Details - Double Hung/Door 13
- Section Details - Mullions 14
- Section Details - 1/2" MRF Mullions 15
- Installation Suggestion - Brick Veneer with Steel Frame Construction 16

Unit Features

For applicable certification and code information, refer to the Introduction and Product Performance chapter.

Abbreviations

Elevate Aluminum Direct Glaze Round Top: ELALDG RT

Elevate Aluminum Direct Glaze Round Top Casement: ELALDG RT CA

Elevate Aluminum Direct Glaze Round Top Door Transom: ELALDG RT DRTR

Elevate Aluminum Direct Glaze Round Top Double Hung: ELALDG RT DH

Frame:

- The frame exterior is made of extruded aluminum cladding meeting or exceeding requirements. Available colors: Stone White, Pebble Gray, Bronze, Cashmere, Gunmetal, or Ebony.
- The interior is non finger-jointed pine, kiln dried to a moisture content of 6-12% at time of fabrication. Water-repellent, preservative treated.
- Interior wood is available as Pine bare wood or factory applied White, Clear, or Designer Black interior finishes.
- Frame width is 4 9/16" (116).
- Non finger-jointed pine interior stop is applied to all units.

Jamb Extension:

- Extension Thickness: 9/16" (14)
- Multiple depths available from 1/8" (3), 1/4"(6), and depths varying between 1/2"(13) and 4"(102) at 1/16" (2) increments
- Maximum jamb depth is 8 9/16". (217)
- 6 13/16" (173) or 6 13/16" (173) jamb extension - factory-applied
- All other jamb depth options are available shipped loose.
- Material: Bare Pine
- Option: factory applied white, designer black and clear lacquer interior finish

Installation:

- Folding nailing fin.
- Optional installation brackets available for round tops without nailing fin intended for masonry application.

Glazing:

- All units are manufactured with a glass thickness varying from 11/16 (17mm) to 1" (25mm) IG with Low E2, E3, E3/ERS, or E1 coatings including argon gas or air fill.
- Tempered glass and/or obscure, and California Fire glass (annealed exterior and tempered interior glazing configuration) glass are available as an option.
- Clear (uncoated) glass available with air fill only.
- STC/OITC values are available for 3.1 mm thickness glass.
 - Optional 3.1/4.7 STC/OITC upgrade glass is available. See Product Performance chapter for STC and OITC ratings.
- The glazing seal is a silicone bedding on the exterior surface with glazing tape on the interior.
- Decorative glass options include glue chip, rain, reed, narrow reed, frost, and tinted (bronze, gray or green). Decorative glass is not available with Low E1, Low E3/ERS or STC/OITC Upgrade options.

Unit Features**Interior / Exterior Simulated Divided Lites (SDL):**

- Interior bar: 7/8" (22) wide bars. Pine bare wood or factory applied White, Clear, or Designer Black finishes to match the interior.
- Exterior straight bar: 7/8" (22) wide bars Ultrex, finish to match exterior
- Exterior radius bar: ABS Hi, HDT 7/8" (22) wide bars. Available in sunburst patterns with an open hub. Finish to match exterior.
- SDL with spacer bar available on standard sunburst patterns with an open hub only. SDL with spacer bar is not available on solid or closed hub patterns or with tinted glass. Glue chip and decorative glass pattern requires tempered glass. SDL unavailable with rain, reed and narrow reed patterns.

Grilles-Between-the-Glass (GBG):

- GBGs are manufactured from aluminum in an 23/32" (18) contoured profile placed between two panes of glass, available in standard sunburst patterns with a solid hub. Exterior color: Stone White, Pebble Gray, Bronze, Cashmere, Gunmetal, or Ebony. Interior Colors: White, Bronze, or Ebony. Not available with tinted glass.

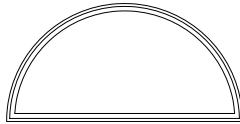
Round Tops

RT1

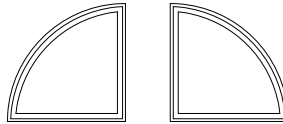

RT7 and RT8

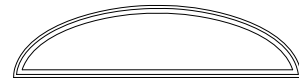

RT29

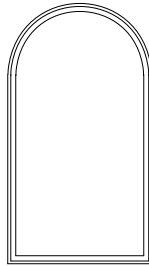

RT2

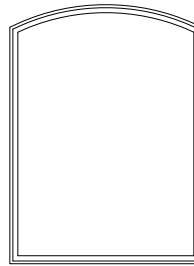

RT6

NOTE: Drawings on this page are not to scale.

Direct Glaze Round Top with GBG or SDL will only align with the default lite cut of the unit it is intended to be milled with.

Sizing Guidelines / Measurement Conversions

Round Top multiple assemblies can be factory mulled up to 3 units wide by 2 units high.

MAXIMUM ROUGH OPENING: 113 1/2" (2883 mm) x 91 1/16" (2313 mm) **or** 85" (2159 mm) x 107 9 1/16" (2732 mm)

NOTES:

Quarter Round shapes require a Casement with a continuous head jamb.

CALCULATING TOTAL ROUGH OPENING FOR ASSEMBLIES

WIDTH: ADD Frame Widths + 1" (25 mm)

Tolerance = 1/2" (13 mm) from the frame to Rough Opening at left and right jamb.

HEIGHT: ADD Frame Heights + 1/2" (13 mm)

Tolerance = 1/2" (13 mm) from Frame to Rough Opening at head jamb.

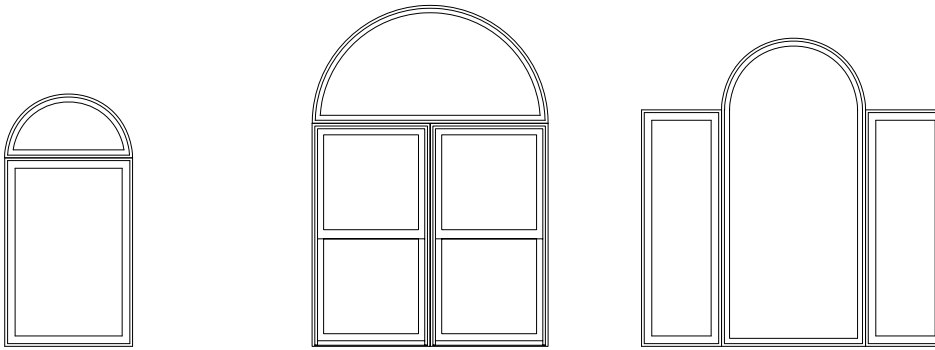

Unit Measurements		Width		Height	
From	To	in	mm	in	mm
Rough Opening		in	mm	in	mm
OSM of Frame (RT1, RT2, RT6, RT7/8, RT29)	Rough Opening	+ 1	(25)	+ 1/2	(13)
OSM of Frame (RT27 - circle, RT28 - oval)	Rough Opening	+ 1	(25)	+ 1	(25)
Masonry Opening (RT1, RT2, RT6, RT7/8, RT29)	Rough Opening	+ 1/2	(13)	+ 1/4	(06)
Masonry Opening (RT27 - circle, RT28 - oval)	Rough Opening	+ 1/2	(13)	+ 3/4	(19)
Daylight Opening (RT1, RT2, RT6, RT7/8, RT29)	Rough Opening	+ 5	(127)	+ 4 1/2	(114)
Daylight Opening (RT27 - circle, RT28 - oval)	Rough Opening	+ 5	(127)	+ 5	(127)
OSM of Glass (RT1, RT2, RT6, RT7/8, RT29)	Rough Opening	+ 3 3/16	(81)	+ 2 11/16	(68)
OSM of Glass (RT27 - circle, RT28 - oval)	Rough Opening	+ 1 1/32	(26)	+ 1 1/32	(26)

Certified Frame-to-Frame Mulling Guidelines

Certified Mull Limits

- If assemblies have individual units that have a lower Performance Grade than the mull, the entire assembly is rated at the lower Performance Grade.
- Mull certification includes 4" mull clips (nail fin installation) or mull brackets (structural bracket installation) at all mull joints.
- Items not included in certified mulls: Stepped mulls, Palladians, Polygon Shapes, Through Jamb, Narrow Frame and Insert Products.

Mull Limits						
Product	Configuration	Max Span	Max TW or TH	Max RO	DP	Max ELDH P height of lower unit
Aluminum Direct Glaze Round Top Casement – Horizontal Continuous LVL Mulling with a Single ELALDG RT on top A-level row	1 - 3W x 2H	72" (1829)	53 11/32" (1355)	73" x 107-9/16" (1854 x 2732)	50	N/A
Aluminum Direct Glaze Round Top Casement – Horizontal Continuous LVL Mulling with RT 7 & 8 on Top A-level row	2W x 2H	72" (1829)	53 11/32" (1355)	73" x 107-9/16" (1854 x 2732)	50	N/A

Tributary Width or Height = (A+B)/2.

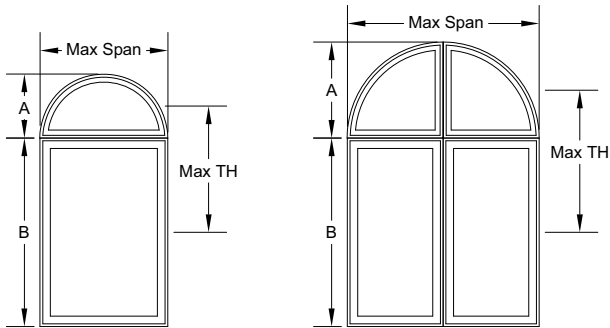

Certified 1/2" MRF Mulling Guidelines

Certified Mull Limits:

- If assemblies have individual units that have a lower Performance Grade than the mull, the entire assembly is rated at the lower Performance Grade.
- Mull certification includes 4" mull clips (nail fin installation) or mull brackets (structural bracket installation) at all mull joints.
- Items not included in certified mulls: Stepped mulls, Palladians, Polygon Shapes, Through Jamb, Narrow Frame and Insert Products.

Mull Limits						
Product	Configuration	Max Span	Max TW or TH	Max RO	DP	Max ELDH P height of lower unit
Aluminum Direct Glaze Round Top Double Hung – Horizontal Continuous 1/2 MRF Mulling with a Single ELALDG RT on top A-level row	1 - 3W x 2H	83" (2108)	53 11/32" (1355)	73" x 107-9/16" (1854 x 2732)	50	N/A
Aluminum Direct Glaze Round Top Double Hung – Horizontal Continuous 1/2" MRF Mulling with RT 7 & 8 on Top A-level row	2W x 2H	72" (1829)	53 11/32" (1355)	73" x 107-9/16" (1854 x 2732)	50	N/A

Tributary Width or Height = $(A+B+1/2)/2$

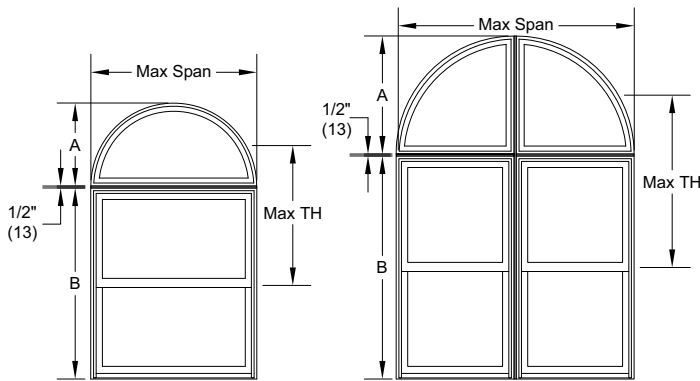

1/2" Mull Reinforcement (MRF) Mulling Examples

Grilles-Between-the-Glass

CASEMENT

DOUBLE HUNG

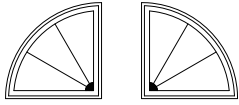

IQCIRM-25-1W CA

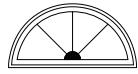

ELALDGRT33-1W CA

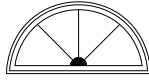

ELALDGRT37-1W CA

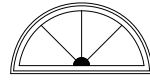

ELALDGRT36-1W DH

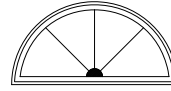

ELALDGRT42-1W DH

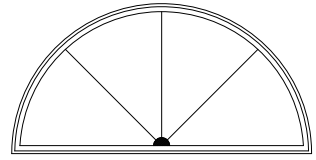

ELALDGRT38-2W DH

EYEBROW ABOVE SPRINGLINE



ELALDGRT 2118 CA



ELALDGRT 2519 CA



ELALDGRT 2920 CA



ELALDGRT 3320 CA

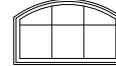

ELALDGRT CA 3722



ELALDGRT 2526 CA/AWN



ELALDGRT 2928 CA/AWN

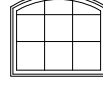

ELALDGRT 3328 CA/AWN

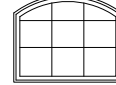

ELALDGRT 3729 CA/AWN

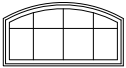

ELALDGRT 4121 CA

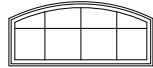

ELALDGRT 4921 CA



ELALDGRT 5724 CA



ELALDGRT 6523 CA



ELALDGRT 7325 CA

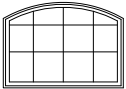

ELALDGRT 4128 CA/AWN

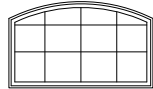

ELALDGRT 4929 CA/AWN

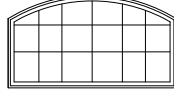

ELALDGRT 5731 CA/AWN

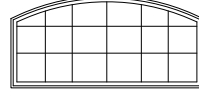

ELALDGRT 6531 CA/AWN

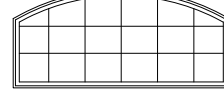

ELALDGRT 7333 CA/AWN

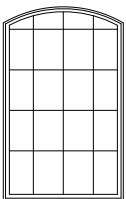

ELALDGRT 4164 CA

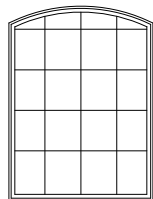

ELALDGRT 4965 CA

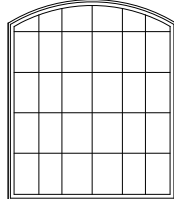

ELALDGRT 5767 CA

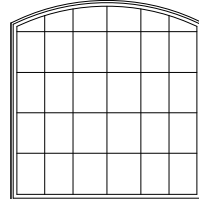

ELALDGRT 6567 CA

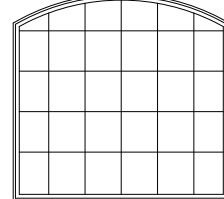

ELALDGRT 7369 CA TEMPERED ONLY

NOTES:

- GBGs are not available on True Half above Springline units
- GBGs may not line up in multiple assemblies. For more information, contact your Marvin representative.

Round Top Examples / Grilles-Between-the-Glass

Multiple Assemblies (examples)

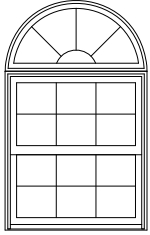

ELALDGRT
36-1W
ELDH3640

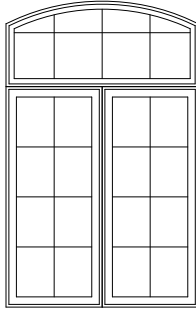

ELALDGRT4921
ELCA 2555 2W

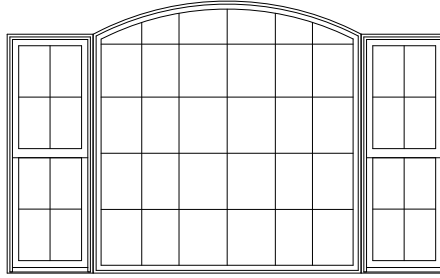

ELDH 2260/ELALDGRT 6868/ELDH 2260

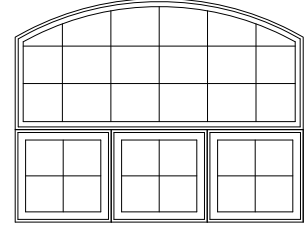

ELALDGRT 7333 /
ELAWN2523 3W

Multiple Assemblies/SDL/GBGS Not Lining Up (Examples)

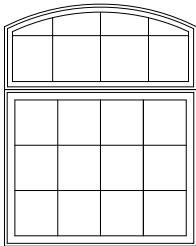

ELALDGRT4921/ELCAP4939

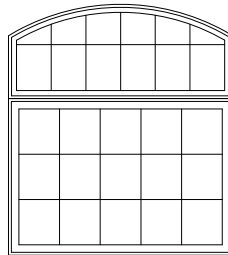

ELALDGRT5724/ELCAP5739

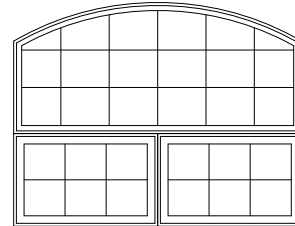

ELALDGRT-
7333/IAWN3723 2W

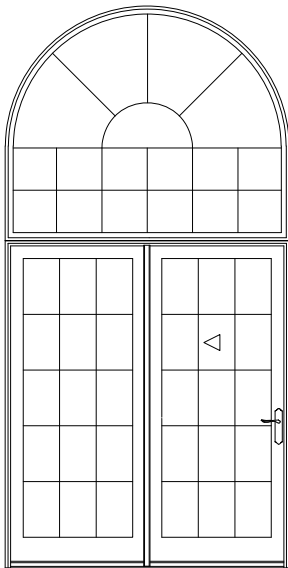

ELALDGRT7259/ELFD6068
(available field mullied only)

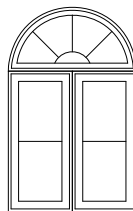

ELALDGRT33 1W/ELCA1735 2W

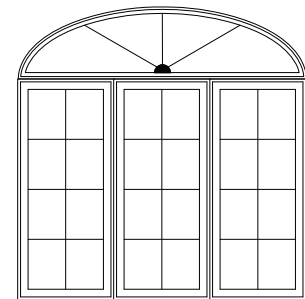

IRTCA7318/ICA 2555-3W

NOTES:

- GBGs are not available on True Half above Springline units
- GBGs may not line up in multiple assemblies. For more information, contact your Marvin representative.

Available Divided Lite Patterns

NOTES:

- GBGs are not available with the ELCA or ELDH Tempered Obscure glass option.
- GBG interior bars are available in White, Ebony, and Bronze only. The GBG exterior color is selectable between Stone White, Pebble Gray, Bronze, Cashmere, Gunmetal, or Ebony.
- White, Clear, and Designer Black interior finishes on Jamb Extensions are available at no additional cost when they match the interior finish of the window. White jamb extensions on a unit with a Designer Black interior are available at an additional cost.
- SDL interior bars are available bare or with White, Clear, or Designer Black interior finish. The SDL exterior finish will be determined by the unit exterior finish.
- For additional window or door options, refer to the Divided Lite Options page in the appropriate product sections.
- SDL with spacer bar available on standard sunburst patterns with an open hub only. SDL with spacer bar is not available on solid or closed hub patterns.
- Direct Glaze RT with GBG or SDL will only align with the default lite cut of the unit is intended to be mull.

AVAILABLE DIVIDED LITE PATTERNS

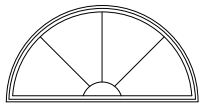

Open Hub, 3 Spokes
Sunburst Lite Cut, GBGs, SDL

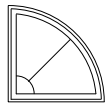

Open Hub, 1 Spoke
Sunburst Lite Cut,
SDL

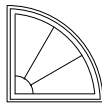

Open Hub, 2 Spokes
Sunburst Lite Cut
GBGs

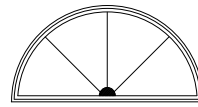

Solid Hub, 3 Spokes
Sunburst Lite Cut
GBGs

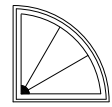

Solid Hub, 2 Spokes
Sunburst Lite Cut
GBGs

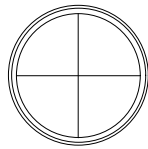

Rectangular Lite Cut 2W2H,
GBGs, SDL

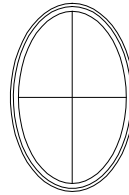

Rectangular Lite Cut,
GBGs, SDL

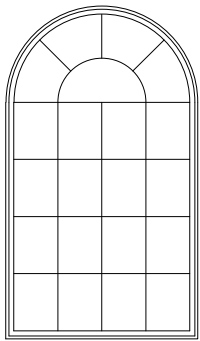

Open Hub, 3 Spokes Sunburst Lite Cut, SDL

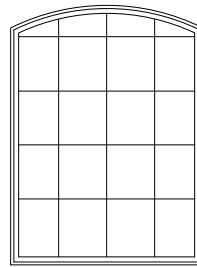
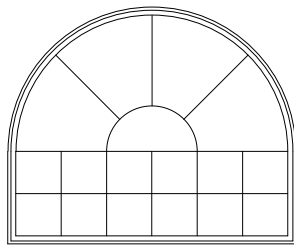

Rectangular Lite Cut, GBGs,SDL

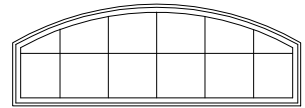

DIVIDED LITE OPTIONS

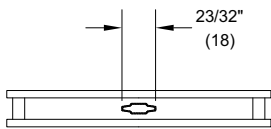

Aluminum Grille Between Glass

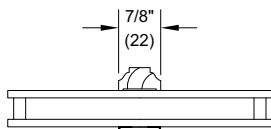

Simulated Divided Lite

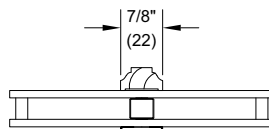

Simulated Divided Lite
With Spacer Bar

Available Divided Lite Patterns

Sunburst Lite Pattern - GBG

Standard CN	Product Series	RT Shape	Unit Alignment	Sunburst Pattern Default	Sunburst Pattern Optional
29-1W	CA	RT7/RT8	ELCA 29-1W	Solid Hub, 2 Spokes	Open Hub, 2 Spokes
29-1W	CA	RT1	ELCA 29-1W	Solid Hub, 3 Spokes	Open Hub, 3 Spokes
21-2W	CA	RT1	ELCA 21-2W	Solid Hub, 3 Spokes	Open Hub, 3 Spokes
25-2W	CA	RT1	ELCA 25-2W, ELCA P 49-1W	Solid Hub, 3 Spokes	Open Hub, 3 Spokes
29-2W	CA	RT1	ELCA 29-2W, ELCA P 57-1W	Solid Hub, 3 Spokes	Open Hub, 3 Spokes
25-3W	CA	RT1	ELCA 25-3W, ELCA 37-2W	Solid Hub, 3 Spokes	Open Hub, 3 Spokes
7318	CA	RT29	ELCA 25-3W, ELCA 37-2W	Solid Hub, 3 Spokes	Open Hub, 3 Spokes
30-1W	DH	RT1	ELDH 30-1W	Solid Hub, 3 Spokes	Open Hub, 3 Spokes
34-1W	DH	RT1	ELDH 34-1W	Solid Hub, 3 Spokes	Open Hub, 3 Spokes
38-1W	DH	RT1	ELDH 38-1W	Solid Hub, 3 Spokes	Open Hub, 3 Spokes
34-2W	DH	RT1	ELDH 34-2W	Solid Hub, 3 Spokes	Open Hub, 3 Spokes
36-2W	DH	RT1	ELDH 36-2W	Solid Hub, 3 Spokes	Open Hub, 3 Spokes
7218	DH	RT29	ELDH 36-2W	Solid Hub, 3 Spokes	Open Hub, 3 Spokes
7236	DR	RT1	ELSPD, ELSFD, ELIFD, ELOFD 60-1W	Solid Hub, 3 Spokes	Open Hub, 3 Spokes
7218	DR	RT29	ELSPD, ELSFD, ELIFD, ELOFD 60-1W	Solid Hub, 3 Spokes	Open Hub, 3 Spokes

Sunburst Lite Pattern - SDL

Standard CN	Product Series	RT Shape	Unit Alignment	Sunburst Pattern Default
29-1W	CA	RT7/RT8	ELCA 29-1W	Open Hub, 1 Spoke
29-1W	CA	RT1	ELCA 29-1W	Open Hub, 3 Spokes
21-2W	CA	RT1	ELCA 21-2W	Open Hub, 3 Spokes
25-2W	CA	RT1	ELCA 25-2W, ELCA P 49-1W	Open Hub, 3 Spokes
29-2W	CA	RT1	ELCA 29-2W, ELCA P 57-1W	Open Hub, 3 Spokes
25-3W	CA	RT1	ELCA 25-3W, ELCA 37-2W	Open Hub, 3 Spokes
7318	CA	RT29	ELCA 25-3W, ELCA 37-2W	Open Hub, 3 Spokes
30-1W	DH	RT1	ELDH 30-1W	Open Hub, 3 Spokes
34-1W	DH	RT1	ELDH 34-1W	Open Hub, 3 Spokes
38-1W	DH	RT1	ELDH 38-1W	Open Hub, 3 Spokes
34-2W	DH	RT1	ELDH 34-2W	Open Hub, 3 Spokes
36-2W	DH	RT1	ELDH 36-2W	Open Hub, 3 Spokes
7218	DH	RT29	ELDH 36-2W	Open Hub, 3 Spokes
7236	DR	RT1	ELSPD, ELSFD, ELIFD, ELOFD 60-1W	Open Hub, 3 Spokes
7218	DR	RT29	ELSPD, ELSFD, ELIFD, ELOFD 60-1W	Open Hub, 3 Spokes

Available Divided Lite Patterns

Rectangular Lite Pattern - SDL, GBG

Standard CN	Product Series	RT Shape	Unit Alignment	Rectangular Pattern Default
2118	CA	RT6	ELCA TR 16H ELCA 21-1W	2W2H
2519	CA/AWN	RT6	ELCA TR 16H ELCA/ELAWN 25-1W	2W2H
2526	CA/AWN	RT6	ELAWN 23H ELCA/ELAWN 25-1W	2W3H
2920	CA	RT6	ELCA TR 16H ELCA/ELAWN 29-1W	3W2H
2928	CA/AWN	RT6	ELAWN 23H ELCA/ELAWN 29-1W	3W3H
3320	CA	RT6	ELCA TR 16H ELCA/ELAWN 33-1W	3W2H
3328	CA/AWN	RT6	ELAWN 23H ELCA/ELAWN 33-1W	3W3H
3722	CA	RT6	ELCA TR 16H ELCA/ELAWN 37-1W	3W2H
3729	CA/AWN	RT6	ELAWN 23H ELCA/ELAWN 37-1W	3W3H
4121	CA	RT6	ELCA TR 16H ELCA 21-2W	4W2H
4128	CA/AWN	RT6	ELAWN 23H ELCA 21-2W	4W3H
4164	CA	RT6	ELCA 59H ELCA 21-2W	4W5H
4921	CA/AWN	RT6	ELCA TR 16H ELCA/ELAWN 25-2W	4W2H
4929	CA/AWN	RT6	ELAWN 23H ELCA/ELAWN 25-2W	4W3H
4965	CA/AWN	RT6	ELCA 59H ELCA/ELAWN 25-2W	4W5H
5724	CA/AWN	RT6	ELCA TR 16H ELCA/ELAWN 29-2W	6W2H
5731	CA/AWN	RT6	ELAWN 23H ELCA/ELAWN 29-2W	6W3H
5767	CA/AWN	RT6	ELCA 59H ELCA/ELAWN 29-2W	6W5H
6523	CA/AWN	RT6	ELCA TR 16H ELCA/ELAWN 33-2W	6W2H
6531	CA/AWN	RT6	ELAWN 23H ELCA/ELAWN 33-2W	6W3H
6567	CA/AWN	RT6	ELCA 59H ELCA/ELAWN 33-2W	6W5H
7325	CA/AWN	RT6	ELCA TR 16H ELCA/ELAWN 25-3W	6W2H
7333	CA/AWN	RT6	ELAWN 23H ELCA/ELAWN 25-3W	6W3H
7369	CA/AWN	RT6	ELCA 59H ELCA/ELAWN 25-3W	6W5H

NOTE: Direct Glaze Round Tops with GBGs or SDL will only align with the lite cut of the unit it is intended to be muller with.

Available Divided Lite Patterns

Rectangular Lite Pattern - SDL, GBG

Standard CN	Product Series	RT Shape	Unit Alignment	Rectangular Pattern Default
2619	DH	RT6	ELDH TR 16H ELDH 26-1W	3W2H
3021	DH	RT6	ELDH TR 16H ELDH 30-1W	3W2H
3421	DH	RT6	ELDH TR 16H ELDH 34-1W	3W2H
3622	DH	RT6	ELDH TR 16H ELDH 36-1W	3W2H
3820	DH	RT6	ELDH TR 16H ELDH/ELDH P 38-1W	4W2H
4222	DH	RT6	ELDH TR 16H ELDH/ELDH P 42-1W	4W2H
5222	DH	RT6	ELDH TR 16H ELDH 26-2W	6W2H
5622	DH	RT6	ELDH TR 16H ELDH 26-2W	6W5H
6025	DH/DR	RT6	ELDH TR 16H ELDH 30-2W	6W2H
6032	DH/DR	RT6	ELDH TR 16H ELDH 30-2W	6W3H
6069	DH/DR	RT6	ELDH 60H ELDH 30-2W	6W5H
6824	DH	RT6	ELDH TR 16H ELDH 34-2W	6W2H
6868	DH	RT6	ELDH 60H ELDH 34-2W	6W5H
7225	DH/DR	RT6	ELDH TR 16H ELDH 36-2W	6W2H
7233	DH/DR	RT6	ELDH 36-2W	6W3H
7269	DH/DR	RT6	ELDH 36-2W	6W5H
7626	DH/DR	RT6	ELDH TR 16H ELDH/ELDH P 38-2W	8W2H
7670	DH	RT6	ELDH 60H ELDH/ELDH P 38-2W	8W5H
8429	DH	RT6	ELDH TR 16H ELDH/ELDH P 42-2W	8W2H
8473	DH	RT6	ELDH 60H ELDH/ELDH P 42-2W	8W5H

NOTE: Direct Glaze Round Tops with GBGs or SDL will only align with the lite cut of the unit it is intended to be mullied with.

Section Details - Casement

CASEMENT - 4 9/16"

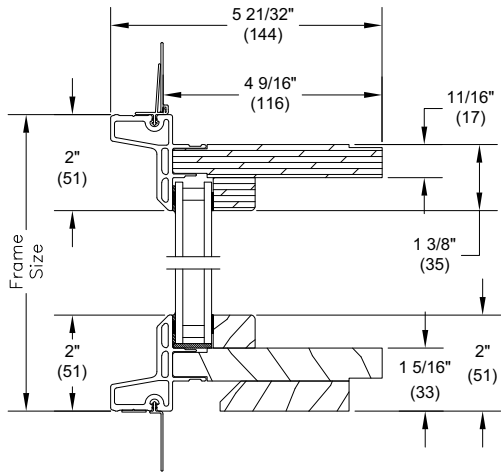

CASEMENT - 6 9/16"

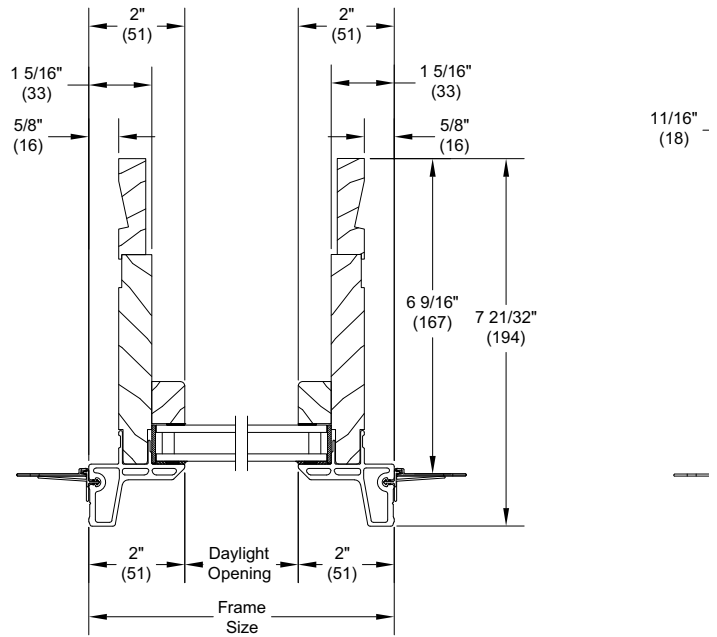
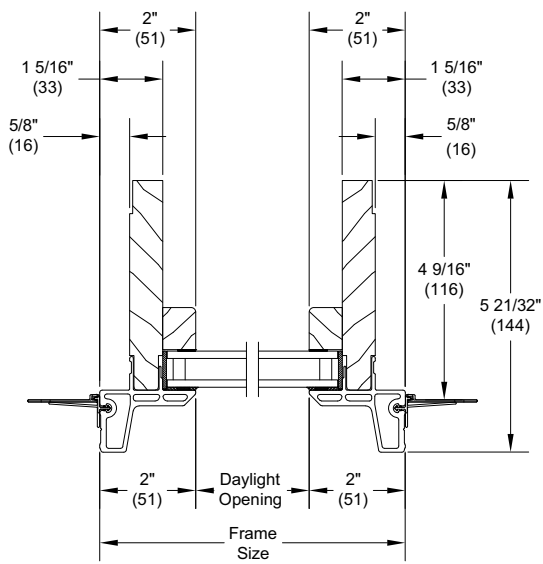
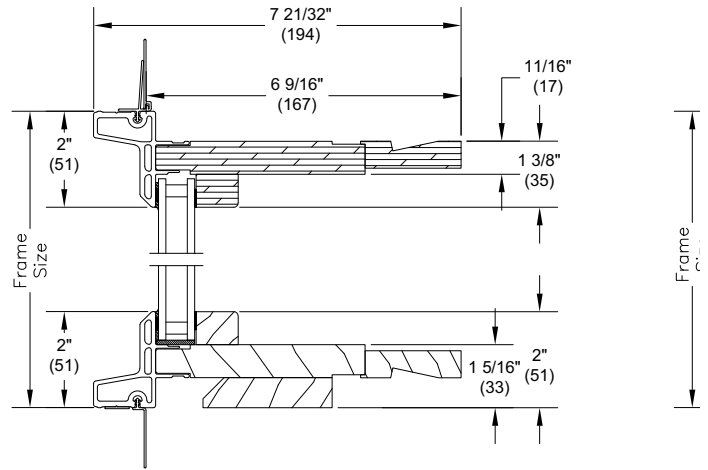

Section Details - Double Hung/Door

DOUBLE HUNG/DOOR - 4 9/16"

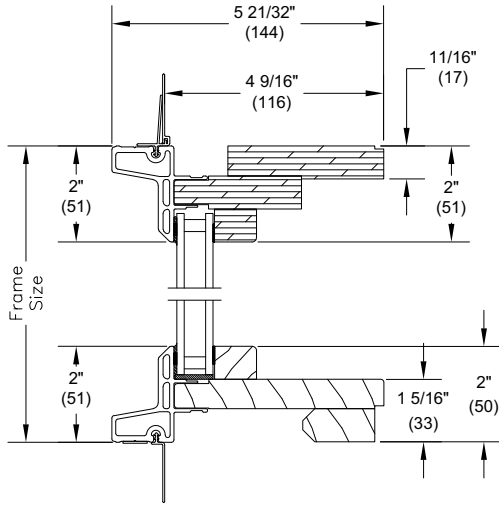

DOUBLE HUNG/DOOR - 6 9/16"

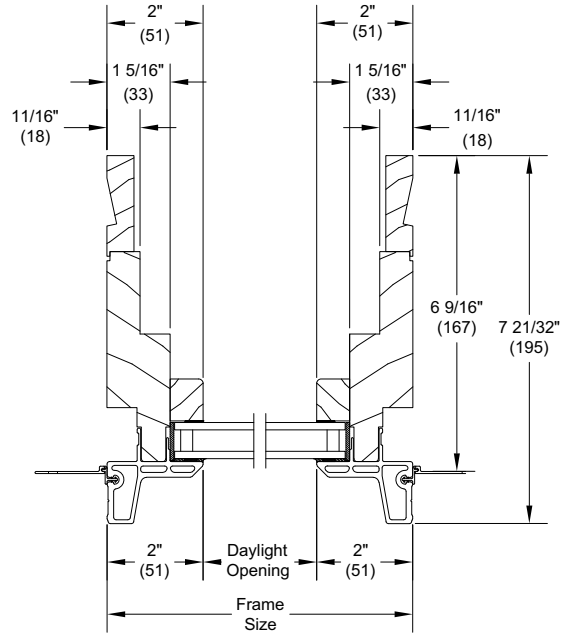
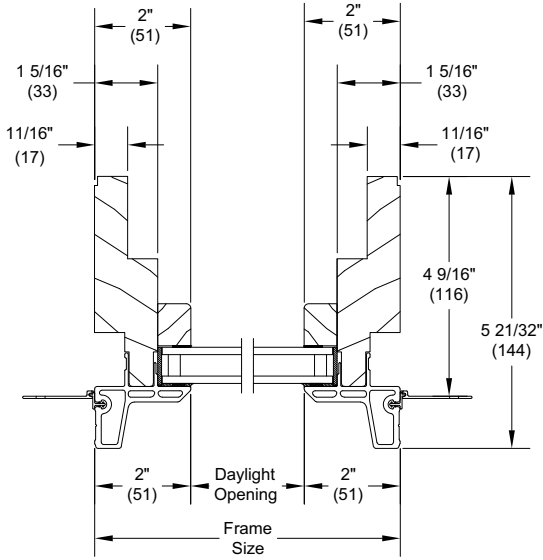
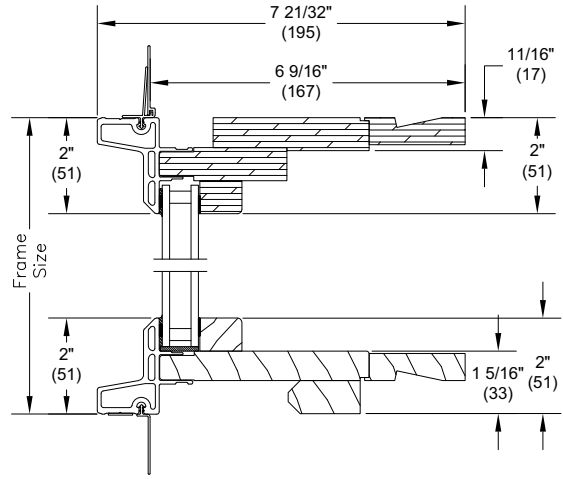

Section Details - Mullions

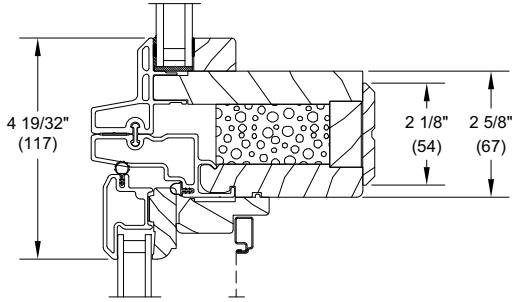

**Round Top
Over Operating Casement**

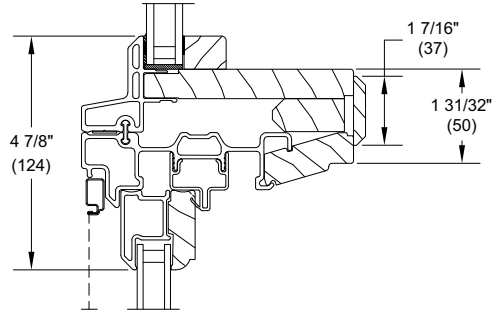

**Round Top
Over Double Hung**

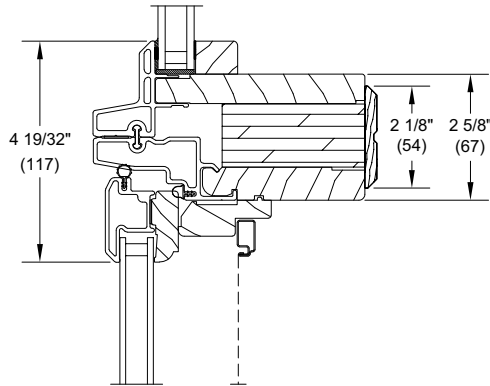

**Round Top
Casement
With LVL Support**

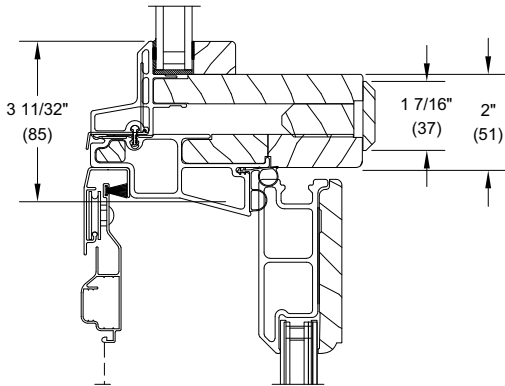

**Round Top
Over Swinging Door**

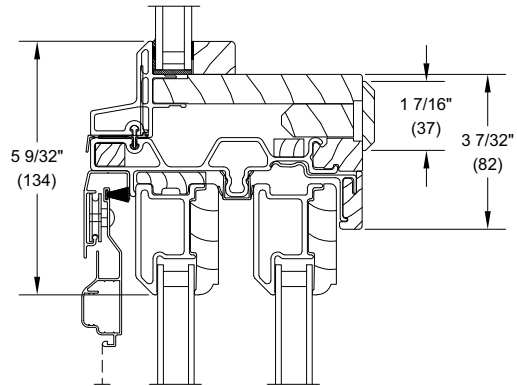

**Round Top
Over Patio Door**

Section Details - 1/2" MRF Mullions

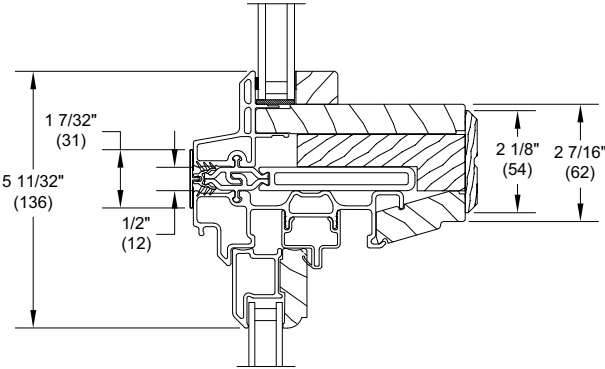

Round Top
Over Double Hung

Installation Suggestion - Brick Veneer with Steel Frame Construction

Elevate Aluminum
Direct Glaze Round Top
Casement

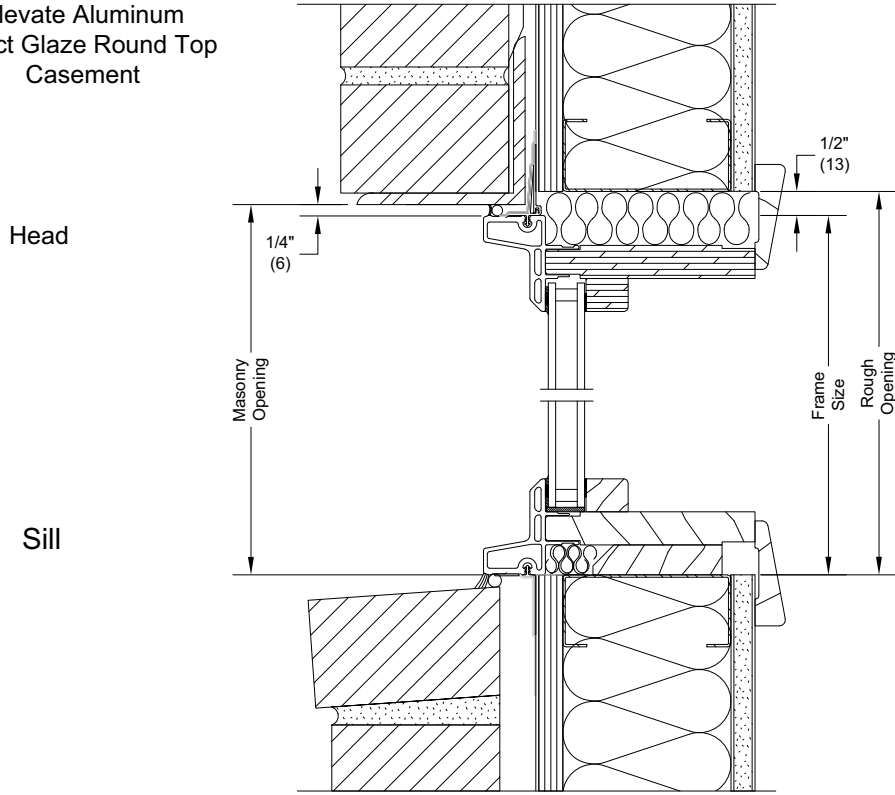

Elevate Aluminum
Direct Glaze Round Top
Double Hung / Door Transom

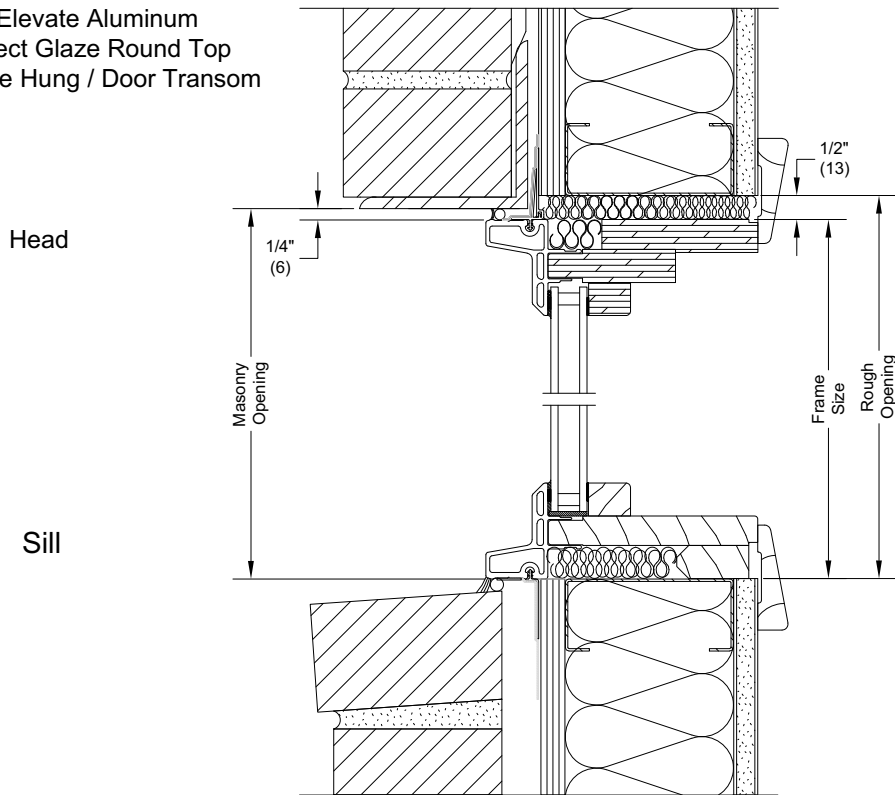

NOTE: The above wall sections represent typical wall conditions, these details are not intended as installation instructions. Please refer to the installation instructions provided with the purchased units.

Installation Suggestion - Wood Siding with Frame Construction

Elevate Aluminum
Direct Glaze Round Top
Casement

Head

Sill

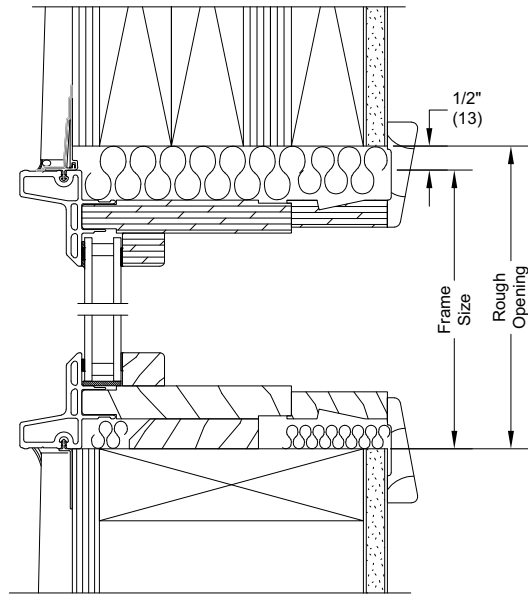

Wood Siding With 2X6 Frame Construction

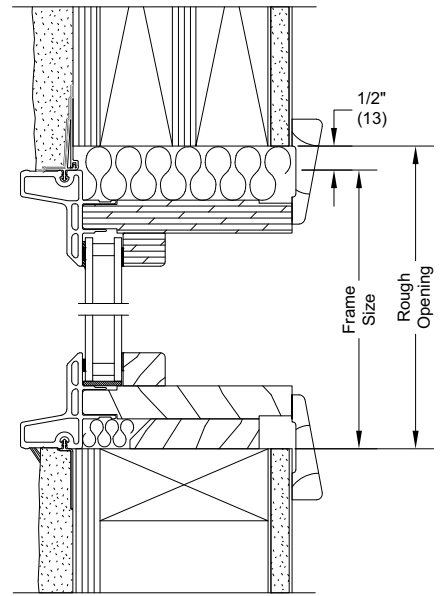

Stucco With 2X4 Frame Construction

Elevate Aluminum
Direct Glaze Round Top
Double Hung / Door Transom

Head

Sill

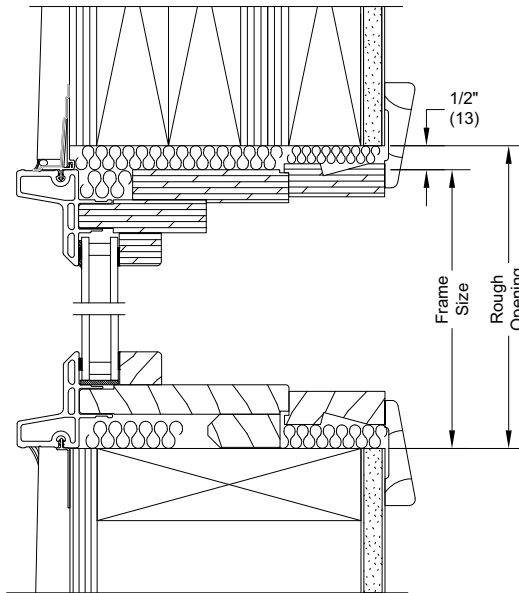

Wood Siding With 2X6 Frame Construction

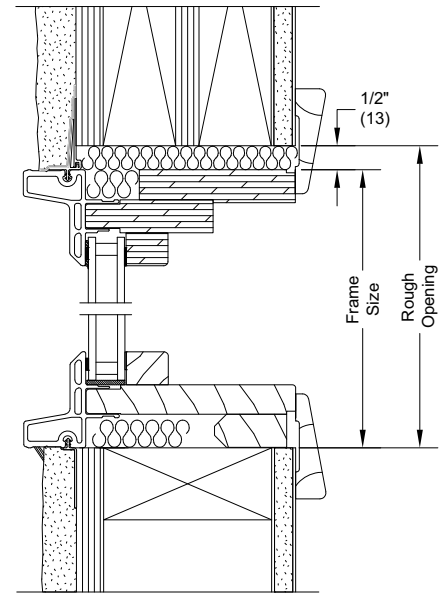

Stucco With 2X4 Frame Construction

NOTE: Round Top unit shown with jamb extension

The above wall sections represent typical wall conditions, these details are not intended as installation instructions. Please refer to the installation instructions provided with the purchased units.