

Elevate Bi-Fold Door

Installation Instruction



Abstract

Please read these instructions in their entirety before beginning to install your Marvin Door product. These installation instructions demonstrate the installation of an Marvin door in new wood frame construction using an industry approved water management system. For installation using other construction methods, such as remodeling, replacement, and recessed openings refer to ASTM E2112-07, "Standard Practice for Installation of Exterior Windows, Doors and Skylights," for installation suggestions. The same information for ASTM E2112 can be found on the ASTM website, www.astm.org. Regional standard practices, environmental conditions, and codes may vary and supersede the procedures contained within. The responsibility for compliance is yours: the installer, inspector, and owner(s).

After Market Products

Alterations to Marvin products including films, insulating or reflective interior window treatments or additional glazings can cause excessive heat buildup and/or condensation. They may lead to premature failures not covered under warranty by Marvin Windows and Doors.

Before purchasing or applying any product that may affect the installation or performance of Marvin windows or doors, contact the manufacturer of after market product/glazings that are not supplied by Marvin and request written product use, associated warranties and damage coverage. Provide this information and warranties to the end user and/or building owner for future reference.

WARNING!

Always practice safety! Wear the appropriate eye, ear, and hand protection, especially when working with power tools.

WARNING!

This product can expose you to chemicals including titanium oxide, which is known to the state of California to cause cancer. For more information, go to www.P65Warnings.ca.gov.

WARNING!

Drilling, sawing, sanding or machining wood products can expose you to wood dust, a substance known to the State of California to cause cancer. Avoid inhaling wood dust or use a dust mask or other safeguards for personal protection. For more information go to www.P65Warnings.ca.gov/wood.



Seek Assistance

Doors and/or assemblies are very heavy. Avoid injury by getting help to lift and position into the rough opening.

IMPORTANT

Unfactored superimposed load (Live, Wind, or Snow) deflection over the entire length of the unsupported span cannot be greater than 1/8" (3) after natural sag of the beam and permanent loads are in place.

Protective Film

This product features a clear protective film adhered to the glass surfaces to protect them from construction debris, dust, dirt, stucco, etc. When construction is complete, simply peel the film off and dispose of it with other construction debris. Please refer to the [manufacturer's website](#) and bulletin for more information on the physical properties and usage of the protective film.

IMPORTANT

Do not use a razor blade to remove the protective film. Do not use a pressure washer to clean debris from the film. The film should be removed within nine months of application.

Installation Video*



To watch a video on this installation, scan the QR code with your smart phone or similar device or click on this link (<https://www.youtube.com/watch?v=4FEe2YxbC7s>).

****Refer to the Site Prep Guide prior to installation.***

Tools and Parts (Supplied in Job Box)

- Silicone for Frame Assembly
- Hardware
- Configuration Diagram
- 2mm and 5mm Hex Key

Fastener bags are labeled for application. There are a variety of hinges and pivots in individual boxes. Hinge/pivot boxes are labeled for application. **Keep hinges, carriers and pivots with boxes** until ready to use for easier identification.

You Will Need to Supply

- Safety Glasses
- Hearing protection
- Caulking Gun
- Mallet
- Drill
- Phillips #2 screwdriver
- Phillips #2 bit
- T25 bit
- 1/8" drill bit
- Step ladder
- 25' Tape measure
- Utility knife
- Wood support blocks
- Level and/or laser
- Wood shims
- 2" Roofing nails (for Nailing Fin Installation)
- Insulation
- Perimeter sealant
- Sill Panning
- Backing material (foam backing rod)
- Low expansion foam insulation
- Flashing materials
- Weather resistive barrier
- 3/32" Hex Key
- String line
- Suction cups
- Lifting equipment
- Tapcons as needed

Frame Assembly

For frame widths greater than 189", complete splicing instructions on pages 18-22 before continuing with frame assembly.

1. Insert corner keys into side jambs. See Figure 1.

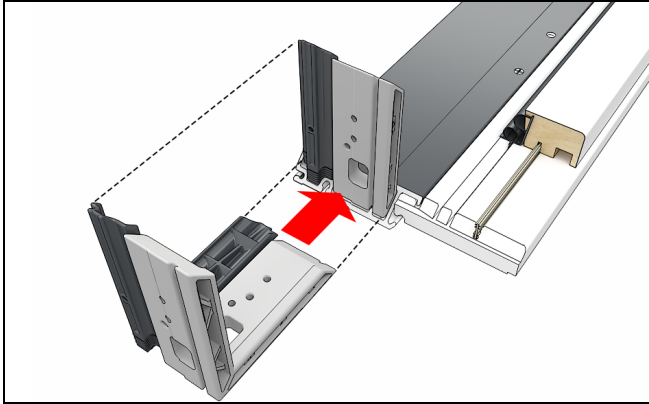

Figure 1

2. Apply silicone to head jamb miters. See Figure 2.

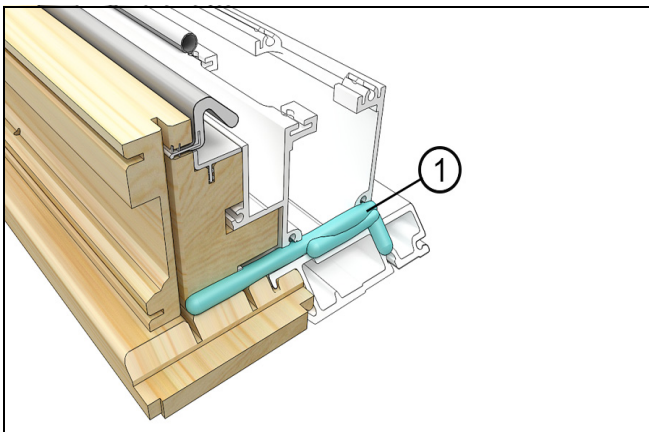

Figure 2

1	Silicone
---	----------

3. Fasten the side jambs to the head jamb. Do not over tighten miter joint. See Figure 3.

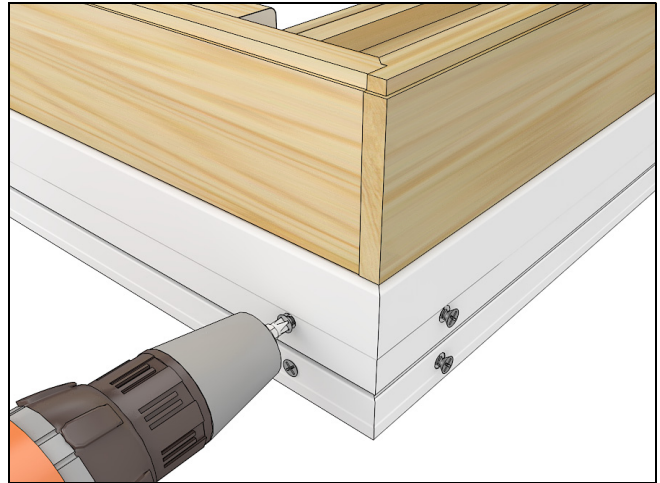

Figure 3

1	Four per side- #8 x 1/2" Flat head screws
---	---

4. Pre-drill 1/8" pilot holes a maximum of 5/8" deep and fasten screws. See Figure 4 and Figure 5.

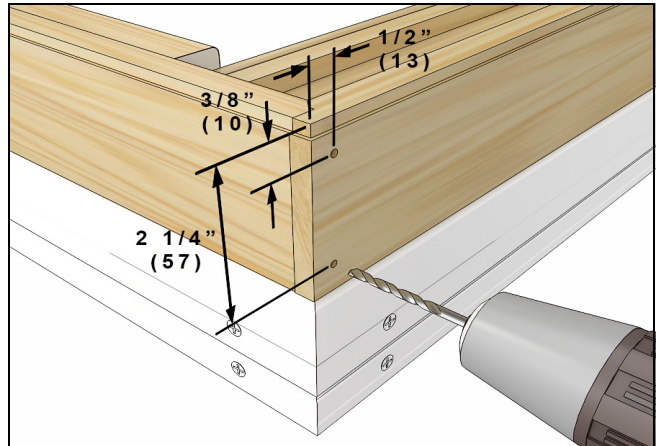

Figure 4

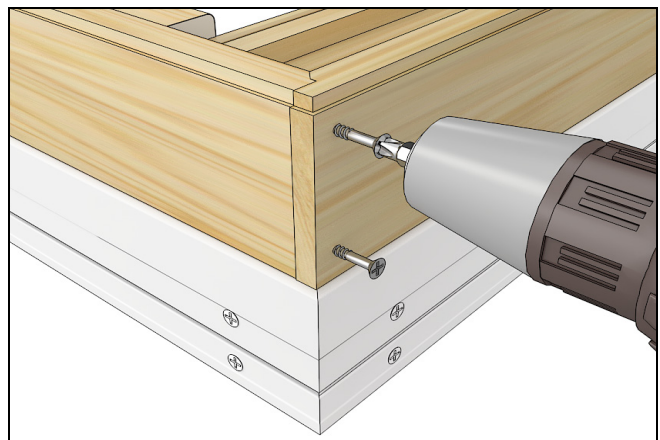

Figure 5

1	2 per side- #7 x 1-1/4" Flat head screws
---	--

5. Fasten the sill to the side jambs (short screws first and replace the interior sill screw with the 4" Panhead). See Figure 6.

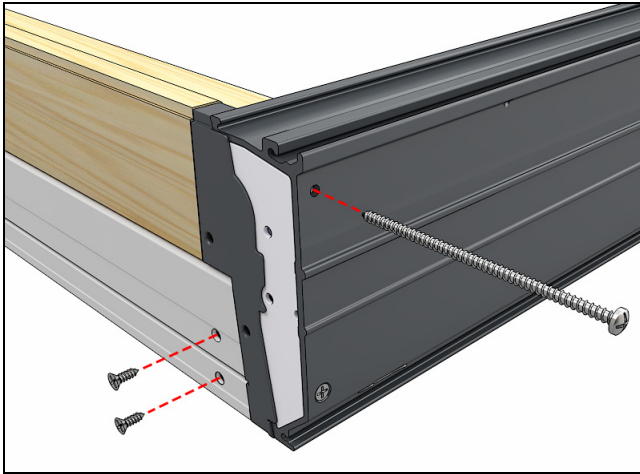

Figure 6

1	2 per side- #8 x 1/2" Flathead screws
2	1 per side- #8 x 4" Panhead screw

6. Inject the sill until squeeze out occurs in both locations. *NOTE: Inject the interior hole first for cleanliness.* Clean up excessive silicone squeeze out as necessary. See Figure 7, Figure 8, and Figure 9.

ATTENTION

Ensure you see silicone at specified indicators to ensure proper injection and water performance.

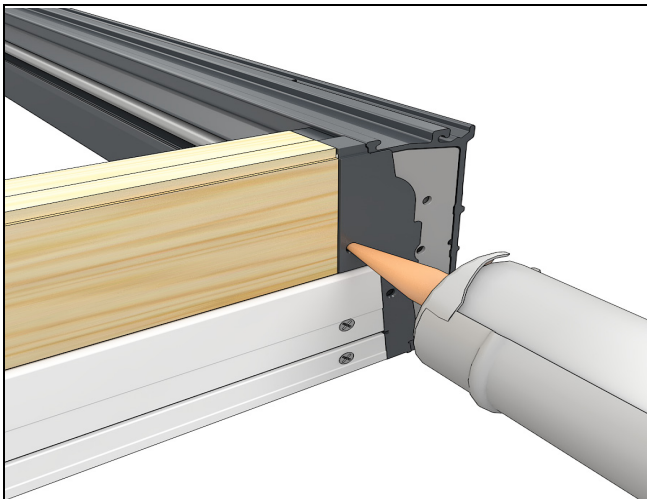

Figure 7 Inject interior hole first

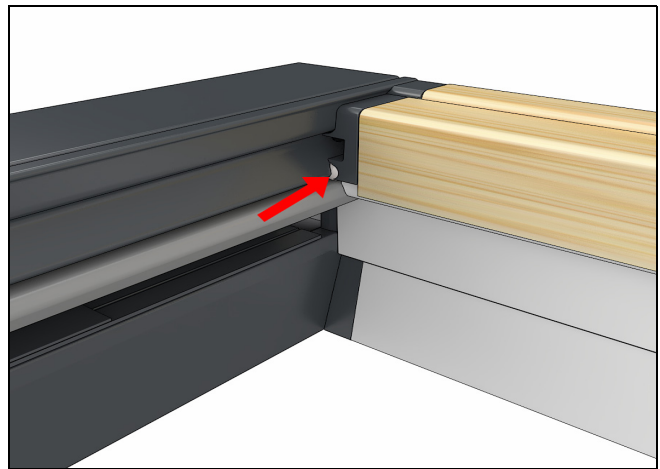

Figure 8 Squeeze out location

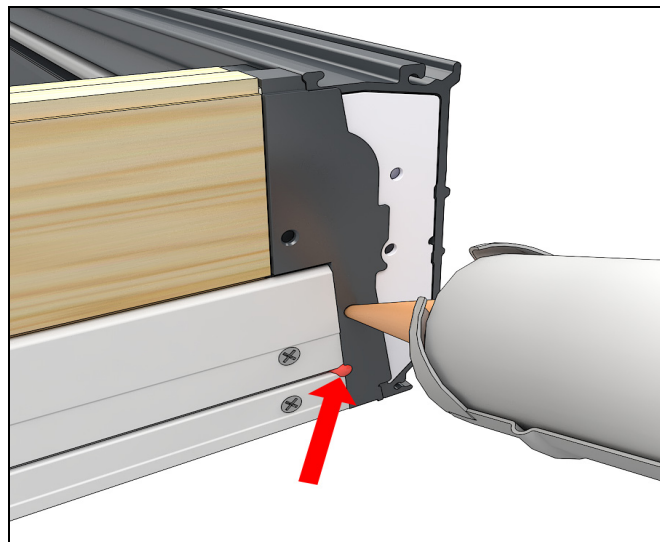

Figure 9 Secondary injection hole with squeeze out location

7. If applicable, attach jamb extensions. Refer to the Elevate Jamb Extension Field Applied Instructions for more details.

Frame Installation

NOTE: Before installation, ensure the Rough Opening has been prepped according to the Site Prep Guide. For additional instructions, such as nailing fin installation, refer to [Doors General Installation Instructions](#).

1. Apply three continuous beads of silicone to the top of the sill pan. See [Figure 10](#).

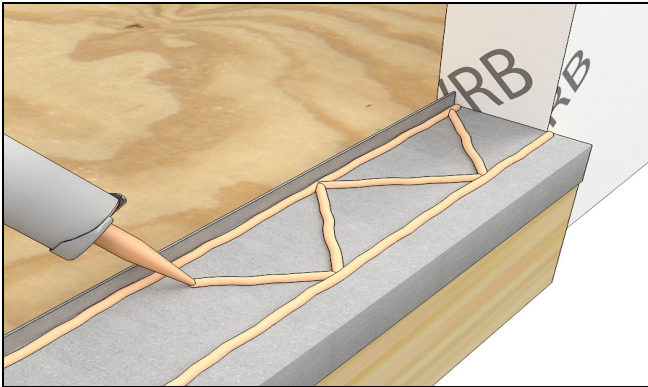

Figure 10

2. If applicable, attach the head jamb nailing fin, then install centered frame into rough opening. See [Figure 11](#).

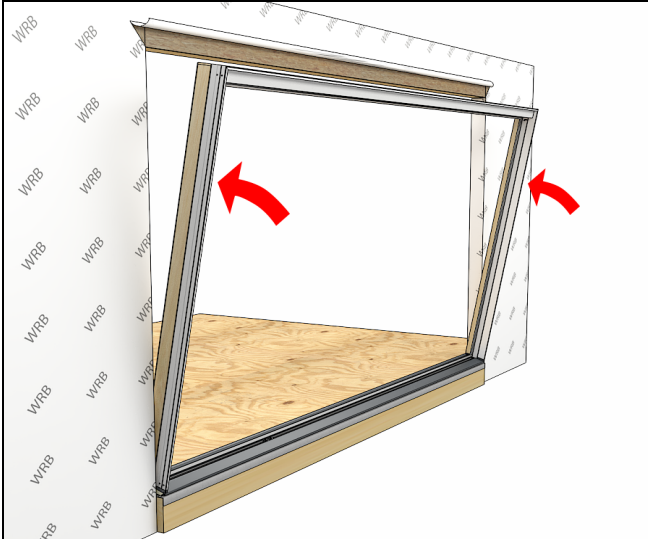

Figure 11

3. **Frame Tolerance:** the sill must be within +/- 1/16" (3) flat. The head jamb must be flat or within +1/8" (1) of flat (not bowed down). When installed, the frame must be within +/- 3/16" (2) of square. See [Figure 12](#).

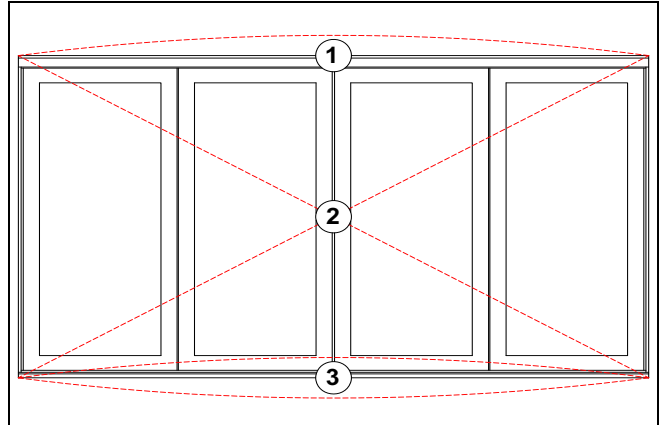

Figure 12

1	Head Jamb within +1/8" and flat
2	Square frame within $\pm 3/16$ "
3	Sill within $\pm 1/16$ "

4. Fasten sill through all pre-drilled holes. Apply sealant to the threads of each screw prior to fastening. Use appropriate fastener for rough opening materials. ((#8 x 1-1/2" screws minimum if using flat sill pan. Refer to Site Prep Guide for alternative installation methods). See [Figure 13](#).

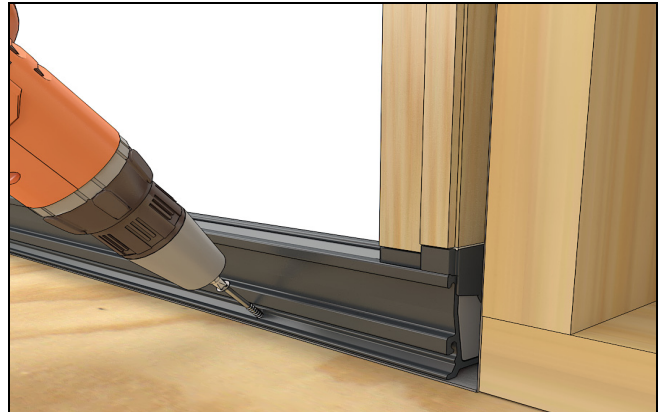

Figure 13

1	#8 x 1 1/2" screws minimum
---	----------------------------

5. Fasten jambs through all pre-drilled holes, shims should be placed at all fastening locations. Add additional shims as necessary to maintain maximum spacing of 15". Additionally, place shims 4"-6" from each corner. See [Figure 14](#).



Figure 14

1	#8 x 2 1/2" Flat head screws
---	------------------------------

6. Ensure heads of all jamb screws are flush with jamb. Apply a dab of silicone to the heads of each jamb install screw including upper and lower factory installed screws used for shipping. See Figure 15.

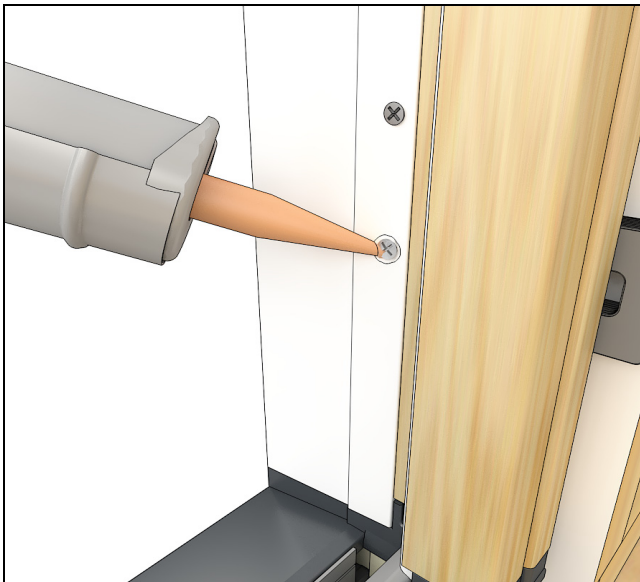

Figure 15

7. Place shims at each head jamb install screw location. Fasten the head jamb track through all the pre-drilled holes and test fit carrier. Apply sealant to the threads and heads of each screw prior to fastening. See Figure 16. NOTE: These screws are installed at a slight angle towards the interior.

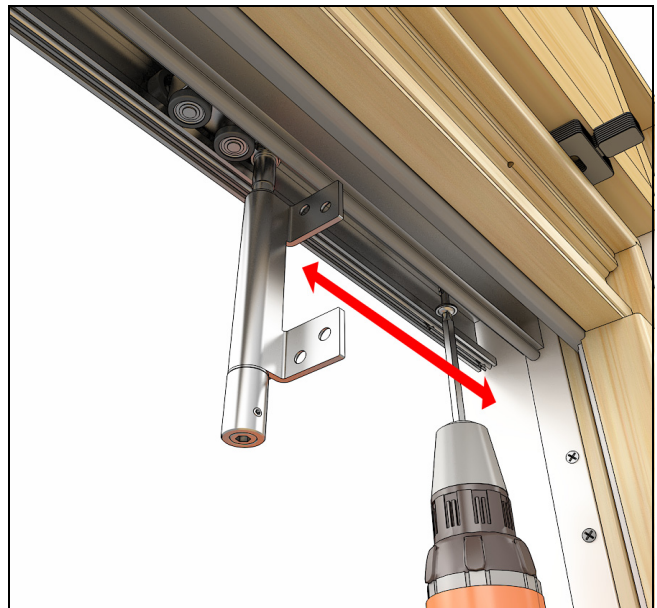

Figure 16

1	1/4" x 3-1/8" Washer head screw
---	---------------------------------

ATTENTION

Do not over-tighten screws in head track to ensure smooth hardware operation. See Figure 17.

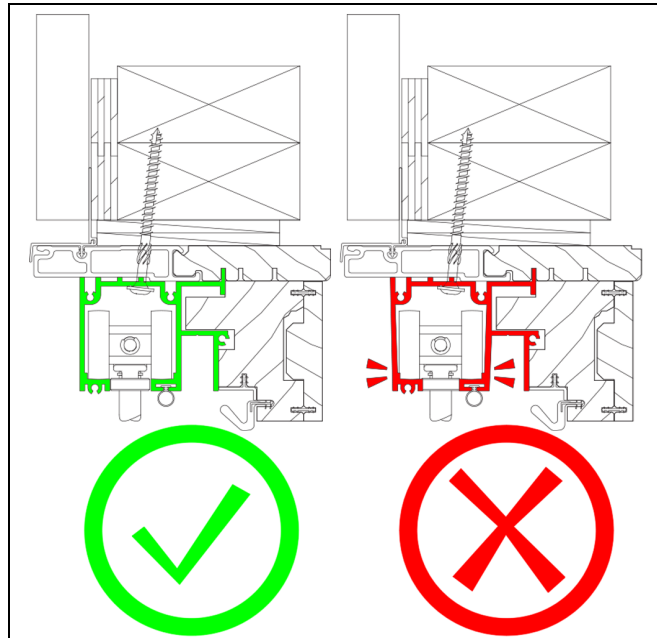

Figure 17

8. Fasten head jamb stop screws at all pre-drilled locations without a fastener already. See [Figure 18](#).



Figure 18

1	#8 x 3" Pan head screws
---	-------------------------

9. Install the jamb covers. Slide cover up between the head track and jamb. See [Figure 19](#).

NOTE: If having difficulty installing the covers, remove the side jamb weather strips and use a rubber mallet. Reinstall the weather strips after the covers.

NOTE: On locking jambs, install the jamb cover with the pre-punched holes for the strike.

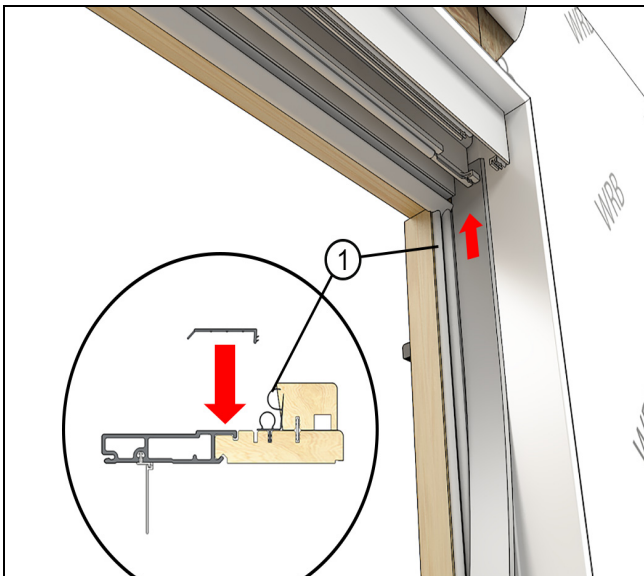

Figure 19

1	Jamb cover
2	Side jamb weather strip

10. If applicable, install the strike plate subassembly using the pre-drilled holes. Ensure there are shims behind the jamb at the screw holes. See [Figure 20](#).

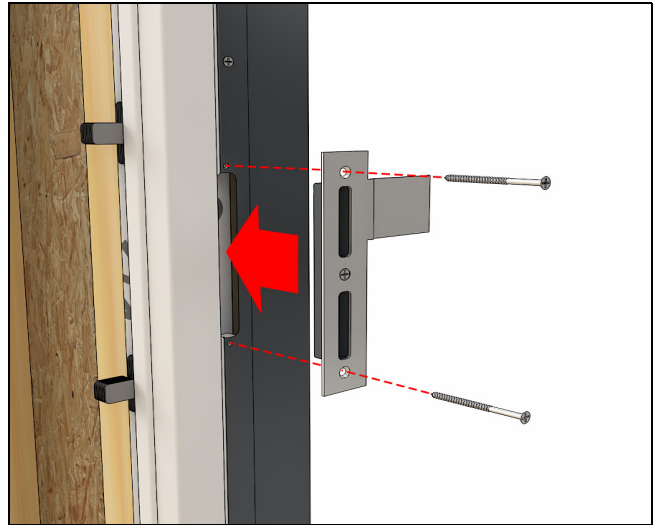

Figure 20

1	#8 x 2 1/2" Flat head
---	-----------------------

Hinge Installation

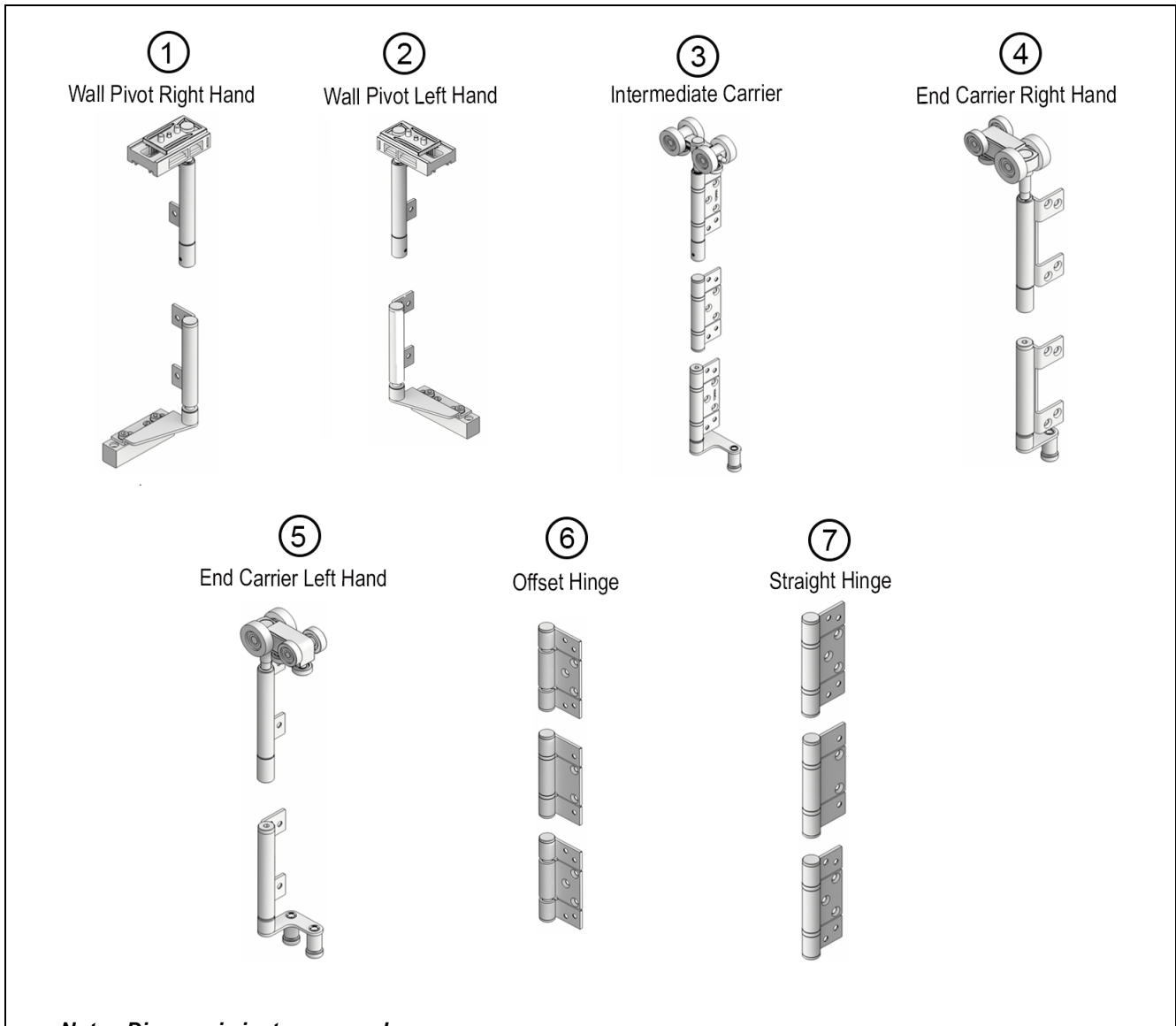

Figure 21

NOTE: For information on configuration and hinge placement, please refer to the diagram enclosed, similar to [Figure 22](#).

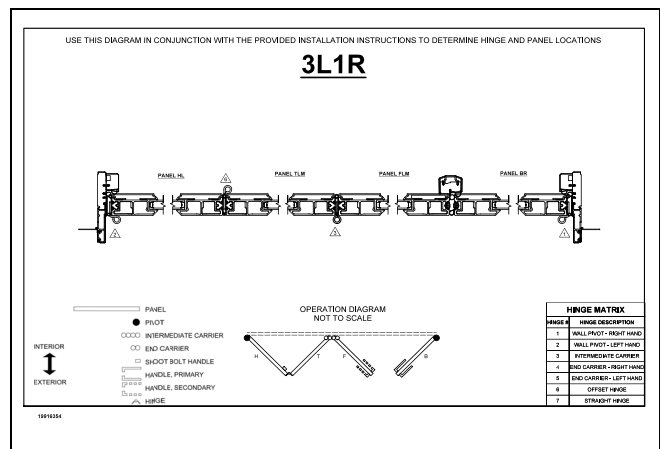

Figure 22

1. Install the top portion of all hardware numbered 1-5 in the head jamb track through the access route in the correct order and orientation. See [Figure 23](#) and [Figure 24](#). These are just examples of attaching hardware- follow configuration diagram for reference and correct orientation of the hardware placement.



Figure 23

1	End Carrier Left Hand (#5)
---	----------------------------



Figure 24

1	Intermediate carrier (#3)
---	---------------------------

2. Fasten the pivot(s) to the head jamb track. See [Figure 25](#).



Figure 25

1	#7 X 3/4" Pan head screw
2	Wall Pivot Right Hand (#1)

3. Lower the pivot flags towards the sill through loosening the set screw, turning the adjustment cam, and tightening the set screw. See [Figure 26](#).



Figure 26

ATTENTION

When lowering hardware, do not exceed the specified dimension in [Figure 27](#) or the hardware will disassemble.

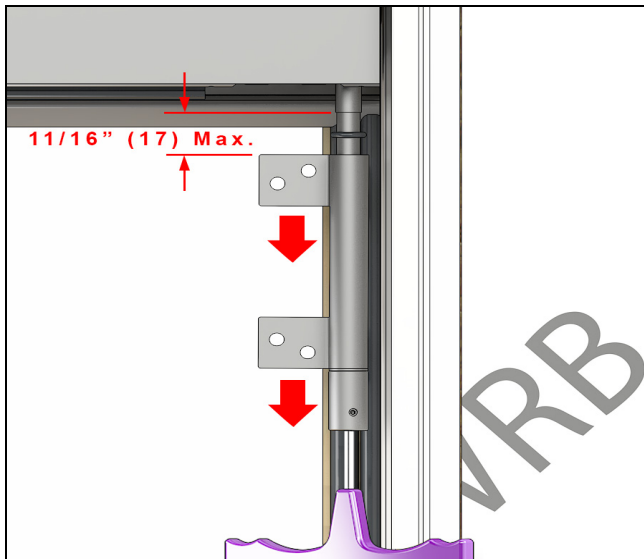

Figure 27

4. Disassemble the bottom pivot(s). See [Figure 28](#).



Figure 28

5. Install pivot base through pre-drilled holes in the aluminum track. Use proper fastener for Rough Opening material with silicone applied to screw threads. (#8 x 2-1/2" Flathead screw minimum.) See [Figure 29](#).



Figure 29

1	Minimum #8 x 2-1/2" Flathead screw
---	------------------------------------

6. Assemble pivot in the middle of its adjustment range, tighten adjustment screws, and slide on hinge flag. See [Figure 30](#) and [Figure 31](#).

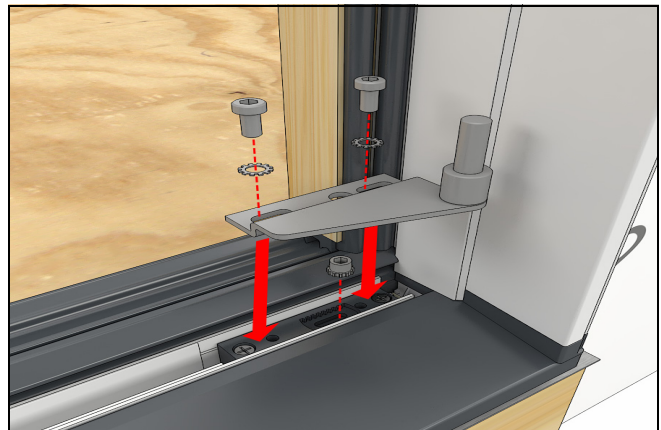

Figure 30

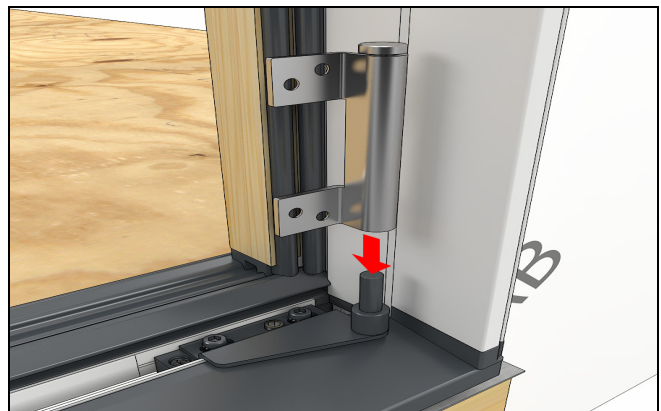

Figure 31

Panel Installation

1. Panels are lettered according to configuration diagram. Install the panels one at a time, starting from any hardware numbered 1 or 2 and working across. Repeat from the other jamb if necessary. Refer to the configuration diagram enclosed similar to [Figure 32](#)

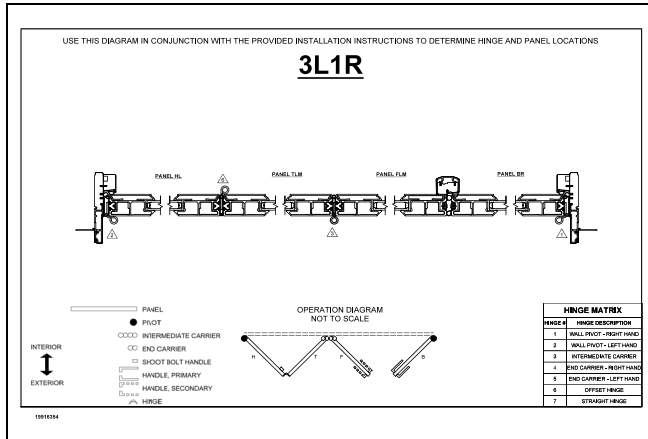

Figure 32

2. The twin bolt handle can be installed before or after the panels are installed, based on installers preference. When the twin bolt handle is pointed downward shown in [Figure 33](#) below, the bolts should be fully engaged/extended. [Figure 34](#) is the locked position.



Figure 33



Figure 34

3. In the horizontal position (half turn) the twin bolt handle should be pointed towards the middle of the panel not the hinge line. See [Figure 35](#). This position should also be used for screw install.

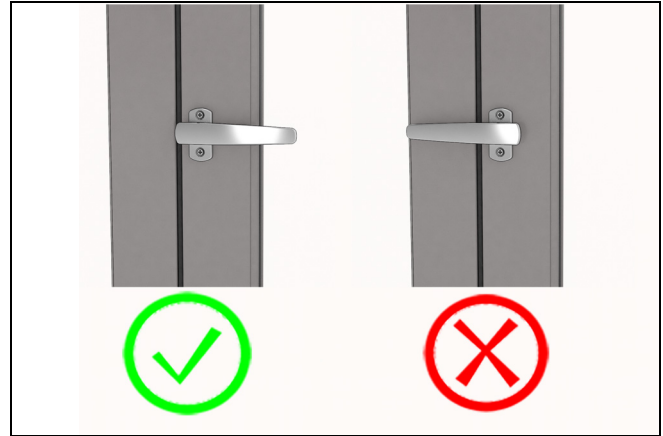

Figure 35

4. When the twin bolt handle is pointed up shown in [Figure 36](#), the bolts should be disengaged/retracted, [Figure 37](#) (unlocked position).



Figure 36

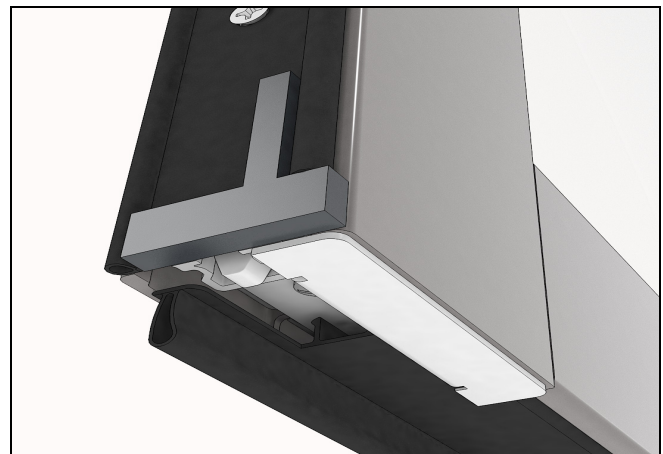

Figure 37

ATTENTION

Avoid closing the panels until all of the panels have been installed and adjusted to avoid damage to the sill.

! CAUTION!

When installing and adjusting panels, use caution to avoid damage to weather stripping. Note which panel sweep weather strip goes with which panel and set aside for later to aid in installation. Also use caution to prevent damage from twin bolt rods contacting weather strip bulb on aluminum head track.

5. Locate the first panel adjacent to the jamb and using a support block, fasten to the hardware numbered 1 or 2, starting on the top and moving down. It is recommended to start with the longer screws if applicable. (Use a screw driver to avoid stripping the screws.) See Figure 38.

NOTE: Some panel weather strips may be held in place with a fastener at each end of the panel. Remove these prior to panel installation.

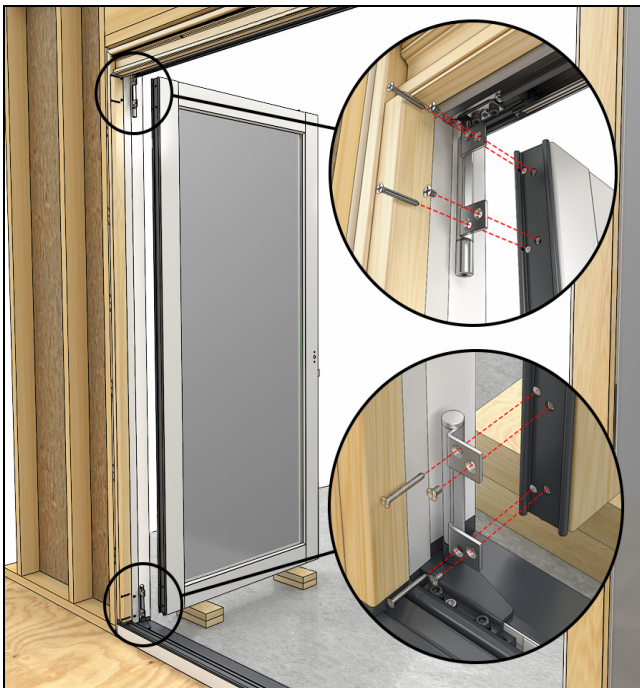

Figure 38

For additional panels, continue reading. Otherwise repeat the process from the other jamb if applicable. Then proceed to step 11.

6. Locate the next panel and, using a support block, fasten it to the previous panel. Fasten the hinge leaves without set screws interfering first. See Figure 39.

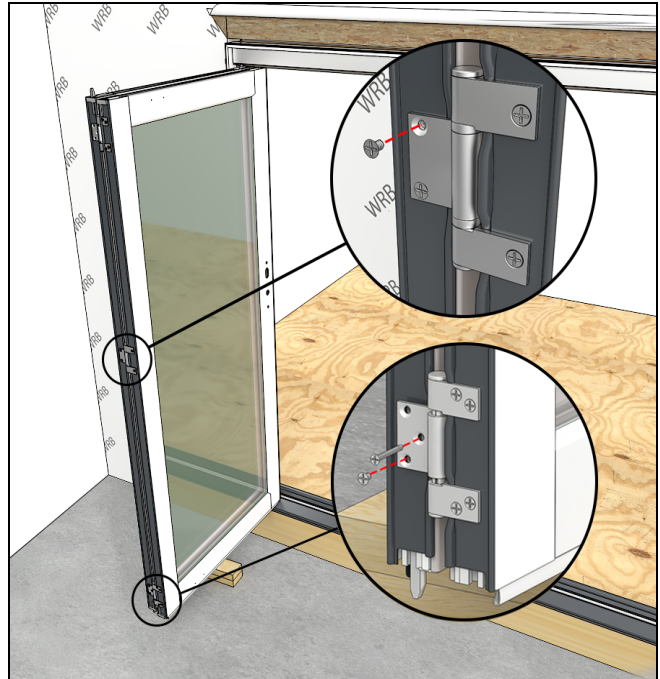

Figure 39

7. Remove the set screw with the provided 3/32" Hex key and fasten the remaining screws. See Figure 40 and Figure 41

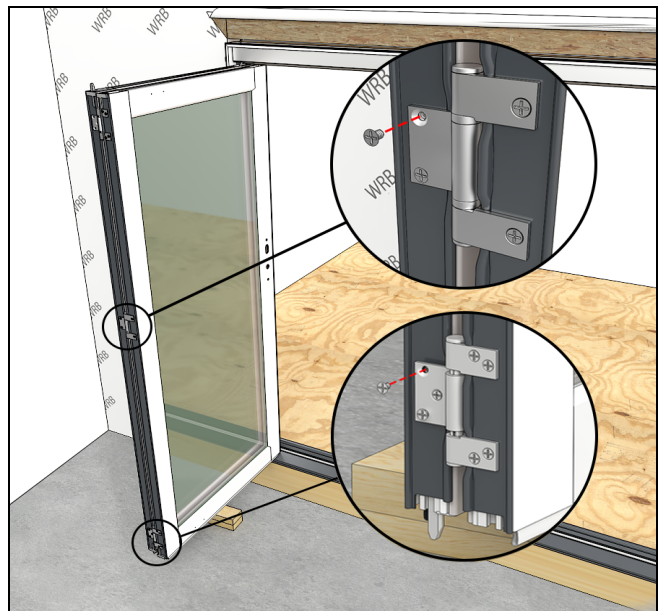

Figure 40

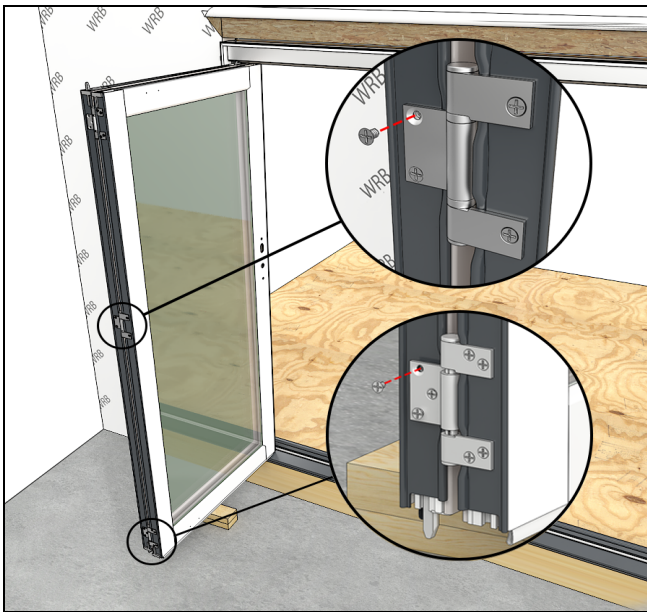

Figure 41

8. Fasten the panel from steps 6 and 7 to the appropriate carrier and guide hardware (Hardware #3, #4, or #5) in the track. Adjust the carrier hardware vertically as needed to align the holes. See Figure 42 and Figure 43.

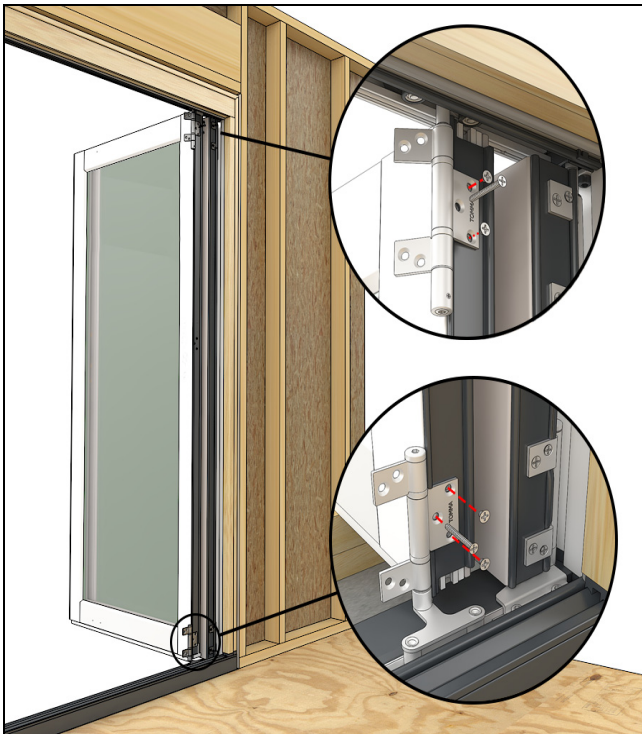

Figure 42

For additional panels, continue reading. Otherwise repeat the process from the other jamb if applicable starting at step 5. Then proceed to step 11.

9. Fasten the middle hinge to the panel. See Figure 43.



Figure 43

1	#10 x 5/16" Machine screws
2	#8 x 1-1/2" Flat head screw

10. Locate the next panel and, using a support block, fasten to the previous panel. See Figure 44 and Figure 45.

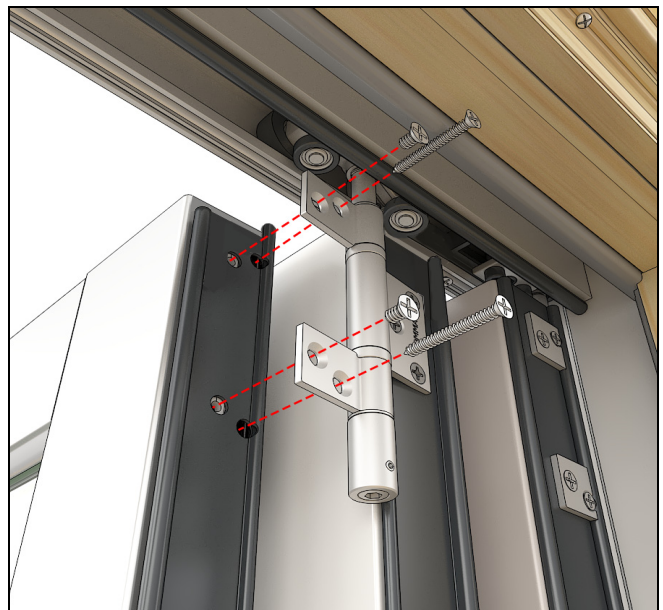

Figure 44

1	#10 x 5/16" Flat head screws
2	#8 x 1-1/2" Flat head screw

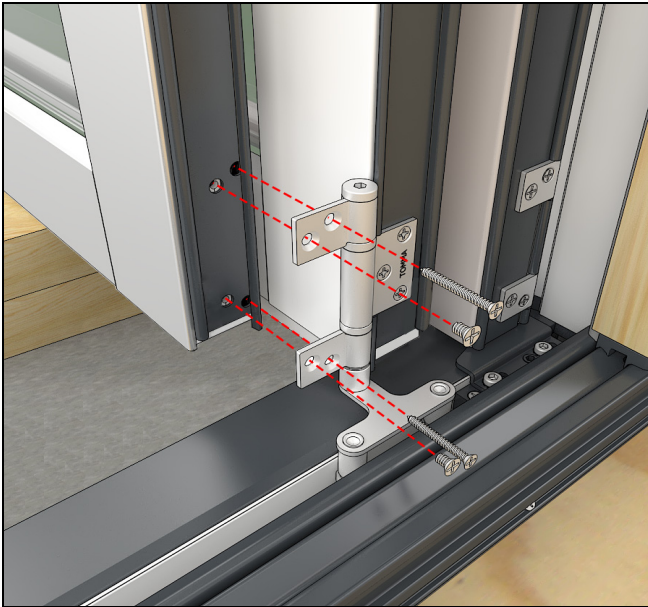

Figure 45

1	#10 x 5/16" Machine screws
2	#8 x 1-1/2" Fat head screw

For additional panels, return to step 6. Otherwise repeat the process from the other jamb if applicable starting at step 5. Then proceed to step 11.

11. Cut the flexible portion of the weather strip above and below every hinge. [See Figure 46.](#)

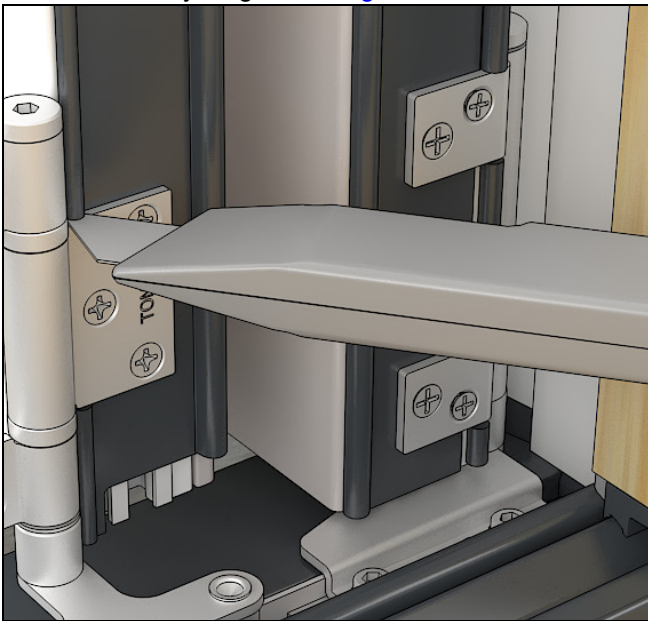

Figure 46

Hardware Adjustments

1. If applicable, raise each of the intermediate and end carriers until there is sufficient weather strip contact at the exterior. Loosen the set screw on each carrier to allow adjustment. Turn the adjustment cam clockwise to raise the panel. After adjusting, tighten the set screw. All hardware set screws should be oriented toward the interior side of the door to prevent access when the door is closed. See [Figure 47](#) and [Figure 48](#).



Figure 47

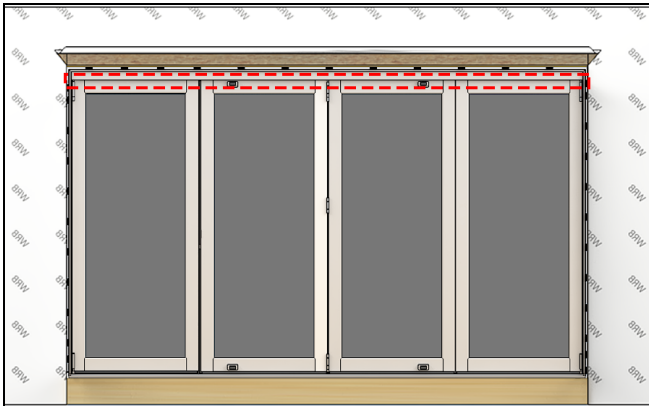

Figure 48

2. Close all the panels. Raise the panels adjacent to the jambs in the same way outlined in step 1. See [Figure 49](#).



Figure 49

3. Adjust the top and bottom pivots horizontally to ensure consistent weather strip contact at the jambs and astragal (if applicable). See [Figure 50](#), [Figure 51](#), and [Figure 52](#).

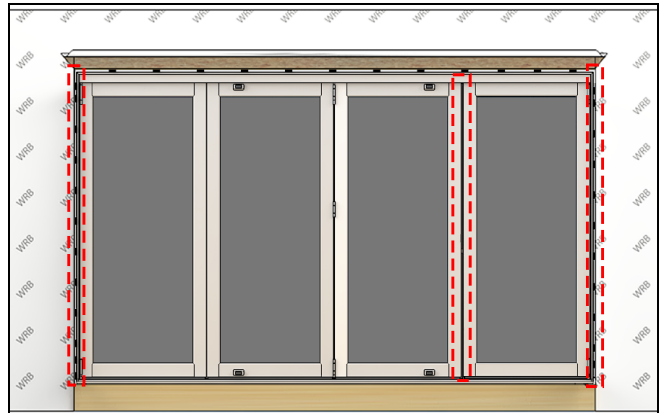

Figure 50

4. The top pivot can be horizontally adjusted through loosening the outer set screws, turning the adjustment cam, and tightening the outer set screws. See [Figure 51](#).



Figure 51

5. The bottom pivot can be adjusted similarly when the panels are open. Loosen the outer set screws, turn the adjustment cam, and tighten the outer set screws. See [Figure 52](#).



Figure 52

Final Component Installation

1. With the door closed, measure the gap from the frame Ultrex to the panel Ultrex and choose the appropriate number of shims. See Figure 53 and Figure 54.

Measurement	# of Shims
< 3/8"	0
3/8" - 1/2"	1
> 1/2"	2



Figure 53

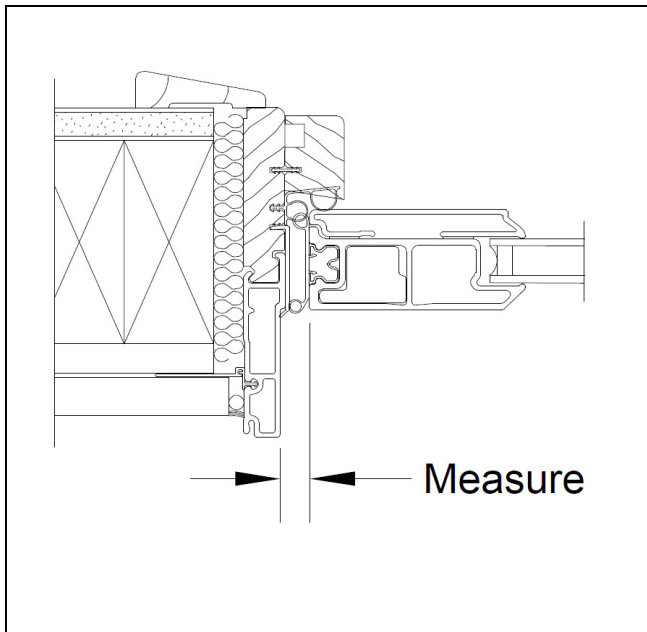

Figure 54

2. Pre-drill through the jamb cover holes with a 1/8" bit. Inject silicone into holes and apply silicone to screw threads. Fasten alignment bolts and correct number of shims from step 1. Repeat on other jamb if applicable. See Figure 55.

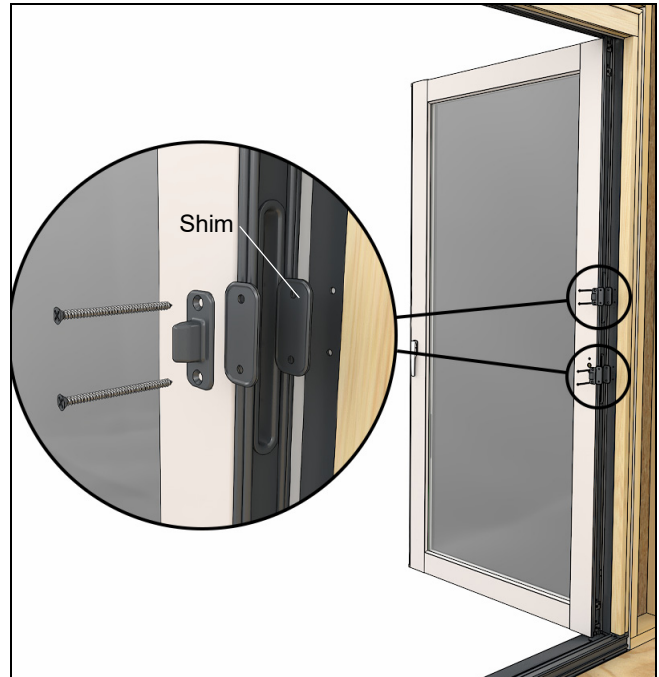

Figure 55

3. Install the head jamb stop cap. See Figure 56.

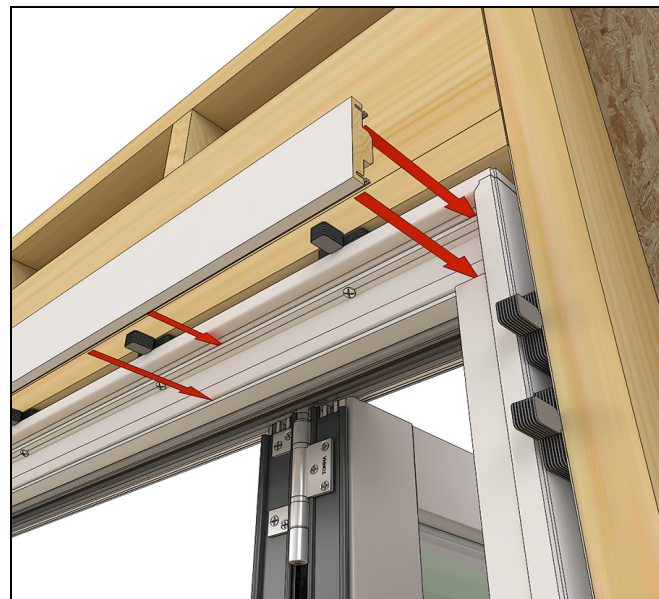

Figure 56

4. Peel the tape backing off the interior sill liner and rotate the liner onto the sill as shown in [Figure 57](#) and [Figure 58](#).

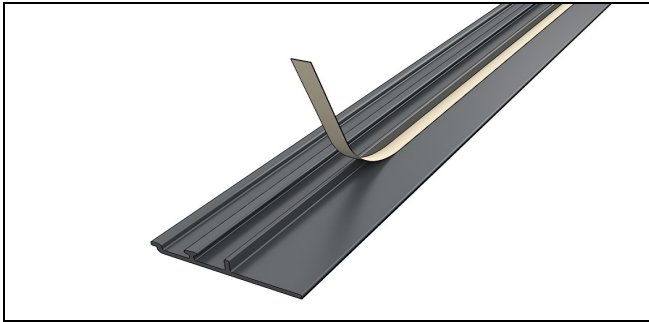

Figure 57

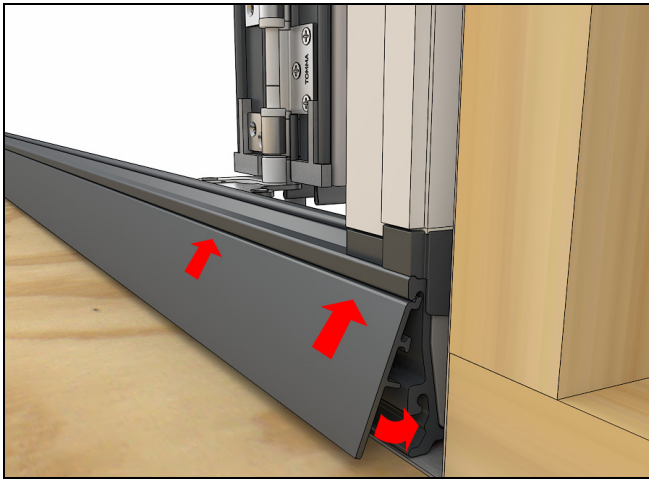

Figure 58

5. Apply the T-gaskets with edges tight to weather strip and flush to panel face as shown in [Figure 59](#), [Figure 60](#) and [Figure 61](#).

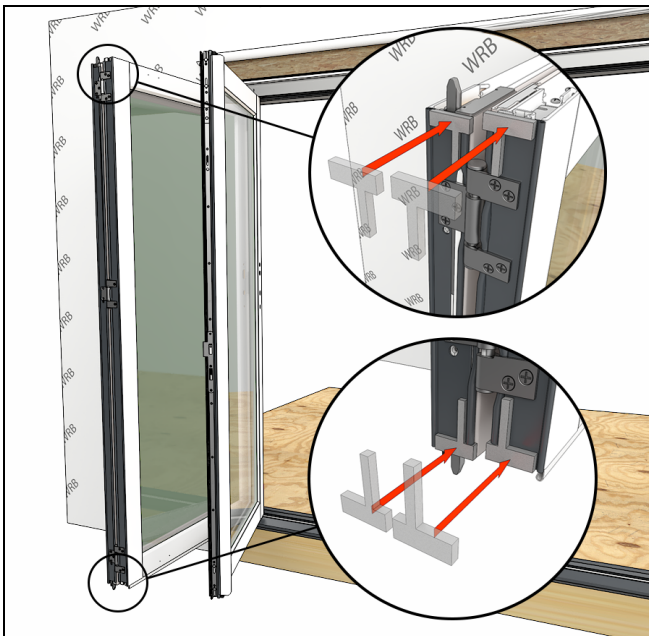

Figure 59

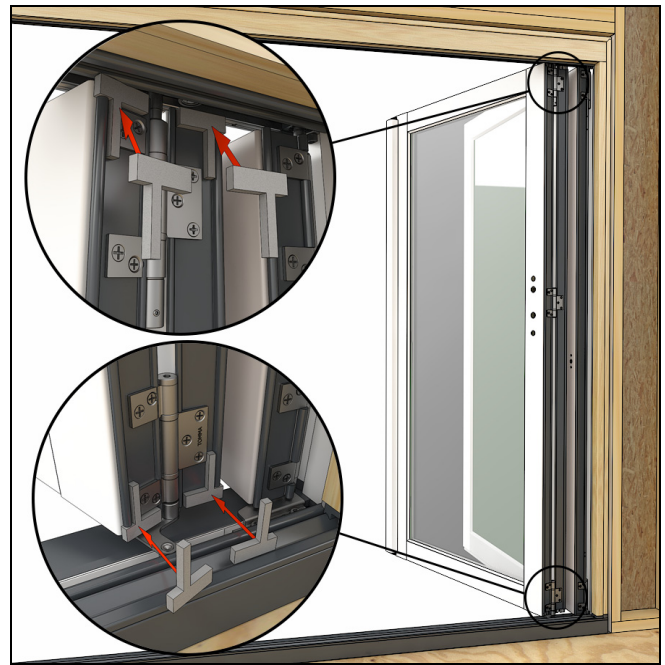

Figure 60

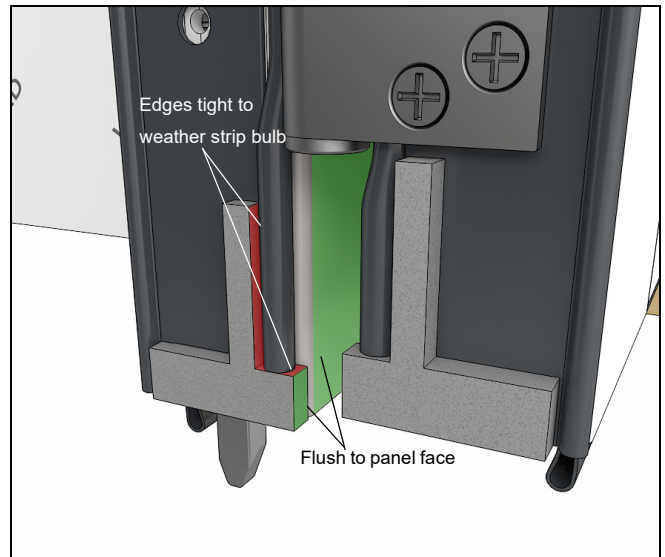

Figure 61

6. For configurations that have a sill strike, install the head jamb strike directly above it in the channel shown in [Figure 62](#) using two #8-18 x 3/4" Pan Heads. Confirm that the location is correct by measuring the distance from one jamb to the edge of the strike and comparing that to the sill strike measurement. If there are screws that impede the installation of the head jamb strike, remove and discard those screws before attaching the strike.

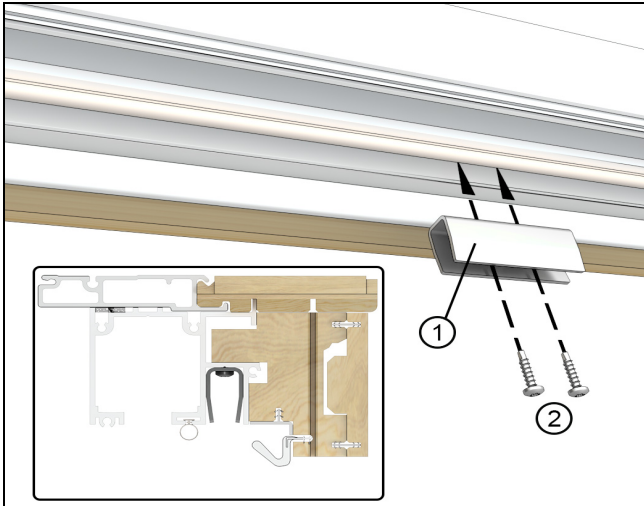

Figure 62

7. Locate any panels with the letter "M" on the end. (ELM for example). Install magnets on the top and bottom of the panels specified in the configuration diagram. [See Figure 63](#). *Note: Verify magnet polarity. IE: The top of the panel should have a North polarity and the adjacent panel that it connects to should have a South polarity causing an attraction effect. If a North Polarity is at the top of both panels, the panels will act like the unit is binding during operation preventing smooth operation.*

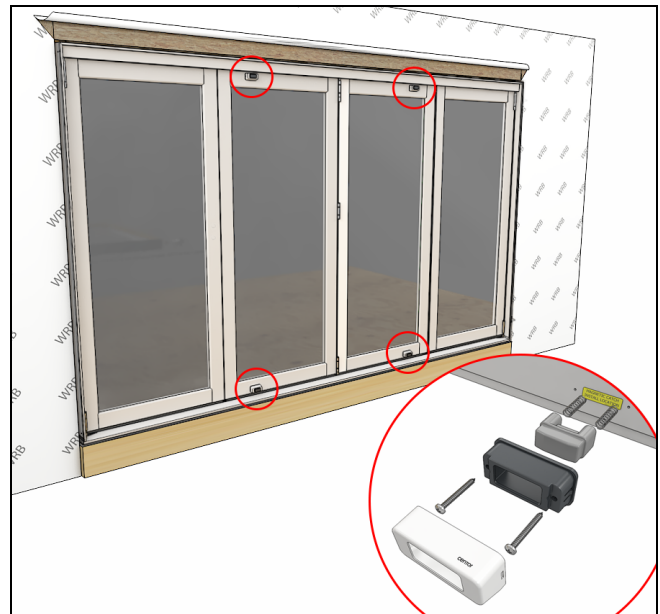

Figure 63

8. Install panel sweeps for each panel. Install the shorter panel sweeps on panels with end carrier or wall pivot hardware. These smaller panel sweeps should be aligned to the panel edge opposite to the end carrier or wall pivot. Other panel sweeps should align to both edges of each panel.

Sill Splicing



To watch a video on this splicing, scan the QR code with your smart phone or similar device or click on this link (<https://vimeo.com/569367322/8bb699a553>)

1. Lay out the sill sections in the correct order. Fasten the sill splice brackets into one side of the sill. Use #8 x 5/8" screws. See Figure 64.



Figure 64

2. Apply sealant along the face of the sill and install alignment pins in the 2 outer holes. Pins should be inserted approximately 1/3 of the way. See Figure 65.

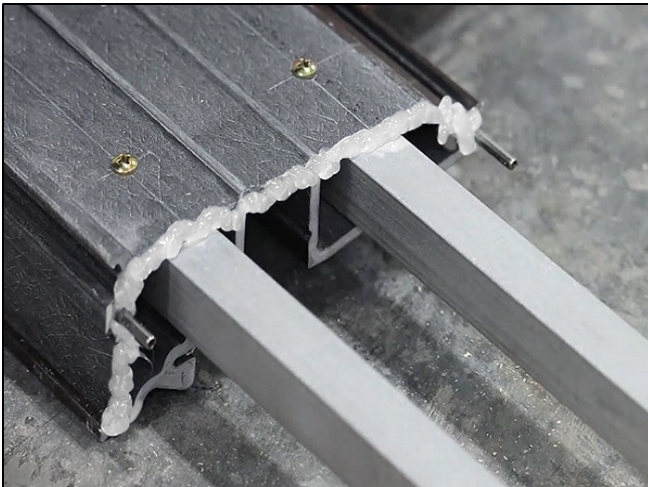

Figure 65

3. Align the sill sections and slide the parts together, ensuring alignment pins are engaged in both splice pieces. See Figure 66.



Figure 66

4. Attach the other section of the sill using the #8 x 5/8 screws. See Figure 67.

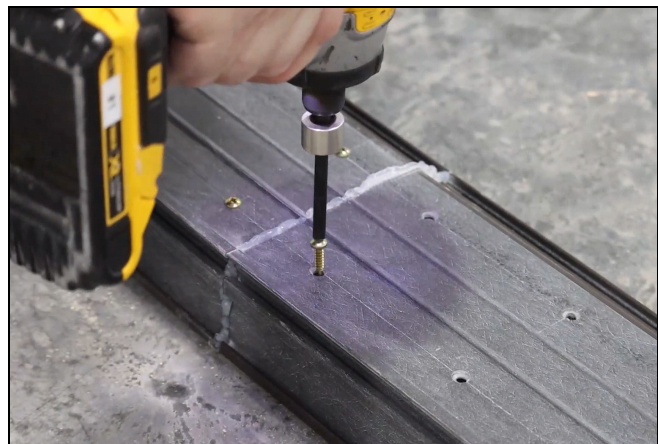

Figure 67

5. Apply sealant over all the screws and remove excess sealant from the sill. See Figure 68



Figure 68

6. Remove small pieces of sill weather strip at each end and discard. See Figure 69.

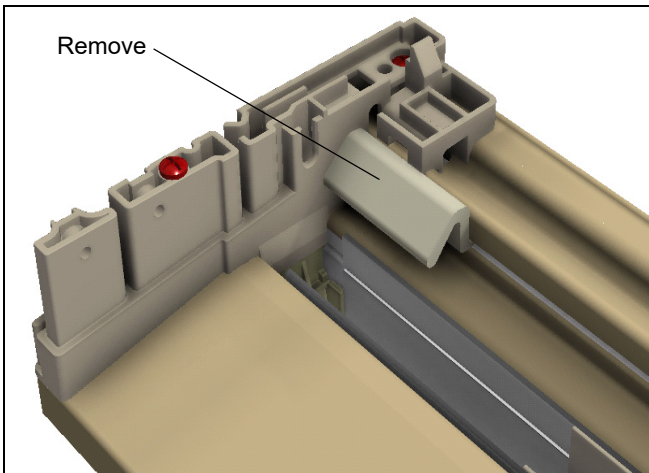

Figure 69

7. Install sill weather strip full length of the spliced sill assembly and cut to fit ensuring weather strip meets both jamb plugs. See Figure 70.

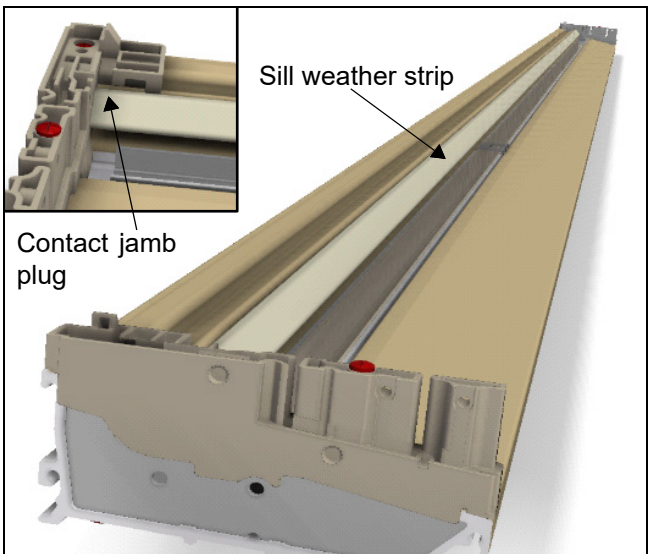

Figure 70

8. Doors with spliced sills will have either 2 or 3 aluminum track pieces. Determine their location and install in the sill. See Figure 71.

- Bi-parting doors (3L3R, 1L5R, 5L1R, 1L6R, 6L1R) will have pre-drilled holes for pivot hardware in two of the aluminum sill tracks. These sill tracks should be installed with the holes located at the ends of the sill. Bi-parting doors with equal panes on each side (3L3R) will have two equal length pieces of aluminum sill track. Other configurations will have the shortest aluminum piece installed on the side with the single panel.

9. Uni-directional doors (6L, 6R, 7L, 7R) will have pre-drilled holes in only one aluminum track and will also be installed with holes at the end of the sill where the pivot hardware will be installed.



Figure 71

10. Doors with spliced sills will have two vinyl insert pieces. Determine their location and install in the sill. See Figure 72

- Bi-parting doors will have the longer piece installed on the side of the door with the sill strike plate, and the shorter piece installed on the opposite end.
- Uni-directional doors shall have the vinyl inserts located similar to the aluminum tracks, with the short vinyl piece near the short aluminum piece.
- Vinyl insert lengths are slightly different than the aluminum track lengths so the seams are staggered after installing. Vinyl inserts will be offset approximately 4" from sill ends where pivot hardware will be installed. Actual offset for hardware clearance can be adjusted later when hardware is installed.

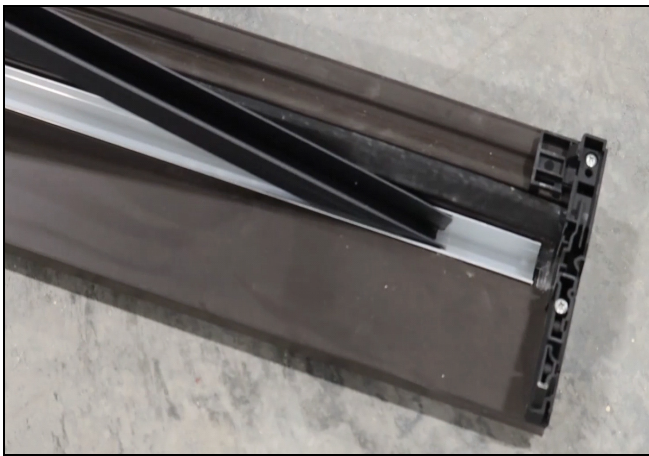

Figure 72

11. If applicable, install the sill strike plate. See [Figure 73](#)



Figure 73

Head Jamb Splicing

1. Insert and fasten the head jamb keys in the section that does not have the aluminum track exposed. See [Figure 74](#).

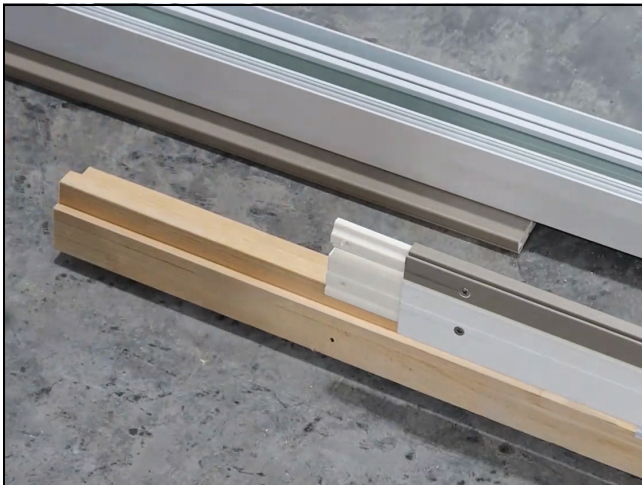

Figure 74

2. Place this section against a hard surface separated by a wooden block to prevent damage to the mitered end. See [Figure 75](#).



Figure 75

3. Tap the pins in the 2 exterior holes in the aluminum track. Pins should be inserted approximately 1/3 of the way. See [Figure 76](#).

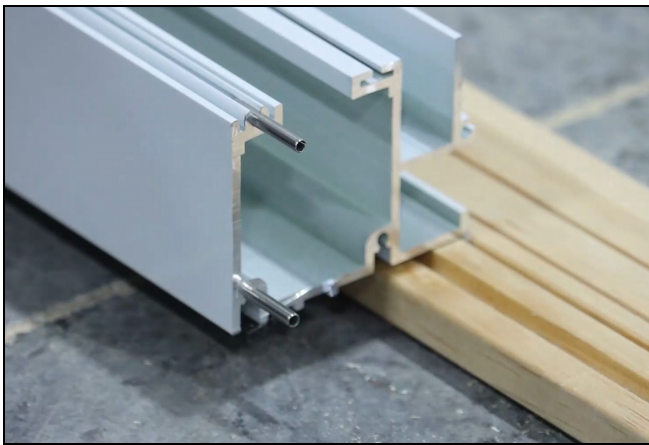

Figure 76

4. Apply sealant to the head jamb Ultrex face on section without keys. See Figure 77.



Figure 77

5. Slide the 2 sections together, once the pins engage use a mallet and wood block to connect the two sub-assemblies. Make sure the pins align and are engaged in both pieces of head track. To prevent damage to the aluminum track, avoid using a mallet on the end with the hardware access cutout. See Figure 78



Figure 78

6. Fasten the other head jamb key screws. See Figure 79.

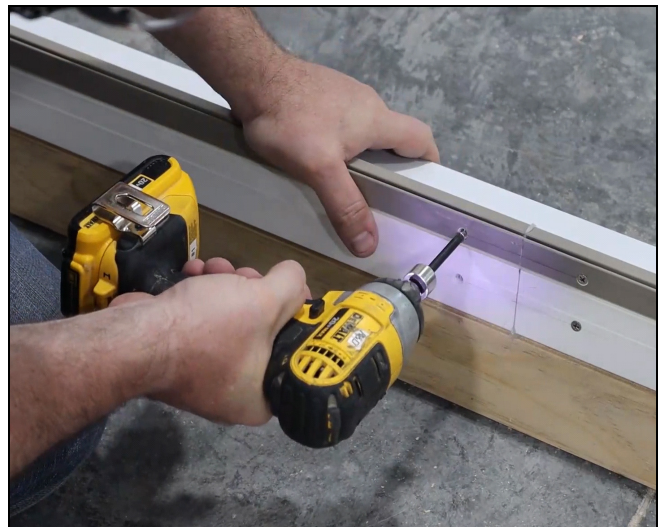

Figure 79

7. Apply sealant to the splice seam and over all the screws and remove excess sealant from the head jamb. See Figure 80.



Figure 80

8. Insert the T-Slot weather strip into the aluminum track on the access hole side and slide it down to the other end of the track. It should terminate at the first screw hole at the opposite end of the track or the end of the track if there are no holes. Cut to fit. [See Figure 81](#) and [Figure 82](#).



Figure 81

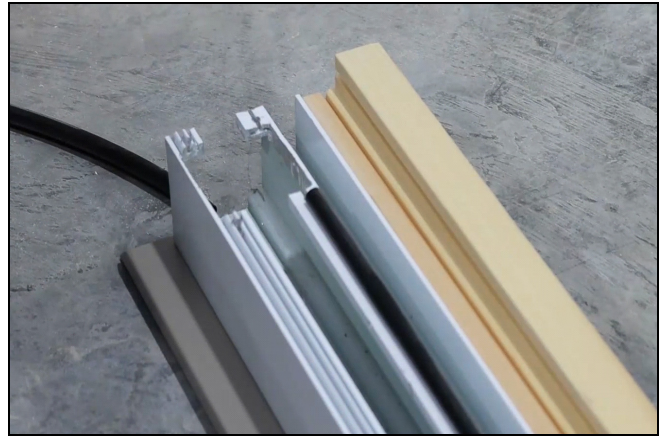

Figure 82

9. Attach head jamb cover pieces flush to the end of the wood head jamb. Both pieces are the same length. [See Figure 83](#)



Figure 83

10. Install the head jamb weather strip full length of the wood head jamb and cut to fit ensuring the weather strip is flush to both ends. [See Figure 84](#)

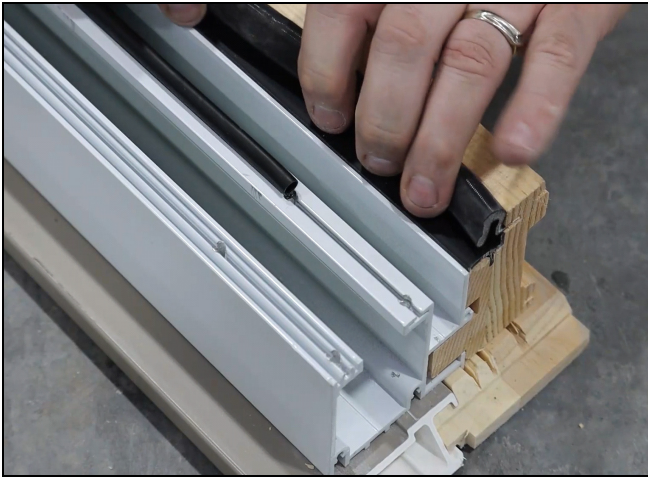

Figure 84

11. Fasten any short head jamb screws into the wood head jamb near the splice. [See Figure 85](#)



Figure 85

12. Return to the Frame Assembly instructions found at the beginning.

Technical Installation Specifications

The following details are specified for proper installation and performance of the Marvin Door.

- Rough Opening Width: 1/4"-1" (6-25) wider than door frame outside measurement.
- Rough Opening Height: 1/4"-1/2" (6-13) higher than door frame outside measurement.
- Masonry Opening Width: 1/4"-1/2" (6-13) wider than door frame outside measurement.
- Masonry Opening Height: 1/8"-1/4" (3-6) higher than door frame outside measurement.
- Properly flash and/or seal all doors at the exterior perimeter.
- Sealants used for installation must be Grade NS Class 25 per ASTM C920 and compatible with the building exterior, door exterior surface, and flashing/water management materials.
- Construction adhesive must be APA rated AFG-01 SPEC.
- Flashing materials must comply with ASTM E2112-07, section 5.13 and be compatible with all materials used in installation including panning systems, air barriers and building papers, sheathing, and the door unit.
- The following materials were used to develop these instructions:

Weather Resistant Barriers: DuPont™ Tyvek® Home-Wrap or Grade D building paper.

Flashing Materials: DuPont™ FlexWrap or DuPont™ Straight Flash, DuPont™ Tyvek® Tape.

Sealant: OSI® Quad Pro-Series®; solvent release butyl rubber sealant or DAP DynaFlex230™.

- Optional foams used for installation must be low expansion only. Foam and foam application must comply with ASTM E2112-07, SEC 5.9.2.
- Fasteners penetrating chemically treated lumber must be a minimum of 0.90 oz/ft² zinc hot dipped galvanized or stainless steel type 304 or 316.
- Shim 4"-6" (102-152) from each corner, and at every point of attachment.

Elevate Bi-Fold Installer and Customer Parts List

	Hinge Color	Part Number	1L	1R	2L	2R	3L	3R	4L	4R	5L	5R	2L1R	1L2R	3L1R	1L3R	4L1R	1L4R	1L1R LH	1L1R RH	2L2R	3L3R RH	3L3R LH	5L1R	1L5R	6L	6R	6L1R	1L6R	7L	7R	
Magnet	SS	11863220	-	-	-	-	QTY 2	QTY 2	QTY 2	QTY 2	QTY 4	QTY 4	-	-	QTY 2	QTY 2	QTY 2	QTY 2	-	-	-	QTY 4	QTY 4	QTY 4	QTY 4	QTY 4	QTY 4	QTY 4	QTY 4	QTY 6	QTY 6	
	BK	11863221	-	-	-	-	QTY 2	QTY 2	QTY 2	QTY 2	QTY 4	QTY 4	-	-	QTY 2	QTY 2	QTY 2	QTY 2	-	-	-	QTY 4	QTY 4	QTY 4	QTY 4	QTY 4	QTY 4	QTY 4	QTY 4	QTY 6	QTY 6	
Twin Bolt Handle	SS	11861994	-	-	QTY 1	QTY 1	QTY 1	QTY 1	QTY 2	QTY 2	QTY 2	QTY 2	QTY 1	QTY 1	QTY 1	QTY 1	QTY 2	QTY 2	-	-	QTY 2	QTY 2	QTY 2	QTY 2	QTY 2	QTY 3	QTY 3	QTY 3	QTY 3	QTY 3	QTY 3	
	BK	11861995	-	-	QTY 1	QTY 1	QTY 1	QTY 1	QTY 2	QTY 2	QTY 2	QTY 2	QTY 1	QTY 1	QTY 1	QTY 1	QTY 2	QTY 2	-	-	QTY 2	QTY 2	QTY 2	QTY 2	QTY 2	QTY 3	QTY 3	QTY 3	QTY 3	QTY 3	QTY 3	
Twin Bolt Handle Screws	SS	11861988	-	-	QTY 2	QTY 2	QTY 2	QTY 2	QTY 4	QTY 4	QTY 4	QTY 4	QTY 2	QTY 2	QTY 2	QTY 2	QTY 4	QTY 4	-	-	QTY 4	QTY 4	QTY 4	QTY 4	QTY 4	QTY 6	QTY 6	QTY 6	QTY 6	QTY 6	QTY 6	
	BK	11861989	-	-	QTY 2	QTY 2	QTY 2	QTY 2	QTY 4	QTY 4	QTY 4	QTY 4	QTY 2	QTY 2	QTY 2	QTY 2	QTY 4	QTY 4	-	-	QTY 4	QTY 4	QTY 4	QTY 4	QTY 4	QTY 6	QTY 6	QTY 6	QTY 6	QTY 6	QTY 6	
Wall Pivot RH	SS	11861902	-	QTY 1	-	QTY 1	-	QTY 1	-	QTY 1	-	QTY 1	QTY 1	QTY 1	QTY 1	QTY 1	QTY 1	QTY 1	QTY 1	QTY 1	QTY 1	QTY 1	QTY 1	QTY 1	QTY 1	QTY 1	-	QTY 1	QTY 1	QTY 1	-	QTY 1
	BK	11861904	-	QTY 1	-	QTY 1	-	QTY 1	-	QTY 1	-	QTY 1	QTY 1	QTY 1	QTY 1	QTY 1	QTY 1	QTY 1	QTY 1	QTY 1	QTY 1	QTY 1	QTY 1	QTY 1	QTY 1	QTY 1	-	QTY 1	QTY 1	QTY 1	-	QTY 1
Wall Pivot LH	SS	11861901	QTY 1	-	QTY 1	-	QTY 1	-	QTY 1	-	QTY 1	-	QTY 1	QTY 1	QTY 1	QTY 1	QTY 1	QTY 1	QTY 1	QTY 1	QTY 1	QTY 1	QTY 1	QTY 1	QTY 1	QTY 1	-	QTY 1	QTY 1	QTY 1	-	QTY 1
	BK	11861903	QTY 1	-	QTY 1	-	QTY 1	-	QTY 1	-	QTY 1	-	QTY 1	QTY 1	QTY 1	QTY 1	QTY 1	QTY 1	QTY 1	QTY 1	QTY 1	QTY 1	QTY 1	QTY 1	QTY 1	QTY 1	-	QTY 1	QTY 1	QTY 1	-	QTY 1
Intermediate Carrier	SS	11861970	-	-	-	-	QTY 1	QTY 1	QTY 1	QTY 1	QTY 2	QTY 2	-	-	QTY 1	QTY 1	QTY 1	QTY 1	-	-	-	QTY 2	QTY 2	QTY 2	QTY 2	QTY 2	QTY 2	QTY 2	QTY 2	QTY 3	QTY 3	
	BK	11861971	-	-	-	-	QTY 1	QTY 1	QTY 1	QTY 1	QTY 2	QTY 2	-	-	QTY 1	QTY 1	QTY 1	QTY 1	-	-	-	QTY 2	QTY 2	QTY 2	QTY 2	QTY 2	QTY 2	QTY 2	QTY 2	QTY 3	QTY 3	
End Carrier RH	SS	11861932	-	-	QTY 1	-	-	-	QTY 1	-	-	-	QTY 1	-	-	-	QTY 1	-	-	-	QTY 1	-	-	-	-	QTY 1	-	QTY 1	-	-	-	
	BK	11861934	-	-	QTY 1	-	-	-	QTY 1	-	-	-	QTY 1	-	-	-	QTY 1	-	-	-	QTY 1	-	-	-	-	QTY 1	-	QTY 1	-	-	-	
End Carrier LH	SS	11861931	-	-	-	QTY 1	-	-	-	QTY 1	-	-	-	QTY 1	-	-	-	QTY 1	-	-	QTY 1	-	-	-	-	-	QTY 1	-	QTY 1	-	-	
	BK	11861933	-	-	-	QTY 1	-	-	-	QTY 1	-	-	-	QTY 1	-	-	-	QTY 1	-	-	QTY 1	-	-	-	-	-	QTY 1	-	QTY 1	-	-	
Alignment Bolt Kit	BK	150005	QTY 1	QTY 1	QTY 2	QTY 2	QTY 1	QTY 1	QTY 2	QTY 2	QTY 1	QTY 1	QTY 2	QTY 2	QTY 2	QTY 2	QTY 2	QTY 2	QTY 2	QTY 2	QTY 3	QTY 2	QTY 2	QTY 2	QTY 2	QTY 2	QTY 2	QTY 2	QTY 2	QTY 2	QTY 1	QTY 1
Operator Install Kit	N/A	10188190	QTY 1	QTY 1	QTY 1	QTY 1	QTY 1	QTY 1	QTY 1	QTY 1	QTY 1	QTY 1	QTY 1	QTY 1	QTY 1	QTY 1	QTY 1	QTY 1	QTY 1	QTY 1	QTY 1	QTY 1	QTY 1	QTY 1	QTY 1	QTY 1	QTY 1	QTY 1	QTY 1	QTY 1	QTY 1	QTY 1
Frame Assembly Kit	N/A	10188192	QTY 1	QTY 1	QTY 1	QTY 1	QTY 1	QTY 1	QTY 1	QTY 1	QTY 1	QTY 1	QTY 1	QTY 1	QTY 1	QTY 1	QTY 1	QTY 1	QTY 1	QTY 1	QTY 1	QTY 1	QTY 1	QTY 1	QTY 1	QTY 1	QTY 1	QTY 1	QTY 1	QTY 1	QTY 1	QTY 1
Exterior Panel Hardware Kit	SS	10188193	QTY 2	QTY 2	QTY 3	QTY 3	QTY 4	QTY 4	QTY 5	QTY 5	QTY 6	QTY 6	QTY 4	QTY 4	QTY 5	QTY 5	QTY 6	QTY 6	QTY 3	QTY 3	QTY 5	QTY 7	QTY 7	QTY 7	QTY 7	QTY 7	QTY 7	QTY 7	QTY 8	QTY 8	QTY 8	QTY 8
	BK	10188194	QTY 2	QTY 2	QTY 3	QTY 3	QTY 4	QTY 4	QTY 5	QTY 5	QTY 6	QTY 6	QTY 4	QTY 4	QTY 5	QTY 5	QTY 6	QTY 6	QTY 3	QTY 3	QTY 5	QTY 7	QTY 7	QTY 7	QTY 7	QTY 7	QTY 7	QTY 7	QTY 8	QTY 8	QTY 8	QTY 8
Interior Panel Hardware Kit	SS	10188195	-	-	QTY 3	QTY 3	QTY 3	QTY 3	QTY 5	QTY 5	QTY 5	QTY 5	QTY 3	QTY 3	QTY 3	QTY 3	QTY 5	QTY 5	-	-	QTY 5	QTY 5	QTY 5	QTY 5	QTY 5	QTY 7	QTY 7	QTY 7	QTY 7	QTY 7	QTY 7	
	BK	10188196	-	-	QTY 3	QTY 3	QTY 3	QTY 3	QTY 5	QTY 5	QTY 5	QTY 5	QTY 3	QTY 3	QTY 3	QTY 3	QTY 5	QTY 5	-	-	QTY 5	QTY 5	QTY 5	QTY 5	QTY 5	QTY 7	QTY 7	QTY 7	QTY 7	QTY 7	QTY 7	
Splicing Kit	N/A	10188197	-	-	-	-	-	-	-	-	-	-	-	-	-	-	-	-	-	-	-	QTY 1	QTY 1	QTY 1	QTY 1	QTY 1	QTY 1	QTY 1	QTY 1	QTY 1	QTY 1	
Panel Edge Gasket	LH	10501029	QTY 2	QTY 2	QTY 4	QTY 4	QTY 6	QTY 6	QTY 8	QTY 8	QTY 10	QTY 10	QTY 6	QTY 6	QTY 8	QTY 8	QTY 10	QTY 10	QTY 4	QTY 4	QTY 8	QTY 12	QTY 12	QTY 12	QTY 12	QTY 12	QTY 12	QTY 12	QTY 12	QTY 12	QTY 12	QTY 12
	RH	10501030	QTY 2	QTY 2	QTY 4	QTY 4	QTY 6	QTY 6	QTY 8	QTY 8	QTY 10	QTY 10	QTY 6	QTY 6	QTY 8	QTY 8	QTY 10	QTY 10	QTY 4	QTY 4	QTY 8	QTY 12	QTY 12	QTY 12	QTY 12	QTY 12	QTY 12	QTY 12	QTY 12	QTY 12	QTY 12	QTY 12
Strike Plate (Frame)	LH	10188200	-	QTY 1	-	-	-	QTY 1	-	-	-	QTY 1	-	-	-	-	-	-	-	-	-	-	-	-	-	-	QTY 1	-	-	-	QTY 1	
	RH	10188201	QTY 1	-	-	-	QTY 1	-	-	-	QTY 1	-	-	-	-	-	-	-	-	-	-	-	-	-	-	QTY 1	-	-	-	QTY 1	-	
Installation Instructions	N/A	19916325	QTY 1	QTY 1	QTY 1	QTY 1	QTY 1	QTY 1	QTY 1	QTY 1	QTY 1	QTY 1	QTY 1	QTY 1	QTY 1	QTY 1	QTY 1	QTY 1	QTY 1	QTY 1	QTY 1	QTY 1	QTY 1	QTY 1	QTY 1	QTY 1	QTY 1	QTY 1	QTY 1	QTY 1	QTY 1	QTY 1
Configuration Diagram	N/A	Config Dependent	19916339	19916346	19916340	19916347	19916341	19916348	19916342	19916349	19916343	19916350	19916353	19916358	19916354	19916359	19916355	19916360	19916363	19916364	19916365	19916367	19916366	19916356	19916361	19916344	19916351	19916357	19916362	19916345	19916352	

