

Elevate Casement WOCD

Field Applied Instructions

Failure to follow these instructions may result in the window opening control devices (WOCDs) being ineffective in controlling the window opening.

A copy of the safety information shall be provided to the owner of the building in which the window opening control device (WOCD) is installed and to the occupant in the dwelling where the opening control device is installed (or is to be installed).

NOTE: This instruction is for Elevate Casement (ELCA) and Elevate Casement Narrow Frame (ELCANF). When installed and used as directed, the Window Opening Control Device meets the requirements of ASTM F2090-17.

Building and fire codes shall be consulted before installing WOCDs. Contact local building code department or fire department for specific applicable codes and install in accordance.

The casement WOCD is not applicable for use in coastal applications.

Follow manufacturer's assembly and installation instructions carefully. Failure to do so may result in accidental window falls.



WARNING!

Possible Fall Hazard

- Young children may fall out of the window if the window opening control device (WOCD) is not installed correctly.
- Install the device so that a rigid 4.0-in. (102mm) diameter sphere does not pass through any space at the lowest opening portion in the window opening after the WOCD is in place.
- Young children may fall out of the window if all installation instructions are not followed.
- Use recommended materials and techniques.
- Make sure that the WOCD is securely installed in accordance with manufacturer's instructions.
- Make sure that the window frame is in good condition.

NOTE: Once installation of unit is complete, check WOCD for proper operation and then close securely. To re-engage the WOCD, close the sash completely and lock the window and check for operability.

Minimum and Maximum sizes				
Unit	Frame Size Width		Frame Size Height	
	Min	Max	Min	Max
ELCA	17.844 (453)	36.000 (914)	31.125 (791)	71.125 (1807)
ELCANF	17.844 (453)	36.000 (914)	24.000 (610)	71.125 (1807)

Required Tools:

- Flat pry bar
- Pliers
- Tether spring clamp
- WOCD frame jig (ELCA)
- Phillips screwdriver (No. 2)
- 7/64" drill bit and drill (long preferred)
- WOCD sash jig (ELCA)
- T20 Torx bit and driver (long preferred): 3/16" diam. shaft
- F18 x 1.250" brad nailer or hammer/punch (ELCA only)

Parts needed or to be replaced:

- Head jamb, sill, and locking-side jamb stop/covers with WOCD fabrications. For kit details, refer to Table 1.

Part No.	Description	Qty	Notes
19916123	Field Installation Instructions	1	
19916102	Hang Tag	1	
19972239	Safety Information	2	One for owner, one for occupant
11718011	WOCD Sticker	1	
10502999	Casement WOCD Tether Assembly	1	Available in beige only
	Casement WOCD Locking Assembly	1	Color dependent
11881120	#8-15 x 1.500" Flathead Screw	2	
11806251	#8-18 x 0.750" Torx T20 Screw, AB	2	

Table 1: Field-applied WOCD kit details

Field-Applied Install Process

IMPORTANT

Inspect all fabrication jigs before and after each use. Ensure bushings are not loose and do not show heavy wear. Inspect all jamb stops, jamb covers, and hardware covers for damage. Contact Customer Support if a replacement is needed.

1. Open the window completely.
2. For ELCA/ELCANF, use a flat pry bar to carefully remove the sill and head jamb stops/covers from the exterior. Remove the jamb stop/covers on the locking side from the exterior.
3. Using pliers, remove any remaining brad nails protruding from the frame (ELCA only).
4. Use a Phillips screwdriver to remove the locking mechanism from the jamb.
5. Using a flat pry bar, detach the sill weatherstrip starting from the locking-side jamb. Detach the locking-side jamb weatherstrip starting from the sill.
6. Place frame jig on exterior sill and place tight against the locking-side jamb. Apply constant pressure to avoid jig movement while drilling. See [Figure 1](#) and [Figure 2](#).

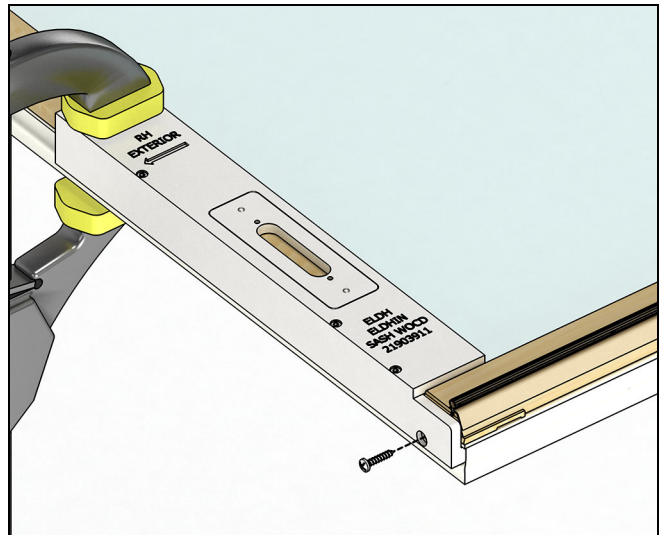

Figure 1 Frame prepared to be drilled.

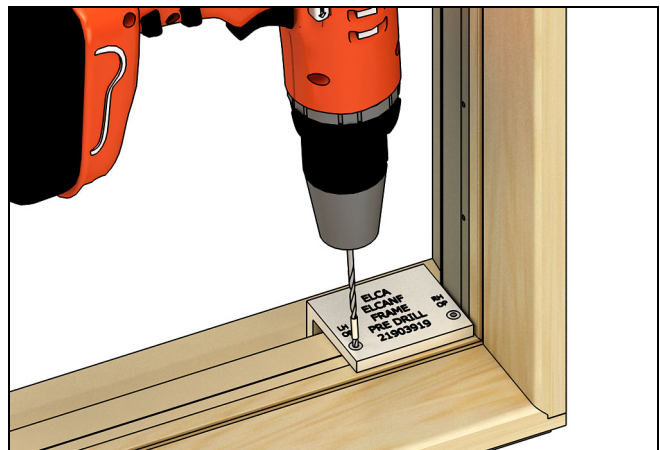

Figure 2 Proper frame jig placement.

7. With the frame jig in place, drill two 7/64" diameter holes through the first wall of Ultrex. To prevent marring the jamb, use the long drill bit or a flexible bit extension.

8. Reattach the sill and locking-side jamb weather strips.

9. Position the WOCD housing so the lock lever is closest to the locking-side jamb. See Figure 3.

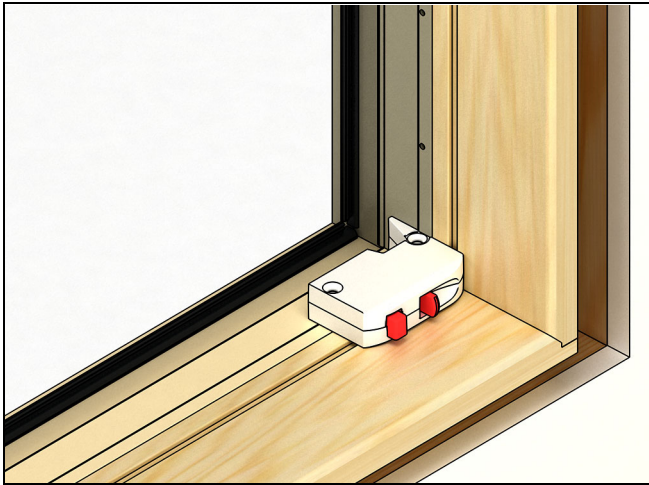

Figure 3 WOCD housing positioning.

10. With a manual Phillips driver, carefully attach the WOCD housing to the sill with two #8-15 x 1.500" flathead screws taking caution to avoid stripping the screws.

11. Reattach the locking mechanism.

12. Remove the sash from the frame and lay sash on a flat, non-scratch surface with the interior facing up.

13. As shown in Figure 4, hold the sash jig on the lower, locking-side corner of the sash and drill two 7/64" holes. Drill through the wood hoop and first wall of Ultrex.

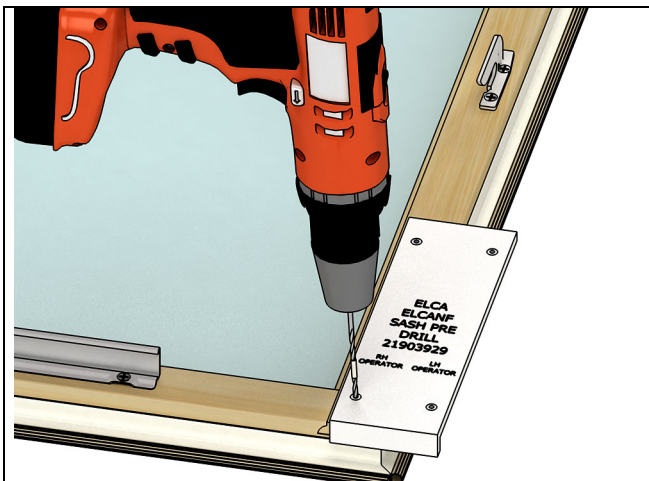

Figure 4 Firmly hold sash jig on corner of sash.

14. Using a T20 Torx bit and driver, attach the tether plug to the sash with a #8-18 x 3/4" Torx T20 screw. See Figure 5.

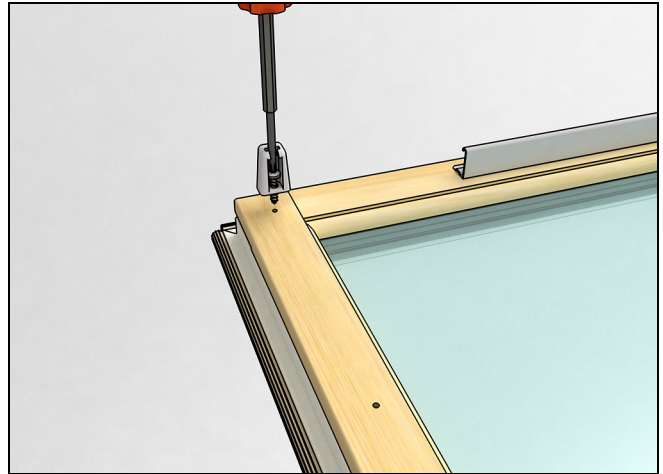

Figure 5 Correct orientation of tether plug.

15. Attach the tether housing by swinging into tether plug.

- Pull tether spring back and hold with tether spring clamp. See Figure 6 and Figure 7.

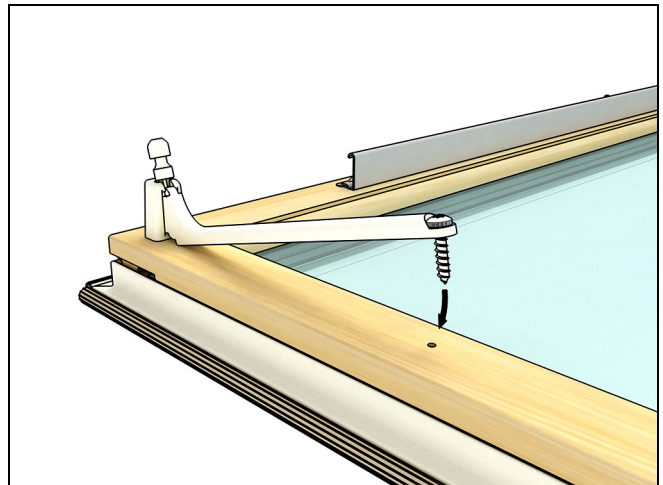

Figure 6 Swing housing into plug while holding spring.

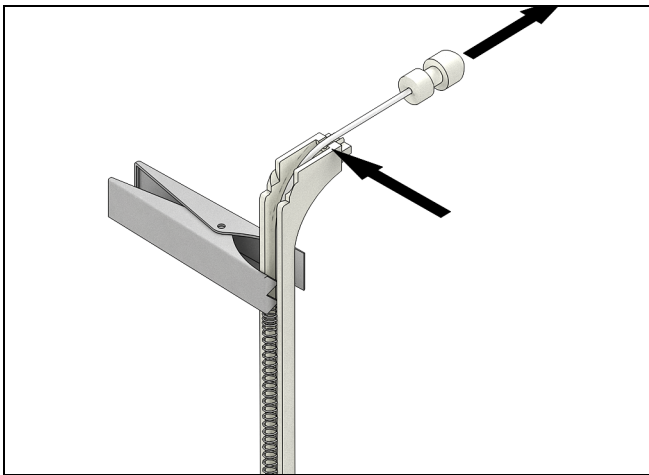

Figure 7 Hold tether spring with tether spring clamp.

- Be sure the tether spring does not extend past the point shown in [Figure 8](#).

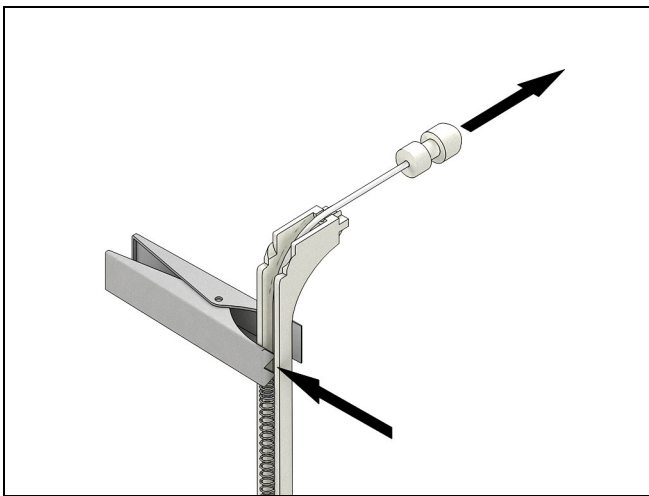

Figure 8 Firmly hold sash jig on corner of sash.

- Using a T20 Torx bit and driver, fasten the tether housing to the sash with a #8-18 x 3/4" Torx T20 screw.
- Pull and release the locking bullet to ensure the spring is properly placed and functioning.
- If the locking bullet does not retract quickly and completely, repeat Step 16 through Step 18. If the spring functions properly, ensure the installed tether assembly resembles [Figure 9](#).

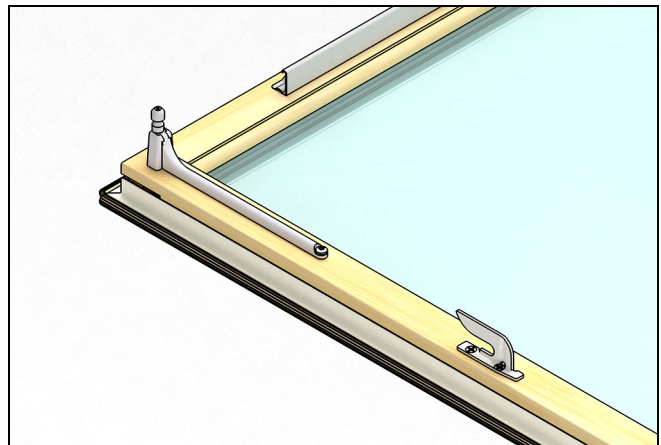

Figure 9 Properly installed WOCD tether assembly.

- Reattach the sash to the frame.
- Carefully place the new WOCD-fabricated jamb stop/cover on the locking-side jamb.
- Carefully place the new WOCD-fabricated head jamb stop/cover and sill/hardware cover onto the sill and head jamb.
- For ELCA only use a brad nailer or a hammer and a nail set to fasten the locking-side jamb stop to the frame using F18 X 1.250" brad nails spaced 8" – 12" apart and 3" – 5" off end. Place and fasten the head jamb stop and hardware cover to frame. For ELCANF, place and press the locking-side jamb cover into position. Place and press the head jamb and sill covers.
- To reengage the WOCD, close the sash completely and lock the window and check for operability.
- Verify the WOCD functions properly five times.
 - Leave WOCD engaged and open the sash to the WOCD-governed limit to verify the WOCD stays tethered.
 - Close the sash.
 - On the WOCD lock housing, slide the lock lever and push the lock button while opening the sash.
 - Verify the WOCD disengages by opening the sash beyond the WOCD-governed limit.
 - Close the sash to re-engage the WOCD and repeat process.
- Disengage the WOCD and open the sash to place the WOCD sticker:
 - For all ELCA/ELCANF, clean the exterior sill Ultrex and place the WOCD sticker on the exterior sill Ultrex in line with the hinge track, readable from the interior, 2" to 3" from the locking-side jamb. See [Figure 10](#).

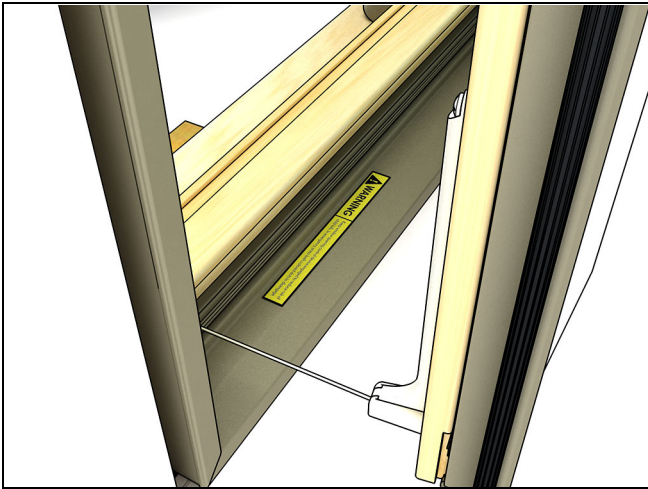

Figure 10 Place the WOOD sticker on clean exterior sill Ultrex.

26. Close the sash and re-engage the WOOD. Slightly open the sash to verify the WOOD is engaged. Close the sash.

27. Ensure the finished product resembles [Figure 11](#).



Figure 11 Completed casement unit with WOOD.