

Essential Polygon and Round Top

Installation and Finishing Instructions

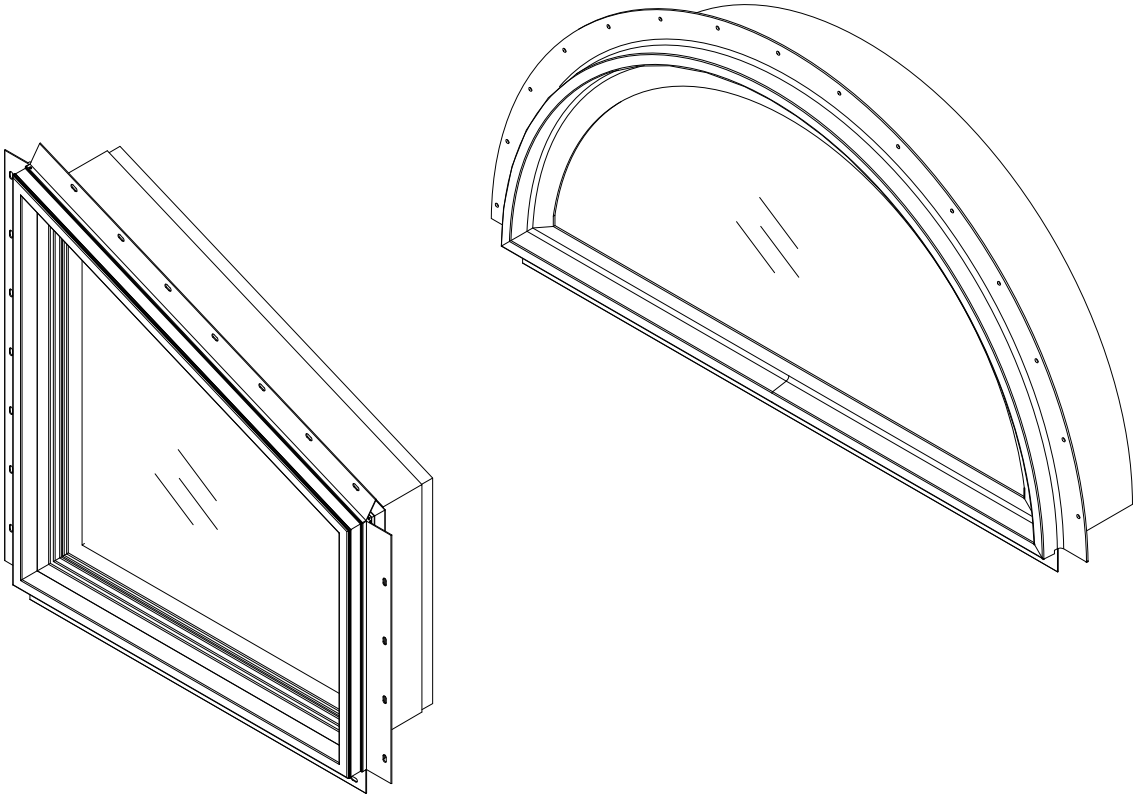

IMPORTANT: Read these instructions thoroughly before beginning to install your Essential Polygon or Round Top. Failure to install as recommended will void any warranty, written or implied. Regional applications and standards may vary, therefore Marvin Windows and Doors is not responsible for interpretations of local codes and/or ordinances. Installation of Marvin products is the sole responsibility of the installer, contractor, structural engineer, architect, building owner and/or consumer. After installation is completed, these instructions should be retained by the building owner. For additional information, consult your local Marvin dealer.

IMPORTANT: All windows and doors must have properly installed flashing systems and sealant at unit perimeter in accordance with accepted and proven construction methods.

WARNING! This product can expose you to chemicals including methanol, which is known to the state of California to cause cancer. For more information, go to www.P65Warnings.ca.gov

WARNING! This product can expose you to chemicals including titanium oxide, which is known to the state of California to cause cancer. For more information, go to www.P65Warnings.ca.gov

INDEX		Page
Part Identification		1
Installation Preparation		1
Rough Opening Preparation		2
Installing the Unit		2
Field Applied Jamb Extension Installation		4

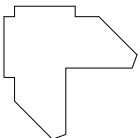
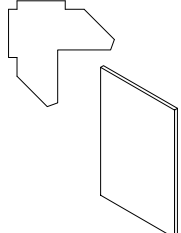
STANDARD PARTS SHIPPED WITH UNIT		
ILLUSTRATIONS (not to scale)	DESCRIPTION AND COLOR	PART/PROFILE NUMBER
	Nailing fin corner gaskets with instructions. Appropriate number supplied. For polygons and stand-alone round tops. Package of 4.	11869519
	Nailing fin corner gaskets and connector gaskets with instructions. For mulled round tops and polygons. Package of 4 (2 each)	11869509

YOU WILL NEED TO SUPPLY

- | | |
|---|-----------------------|
| Safety glasses | Hearing protection |
| Level | Square |
| Hammer | Shims |
| 2" Roofing nails | Fiberglass insulation |
| Tape measure | Utility knife |
| Interior trim or casing as desired | Seam seal tape |
| Self sealing adhesive flashing | |
| Drip cap flashing (for top of unit) | |
| Backing material (foam backing rod) | |
| Grade NS Class 25 sealant per ASTM C920— <i>sealant must be compatible with building exterior and window surface.</i> | |

NOTE: When specifying or considering the structural load requirements for windows and doors, it is important to consider the method of fastening the unit(s) into the opening. The methods contained herein may not be appropriate for all performance requirements. Selection of the appropriate fastening method is the sole responsibility of the installer, contractor, structural engineer, architect, building owner and/or consumer.

IMPORTANT: Non-abrasive household cleaners are recommended for regular cleaning and maintenance. Caution should be used with solvents and chemicals.

WARNING: Practice safety! Wear safety glasses or goggles and appropriate hearing protection when installing or performing adjustments to an Marvin product.

ATTENTION: Specifications and technical data are subject to change without notice.

NOTE: Numbers listed in parentheses () are metric equivalents in millimeters rounded to the nearest whole number.

INSTALLATION PREPARATION

NOTE: If you are field mulling components, be sure to do so before you begin the installation preparation. The specific procedures will be found with the appropriate field mullion kit.

1. Check rough opening (RO) size and configuration. When framing the rough opening, care should be taken to ensure sill plate is level and the opening is square. The rough opening height should be 1/2" (13) higher than the highest leg of the frame, the width should be 1" (25) wider than the widest part of the frame (1/2" on either side). The framing members should run in a perpendicular (90 degree) fashion to the frame and should allow for a 1/2" width dimension on each side (jamb) and head jamb if applicable. The masonry opening (MO) should allow for a 1/4" (6) width dimension between the frame cladding, or if applied, exterior casing and masonry opening. It is important to ensure that properly angled cross braces are applied around the perimeter of the rough opening to provide structural stability and an adequate nailing surface. See illustration 1.

IMPORTANT: It is essential that the sheathing behind the nailing fin be a solid wood surface to ensure the unit is secured to the wall.

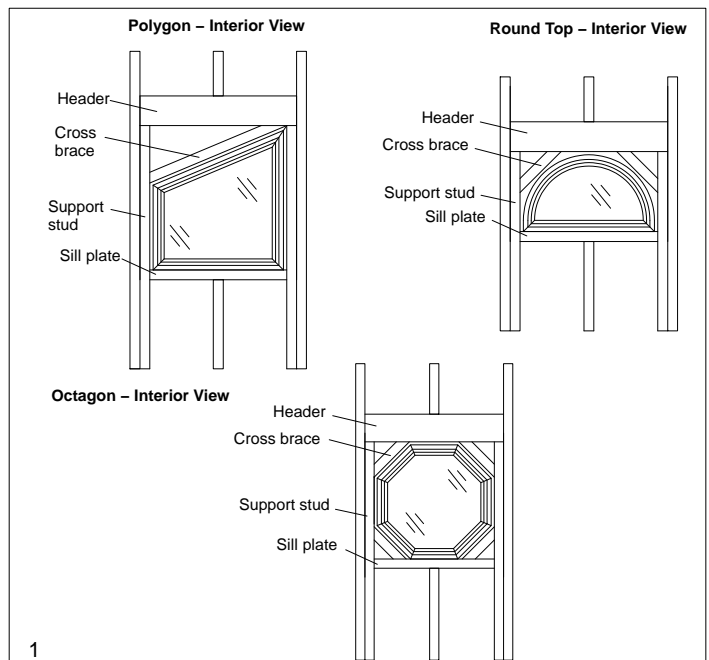

ROUGH OPENING PREPARATION

- If using building paper, skip to Step 4. If utilizing a continuous air barrier system on structure, it is recommended that windows are installed after application. When trimming away rough openings, cut as shown in examples in illustration 2. **DO NOT cut the air barrier in a diagonal fashion.**

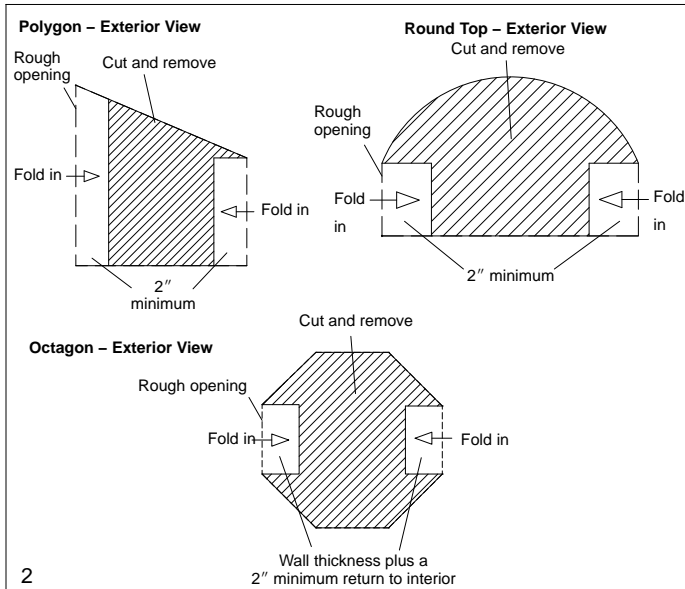

- Apply a piece of barrier which is approximately 12" (305) longer than the RO width, to bottom of opening across the entire width. Extend this piece at least 2" (51) to the interior and 4" (102) to exterior of opening. Tuck the excess 6" (152) on each side under the side flaps. Allow exterior section to lap over wall air barrier below. Wrap side pieces of barrier around opening to the interior, trim barrier to allow at least 2" to extend inside the structure, tack in place. Seal opening bottom corners between side and bottom barrier returns carefully with compatible seal tape. Cover all intersections with seam seal tape as well. Do not fasten to exterior at top of opening, this will allow nailing fin to be positioned under barrier during window installation. Apply sealant at sides and top of opening 1/2"–3/4" from edge. See illustration 3.

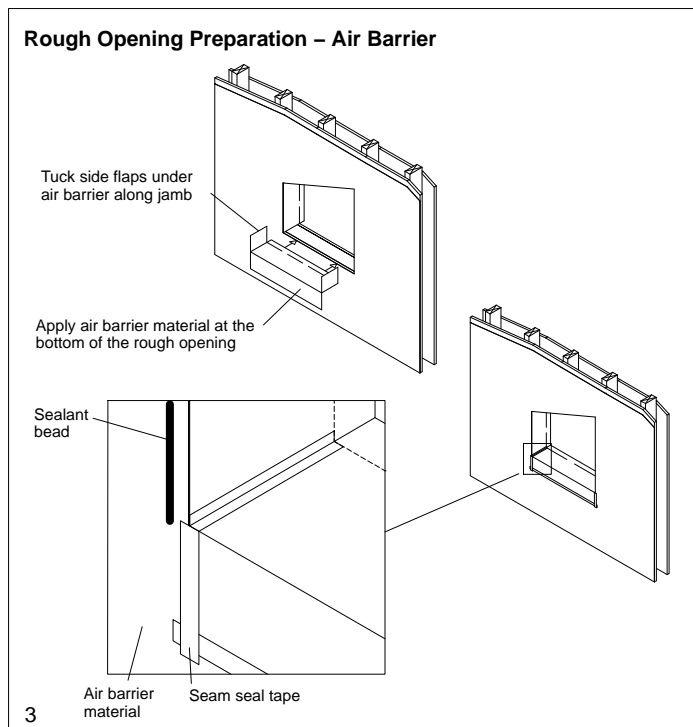

- If using building paper on structure, apply after windows are installed. However, prior to window installation, flash sides and bottom of opening with paper 2" (51) returns to the interior and 4"–6" (102–152) to exterior of opening. Seal bottom corners of flashing carefully with sealant, install unit. When applying paper to structure, use seal paper over head jamb nailing fin and side jamb nailing fin. At bottom, place paper under sill flashing before fastening nailing fin. See illustration 4.

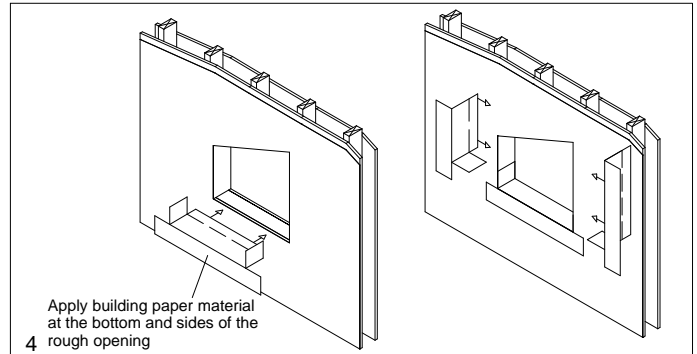

INSTALLING THE UNIT

- Remove any remaining protective packaging from unit and dispose/recycle properly. Inspect unit for any hidden damage and report immediately to your Marvin representative, provide unit order number and line number from label on exterior jamb or radius.
- Position the factory applied nailing fin in the upright position per instructions provided with product. **DO NOT APPLY ADHESIVE GASKETS AT THIS TIME.**
- On all units factory or field mullied, mullion joints must be sealed prior to installation. Apply silicone sealant at all mullions from the frame exterior edge to the drip cap/nailing fin kerf and across the kerf over the recessed mulling pin as shown in illustration 5. Apply nailing fin connectors at mullions by removing the paper backing from the connector and pressing into place.

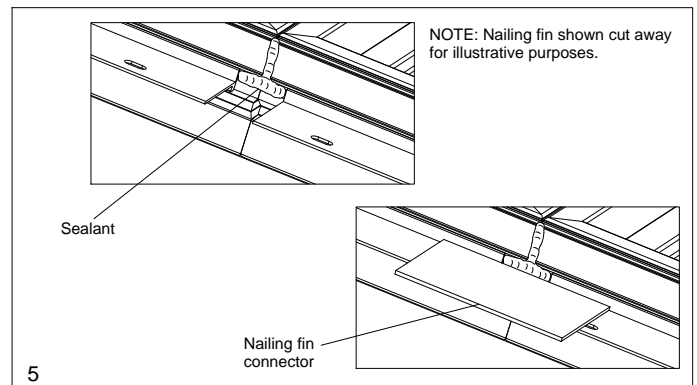

NOTE: If installing with structural masonry brackets or installation brackets refer to specific instructions for use at this time.

- Place unit into RO. Place head jamb nailing fin under air barrier/building paper. Cut air barrier/building paper at the corners (if applied before window installation). This will allow head flashing to lap over side flashing. Square frame if necessary. Be sure to plumb side jambs vertically (left/right and interior/exterior). See illustration 6. Apply shims between the jambs and the opening 4"–6" (102–152) from the edge of the corners. See illustration 7. Shims must be applied at cross brace locations.

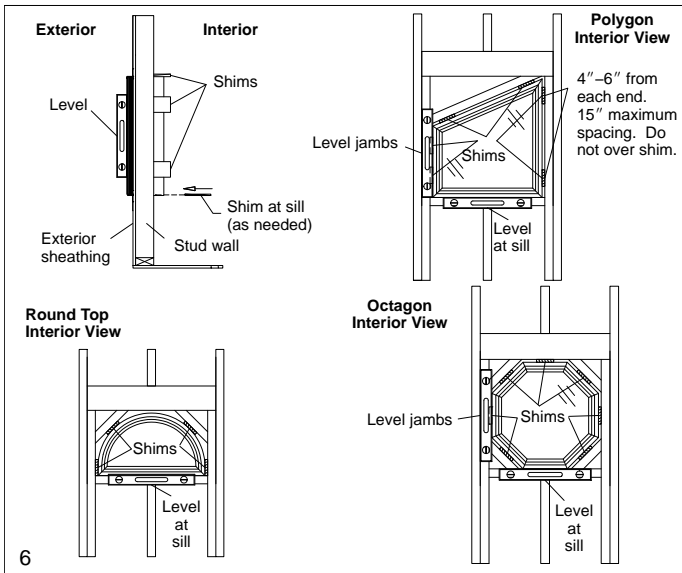

9. When window frame is square and plumb, nail through the upper corners of the nailing fin using 2" galvanized roofing nails. Do not drive the nails all the way in. This will be done after you are sure the window frame is square. If your unit is secured by installation brackets*, start at the interior upper corners and attach with #8 x 2" wood screws. See illustration 7.

* Specific installation instructions are supplied with product.

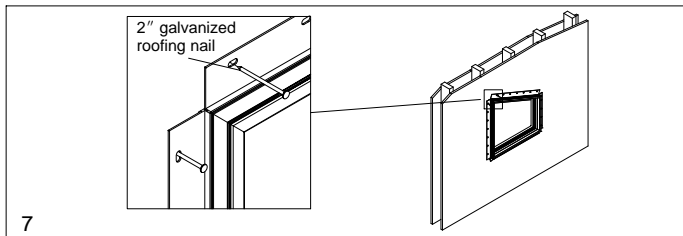

10. Recheck frame in relation to rough opening again. Add shims between those already installed, space 15" (381) apart (maximum) along radius or perimeter of frame. Adjust shims as necessary. See illustration 8. **DO NOT OVER SHIM.**

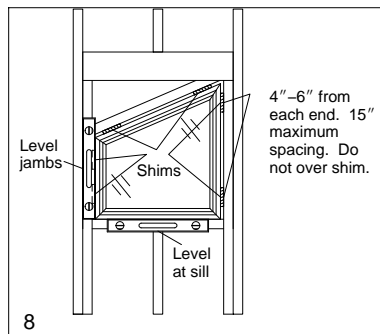

NOTE: Proper shimming is extremely important. Under shimming or over shimming will result in bowed jambs and/or head jamb. Both conditions can contribute to improper performance.

11. Complete nailing by securing bottom corners of the nailing fin at the sill with 2" galvanized roofing nails. Then nail every 6"–8" (152–203) around perimeter of frame. **Do not nail sill nailing fin until building paper has been applied to wall exterior.**
12. Apply silicone sealant into the Ultrex® nailing fin kerf wherever nailing fin joints occur on round tops or polygons. Fill the entire kerf between nailing fin and build up a 1/4" (6) bead along cladding. See illustration 9.
13. Apply nailing fin corner gaskets and connector gaskets to the appropriate locations of the nailing fin as described in this step. Muller round tops and polygons will require both corner gaskets and connector gaskets. It may be necessary to cut a small incision in the air barrier/building paper to allow easier application of the gaskets. Additionally, gaskets may require trimming in order to fit snug against non 90 degree angles. See illustration 9.

14. If applicable, position connector gasket over nailing fin joint and press in place. Corner gaskets are applied directly over the nailing fins. Apply additional sealant. See illustration 9.

IMPORTANT: The nailing fin is not designed to be a weatherproof flashing. When installing an Marvin product, the unit frame must be sealed to prevent water and air infiltration. When an air barrier system is used, apply seam seal tape from clad frame to barrier up sides and along top, do not apply at bottom.

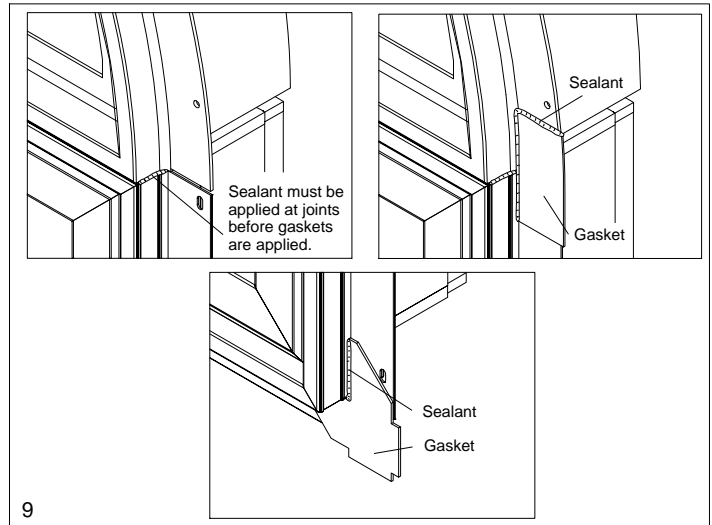

15. Install air barrier/building paper flashing around unit exterior perimeter sealed to the sheathing and frame of unit. Start at sill, up side jambs and across the head jamb or radius to ensure proper flashing overlap. See illustration 10.

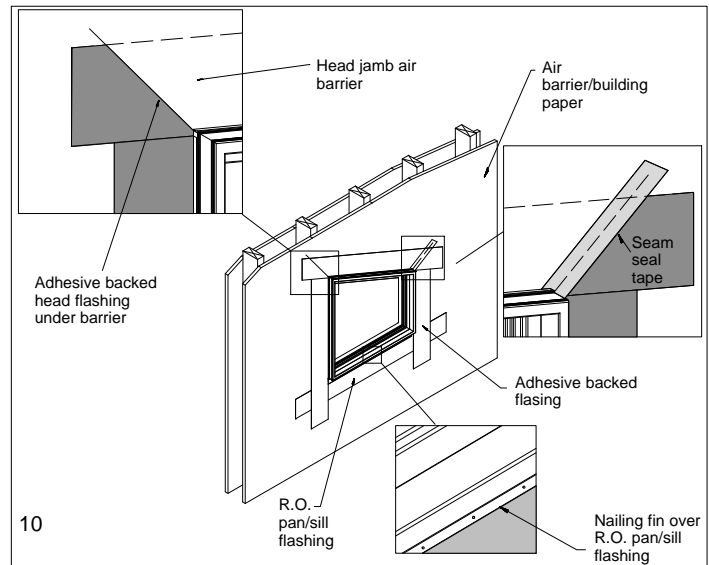

16. Cut off shims flush with the interior jamb to allow application of interior trim.
17. Fill the gaps between the window frame and framing members on interior with insulation. Do not pack tightly.

NOTE: Foam type insulation is required by some building codes. Use a low expansion type foam in combination with fiberglass insulation.

CAUTION: When using expanding foam insulation it is very important not to bow the head jamb and/or side jambs of the unit.

18. Install masonry or siding allowing a minimum 1/4" (6) gap between unit and exterior finish. Insert backing material (e.g. foam backing rod) between unit frame and structure to provide a proper sealant joint. Apply sealant around perimeter of unit frame along exterior. Sealant depth must be equal to width between unit and building exterior finish. Always refer to sealant manufacturer's recommendations for proper surface preparation and application procedures.

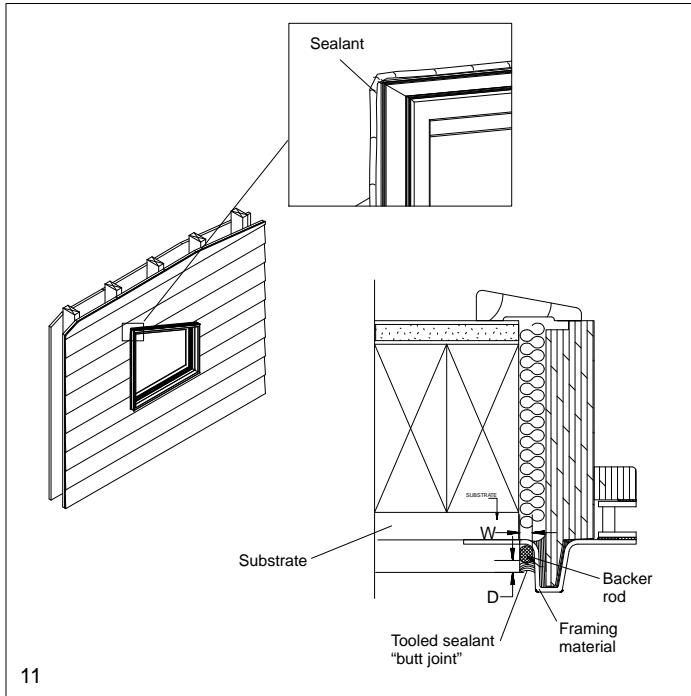

11

IMPORTANT: Perimeter sealant must be Grade NS, Class 25, per ASTM C920 and compatible with both the window/door product and the finished exterior(s) of the building or water and air infiltration resulting from sealant failure will occur.

FIELD APPLIED JAMB EXTENSION

(Polygon or Round Top / Quarter Round Stand Alone Units)

STANDARD PARTS SHIPPED		
ILLUSTRATIONS (not to scale)	DESCRIPTION AND COLOR	PART/PROFILE NUMBER
 W7432 shown	Jamb extension	See Parts and Service Manual for specific profile, length and part number.
	Jamb extension bracket (mulled round top units)	11040353
	#7 x 5/8" Phillips flat head wood screw (mulled round top units)	11800758

YOU WILL NEED TO SUPPLY

- Safety glasses
- Hammer
- #2 Phillips screwdriver
- Woodworkers glue (mulled round top units)
- 1/8 x 1 1/8" 18 gauge staples with gun or 4d finish nails
- Hearing protection
- Power drill

19. Field applied jamb extension are available in 6 9/16" or 6 13/16".
20. For 6 9/16" and 6 13/16" jamb extension, fasten to head jamb, sill or side jambs using 1/8" x 1 1/8" 18 gauge staples or 4d finishing nails spaced every 3" - 5" (76-127). Careful application of staples or nails is required to prevent damage to jamb extension and/or window unit. See illustration 12.

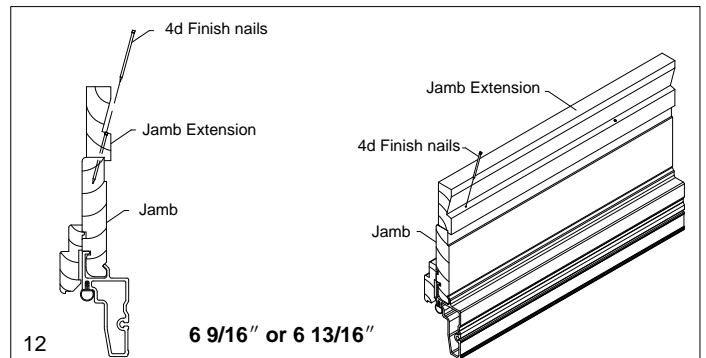

12

21. For 6 9/16" or 6 13/16" jamb extension, fasten corners of extensions using 1/8" x 1 1/8" 18 gauge staples or 4d nails as shown in illustration 13.

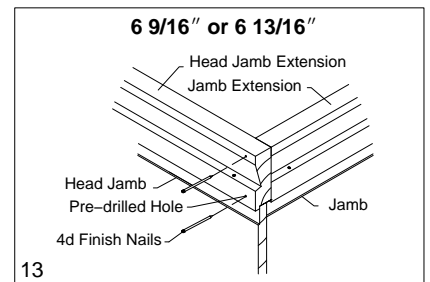

13

22. Follow installation instructions for installing unit into rough opening or masonry opening.

FIELD APPLIED JAMB EXTENSION MULLED ROUND TOP UNITS

23. Attach radius jamb extension to head jamb with 1/8" x 1 1/8" 18 gauge staples or 4d finishing nails spaced 3" - 5".
24. Using a #2 Phillips screwdriver or cordless screwdriver, attach the jamb extension bracket to the radius jamb extension on each side with two #7 x 5/8" Phillips wood screws. Apply a bead of woodworkers glue to the butt ends of the radius and lineal jamb extension. See illustration 14.
25. Join the radius and lineal jamb extension and adjust as necessary making sure the two members are aligned at the butt joint. Screw both jamb extension brackets to the lineal jamb extension with two #7 x 5/8" Phillips flat head wood screws. See illustration 14.

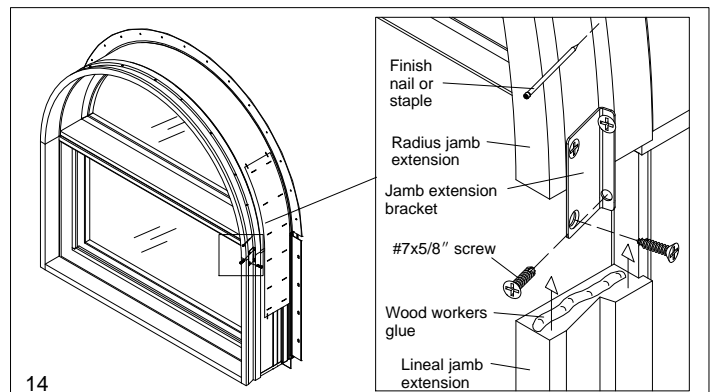

14

26. Nail the jamb extension to the jamb with 1/8" x 1 1/8" 18 gauge staples or 4d finishing nails spaced 3" - 5".
27. Follow installation instructions for installing unit into rough opening or masonry opening.