

# Elevate Casement or Awning Narrow Frame Installation Instructions

---

**ABSTRACT:** Specifications and technical data are subject to change without notice. These installation instructions demonstrate the installation of new Marvin windows in existing wood frame construction using an industry approved water management system. For other construction methods such as remodeling and recessed openings, refer to ASTM E2112-01. Standard Practice for Installation of Exterior Windows, Doors and Skylights for installation suggestions. Information on ASTM E2112-01 can be found on the ASTM website [www.astm.org](http://www.astm.org). For product specific issues, service instructions and other field service guides, refer to the Service Manual, visit our website at [www.marvin.com](http://www.marvin.com), or contact your Marvin representative. **Regional standard practices, environmental conditions, and codes may vary and supersede the procedures contained within. The responsibility for compliance is yours: the installer, inspector, and owner(s). Please read these instructions in their entirety before beginning to install your Marvin window product.** These instructions are for the following Elevate Narrow Frame window units:

Elevate Casement Narrow Frame (ELCANF)	Elevate Awning Narrow Frame (ELAWNF)	Elevate Casement Narrow Frame Picture (ELCANFP)
Elevate Casement Narrow Frame Transom (ELCANFTR)		

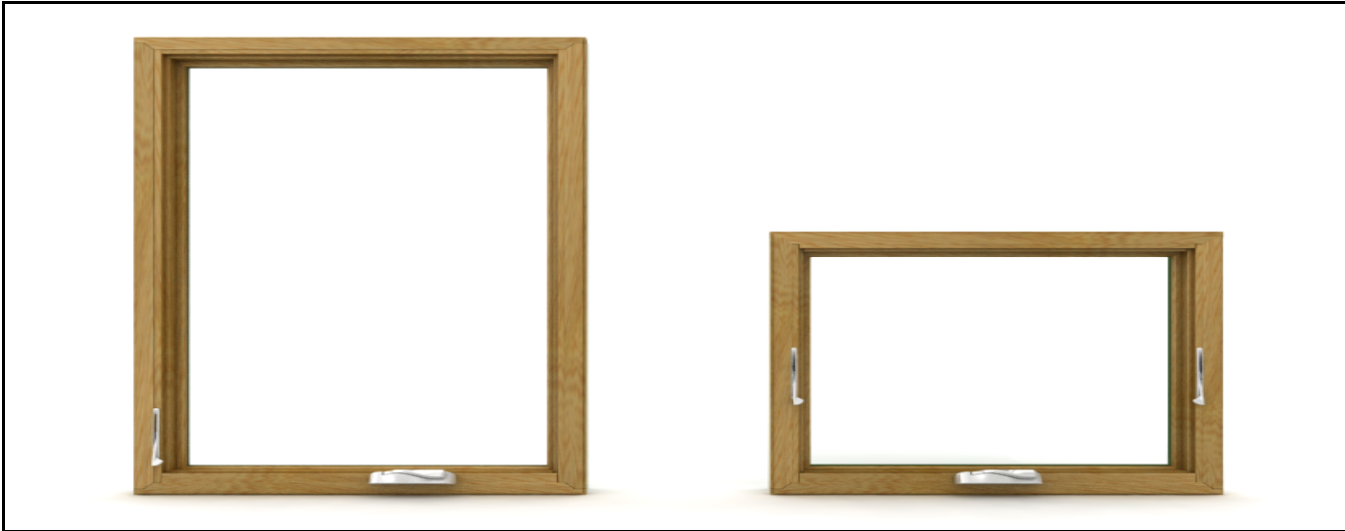

---

## Hazard Notations

### **WARNING!**

Always practice safety! Wear the appropriate eye, ear, and hand protection, especially when working with power tools.

### **WARNING!**

This product can expose you to chemicals including titanium oxide, which is known to the state of California to cause cancer. For more information, go to [www.P65Warnings.ca.gov](http://www.P65Warnings.ca.gov).

### **WARNING!**

This product can expose you to chemicals including methanol, which is known to the state of California to cause birth defects or other reproductive harm. For more information, go to [www.P65Warnings.ca.gov](http://www.P65Warnings.ca.gov).

### **WARNING!**

Drilling, sawing, sanding or machining wood products can expose you to wood dust, a substance known to the State of California to cause cancer. Avoid inhaling wood dust or use a dust mask or other safeguards for personal protection. For more information go to [www.P65Warnings.ca.gov/wood](http://www.P65Warnings.ca.gov/wood).

### **WARNING!**

Older homes may contain lead-based paint, which may be disturbed when replacing windows or performing renovations. Consult state or local authorities for safe handling, disposal, or abatement requirements. For information, go to [www.epa.gov/lead](http://www.epa.gov/lead).

---

## Before You Begin

These instructions detail how to prep an existing frame for a new Marvin window. Installation into other window frames may require adapting the window opening preparation process. Consult with your Marvin representative concerning installation into other window frame openings.

*NOTE: Numbers listed in parentheses () are metric equivalents in millimeters rounded to the nearest whole number.*

---

## ***After Market Products***

Alterations to Marvin products including window films, insulating or reflective interior window treatments or additional glazings can cause excessive heat buildup and/or condensation. They may lead to premature failures not covered under warranty by Marvin Windows and Doors.

Before purchasing or applying any product that may affect the installation or performance of Marvin windows or doors, contact the manufacturer of after-market product/glazings that are not supplied by Marvin and request written product use, associated warranties and damage coverage. Provide this information and warranties to the end user and/or building owner for future reference.

---

## ***Installer and Builder Information***

- Always provide a copy of these instructions for the current homeowner.
- Plan sizing of rough opening and clearance from exterior finishing systems to allow for normal materials shrinkage or shifting (e.g. wood structure with brick veneer; allow adequate clearance at the sill). Failure to do so can void the Marvin warranty coverage.
- Refer to the Technical Installation Specifications section for technical specifications regarding the installation of this product. These installation requirements as well as the details in the section must be followed to achieve the advertised design pressure (DP) rating of this product.
- It is the responsibility of the builder, installer, and subcontractors to protect the interior and exterior of windows or doors from contact with harsh chemical washes, construction material contamination and moisture. Damage to glazing, hardware, weather strip and cladding/wood can occur. Protect with painters tape and/or protective sheathing as required. Follow all guidelines regarding material use, preparation, personal safety and disposal.
- Refer to the enclosed painting and staining instructions for exterior and interior finish instructions.
- Contact your Marvin supplier if you have any questions regarding product and materials used in manufacturing or questions on replacement parts.
- Please refer to the PDF version of this instruction for further information regarding best practices installer and builder information, code, and other legal requirements. The PDF version is the official document of record.

---

## You Will Need to Supply

- Safety glasses
- Hearing protection
- Level
- Square
- Hammer
- Shims
- Fiberglass insulation
- Tape measure
- Perimeter sealant
- Chisel
- Utility knife
- Foam backer rod
- Pry bar
- Adjustable pliers
- Putty knife
- Reciprocating saw
- Power drill with bits
- Frame expander
- Foam type insulation if required/accepted by local code
- Sealant

*NOTE: Sealants used for installation must be Grade NS Class 25 per ASTM C920 and compatible with the building exterior, window exterior surface, and flashing/water management materials.*

---

## Prepare the Unit

*NOTE: Inspect unit for color, damage, and size prior to installation.*

1. Remove and properly discard all shipping material.
2. Remove all screens and loose hardware, set aside for future use.

### IMPORTANT

When preparing unit for installation, the covers and stops need to be removed before installing.

3. Insert a through jamb screw into one of the two head jamb mounting holes. Tap gently with a hammer to create a small opening to insert a putty knife. See [Figure 1](#).



Figure 1

4. Carefully pry the head jamb stop away from the frame with a putty knife. Follow the same procedure to remove the stationary jamb stop and lastly the operator jamb stop. See [Figure 2](#).



**Figure 2**

After the head jamb and stationary/operator jamb stops are removed, pull the hardware cover with both hands to remove.

**After** the unit is installed, replace both jamb stops first, followed by the head jamb stop and then the sill hardware cover.

Ensure operating units are in the closed and locked position until secured in the opening and ready for final adjustments. Once the unit has been shimmed and secured in the opening, open the unit and remove any shipping blocks placed between the frame and sash. Operate the sash and perform final adjustments to the frame to ensure smooth operation of the unit.

## ***Exterior Installation-Prepare the Opening in Existing Construction***

### **IMPORTANT**

Before beginning installation be sure to inspect the existing opening for any signs of rot, decay, or other deterioration. It is essential that all substrates and sheathing be solid and free from defects to ensure proper installation. If the above conditions are not met, please take corrective action and repair and/or replace components as necessary.

1. On exterior applications, use a reciprocating saw or hammer and chisel to remove the blind stop. Cut it flush with the exterior casing and frame. [See Figure 3.](#)

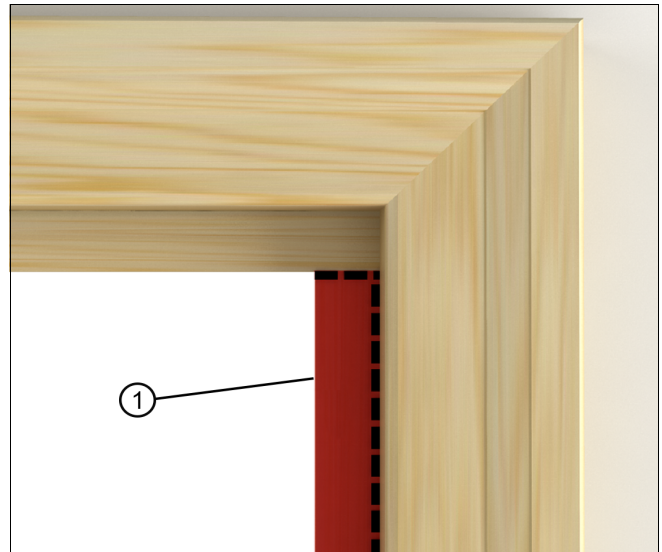

**Figure 3**

1	Remove this portion of the jamb blind stop
---	--

2. If the existing window unit used a weight pocket and pulley system, lower the top sash and cut the balance cords to remove the sash. Disconnect and remove any balance mechanisms attached to existing window frame.

3. Remove the head jamb and side jamb parting stops with a pry bar or adjustable pliers. [See Figure 4.](#)

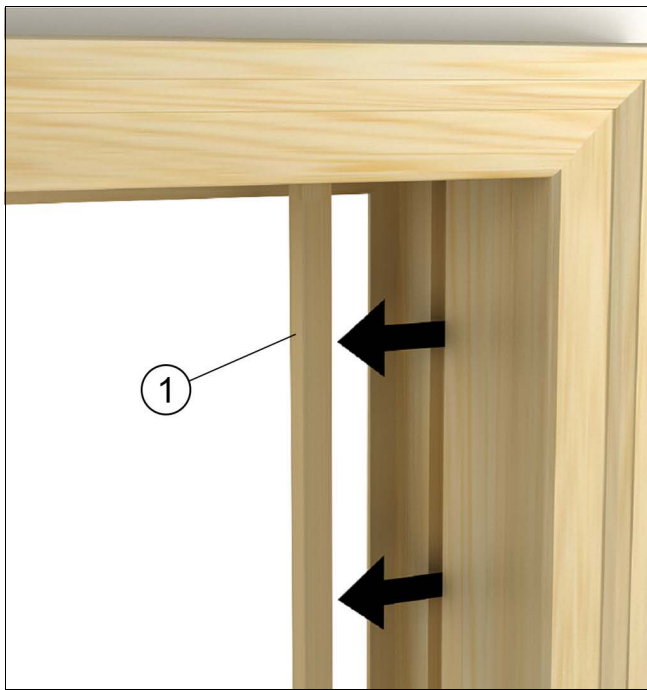

Figure 4

1	Remove this portion of the head jamb parting stop
---	---

4. If applicable, cut the balance cords on the lower sash and remove them from frame. Remove any remaining balance mechanism hardware from the existing frame that may hinder installation. If your frame used weight pockets at the jambs, remove them (if possible) and fill cavity with insulation.

5. Remove any debris or dirt in the opening. Apply a 1/4" (6) bead of sealant at both sill to jamb joints and on the back of the interior sash stops or moulding. See [Figure 5](#).

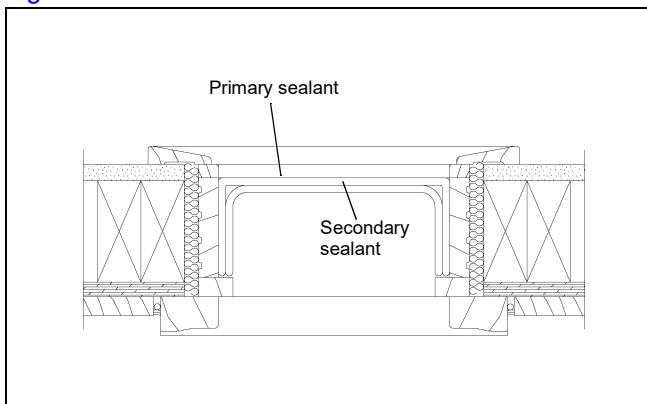

Figure 5

6. Apply a secondary continuous bead of sealant on sill as shown in [Figure 6](#). The placement of the secondary continuous bead of sealant is the same on interior and exterior installation.

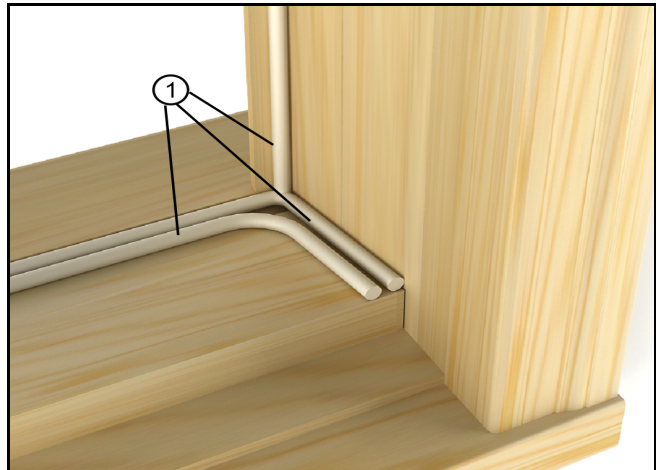

Figure 6

1	1/4" beads of sealant
---	-----------------------

## Interior Installation-Prepare the Opening in Existing Construction

### IMPORTANT

Before beginning installation be sure to inspect the existing opening for any signs of rot, decay, or other deterioration. It is essential that all substrates and sheathing be solid and free from defects to ensure proper installation. If the above conditions are not met, please take corrective action and repair and/or replace components as necessary.

1. Remove all interior stops with a pry bar or stiff putty knife. It may be necessary to break the paint seal with a utility knife.

### IMPORTANT

Do not break or damage interior stops if they are to be reused.

2. Remove the lower sash from the frame. If the existing window unit used a weight pocket and pulley system, raised the lower sash, cut the balance cords, and then remove the sash.

3. Remove the parting stop from head jamb with a stiff putty knife or pry bar. [See Figure 7.](#)

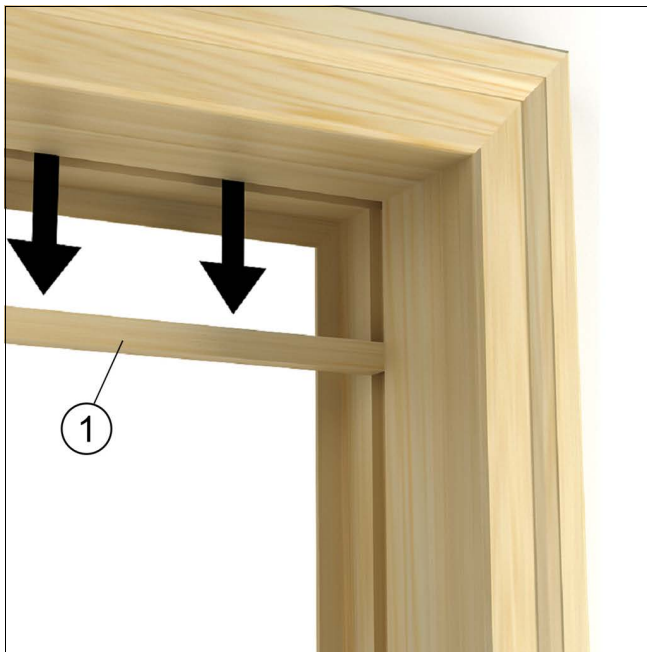

Figure 7

1	Remove this portion of the head jamb parting stop
---	---

4. Remove parting stops from both side jambs. [See Figure 9.](#) Lower the top sash and cut the balance cords. Remove the top sash, disconnect and remove any balance mechanisms attached.

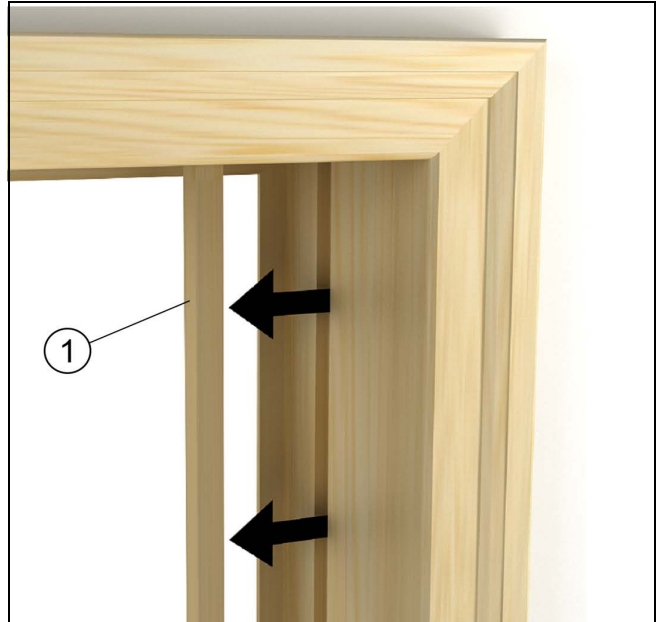

Figure 8

1	Remove the parting stops from side jamb
---	---

5. Remove the head jamb and side jamb parting stops with a pry bar or adjustable pliers. [See Figure 9.](#)

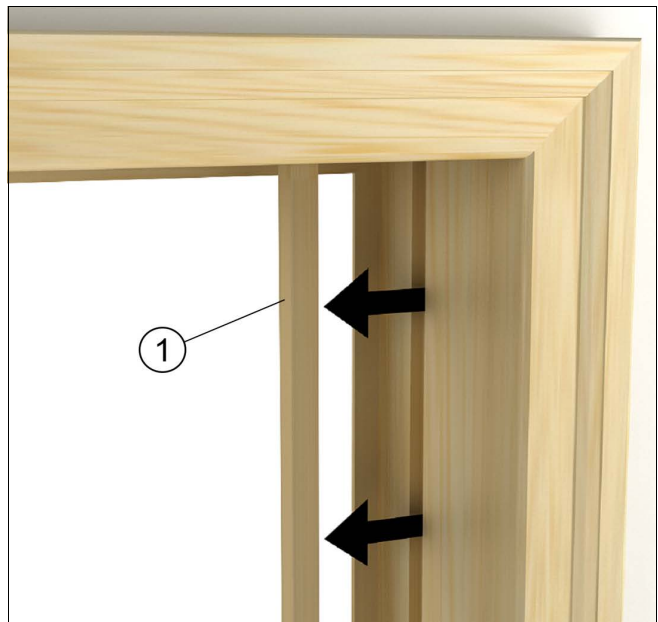

Figure 9

1	Remove this portion of the head jamb parting stop
---	---

6. Remove any remaining balance mechanism hardware from the existing frame such as balance cords, balance cord pulleys, etc. If your frame used weight pockets at the jambs, remove the weights (if possible) and fill cavity with fiberglass insulation.

7. Remove any debris or dirt in the opening. Apply a 1/4" (6) bead of sealant at sill to jamb joints, sill to sill liner/stool joints, and on the back of the blind stop of existing window frame. See Figure 10.

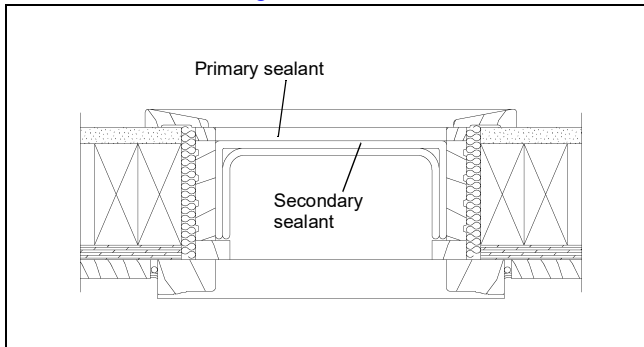
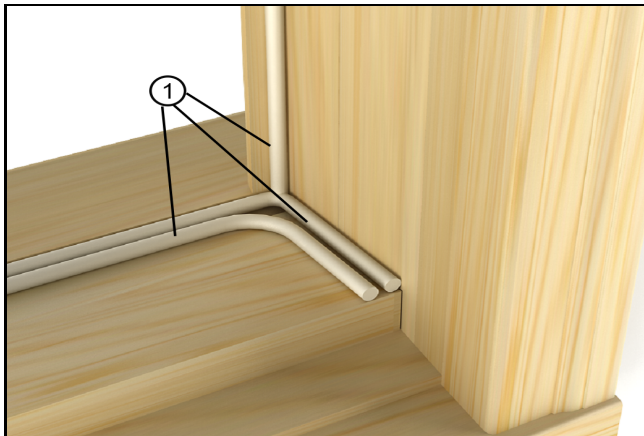

Figure 10

8. Apply a secondary continuous bead of sealant on sill as shown in Figure 11. The placement of the secondary continuous bead of sealant is the same on interior and exterior installation.





## Installing the Window-Nailing Fin Method on New Construction



### Seek Assistance

Some large windows and/or assemblies are very heavy. Avoid injury by getting help to lift and position the window into the rough opening.

**NOTE:** Prepare unit and follow Rough Opening Preparations in the [RO PREP Instruction](#).

**NOTE:** Images in this section are for illustrative purposes only, your window may look different.

1. Center the window in the opening. Level at the sill and plumb the frame (interior/exterior). Shim under the jambs to bring to level if necessary. See [Figure 11](#).



Figure 11

2. Once level, tack the jamb nailing fin with 2" (51) roofing nails within in 4" (102) from the head jamb. See [Figure 12](#).



Figure 12

### ! CAUTION!

Proper shimming is extremely important. Under-shimming or over-shimming will result in bowed jambs and or head jamb. Both conditions can contribute to improper window operation

3. From the interior, shim about 4" (102) from the bottom to square the unit in the opening. Take diagonal measurements of the window. When equal, the window is square in the opening. Adjust the shims until the unit is square in the opening. [Figure 13](#).



Figure 13

4. Once square, fasten the lower corners of the nailing fin and recheck for square. See [Figure 14](#).



Figure 14

## ATTENTION

For units installed with masonry clips or installation brackets. Bend bracket around framing member and attach with the #8 x 1 5/8" screws. Angle screws approximately 15° away from the window. Always shim above or below brackets. See [Figure 15](#).

*NOTE: Depending on construction method or wall type, you may need to modify the clip/bracket to fit the opening. Fastening holes should be no more than 1/4" from the bend in the bracket. If necessary, drill two 5/32" (3) holes in the bracket.*



Figure 15

5. Recheck the diagonals one more time to make sure the unit is square in the opening. If square, install additional shims at 15" intervals on center. Always shim at check rails and meeting stiles. See [Figure 16](#).



Figure 16

6. Measure at head jamb, center of unit, and sill to make sure all dimensions are equal. If they are not, you will have to adjust the shims accordingly. See [Figure 17](#).



Figure 17

7. Once the unit is square and plumb in the opening, operate the sash (on operable units) to make sure it is operating properly. If not, you may have to make some adjustments to the shims.

## Tip

On operating units, one way to make sure that the unit is installed square is to check the reveal (gap) between the operating sash and the frame. An even reveal around the entire sash generally means a squarely installed unit and will ensure smooth operation.

8. Complete fastening of the nailing fin around the perimeter of the unit with 2" (51) roofing nails 4" (102) from each corner and spaced every 6"- 8" (152-203) on center (or fasten remaining structural brackets.)

### IMPORTANT

Ensure that the unit has been installed square in the opening.

## Installing the Narrow Frame Window- Existing Construction

9. Center the unit in the opening. Depending on interior or exterior installation, press unit against interior sash stop or blind stop. See Figure 18.



Figure 18

### IMPORTANT

Do not to over or under shim the jambs.

10. If necessary, place shims under corners of unit to level. Level the unit horizontally from jamb to jamb at the sill of the unit.



Figure 19

11. Place shims at the bottom corners at the pre-drilled screw holes in the jamb. See Figure 20. (Horseshoe type stackable shims recommended.)

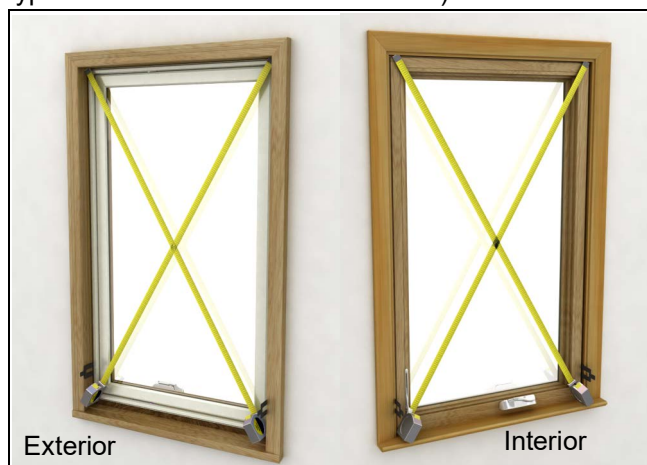

Figure 20

12. After panel alignment is corrected, recheck latch and deadbolt operation.

*NOTE: ELCANF mullied units have a shipping bracket applied across the mull. If the brackets impede installation into the opening, remove bracket(s) and install unit.*

13. Drive the #8 x 3" (76) screws into pre-drilled screw holes at the bottom corners. Only tighten until snug. See Figure 18.

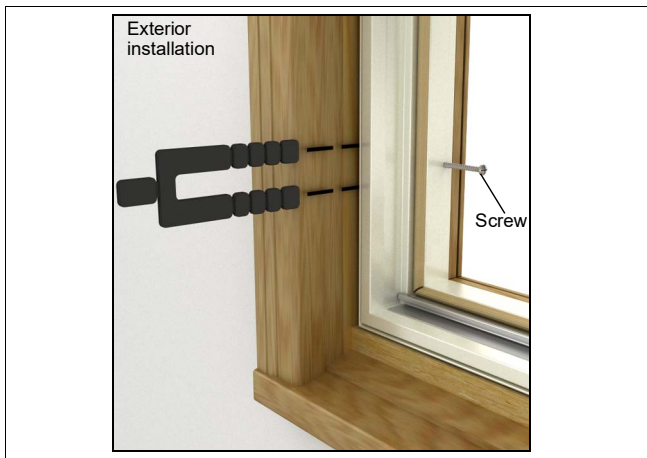

Figure 21

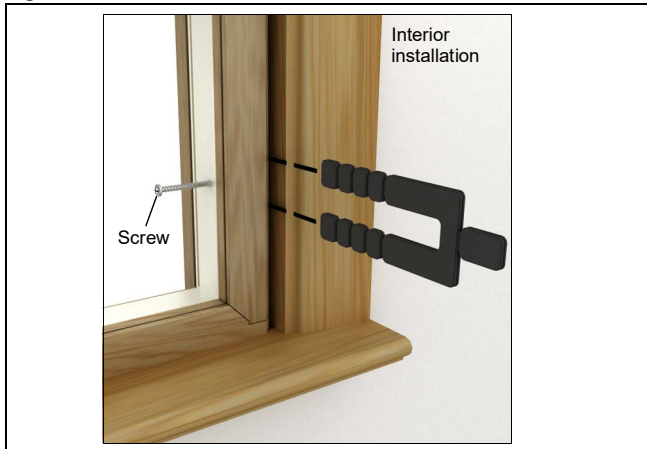

Figure 22

14. On installations with a sloped existing sill, install a wedge shaped block underneath sill at both corners, in the center of the unit, at all meeting stiles and mull locations to provide adequate support. Blocking material to be held back 3/4" (19) from exterior of unit to allow for proper installation of frame expander.

Place shims at the bottom corners at the pre-drilled screw holes in the jamb. See Figure 23. (Horseshoe type stackable shims recommended.)

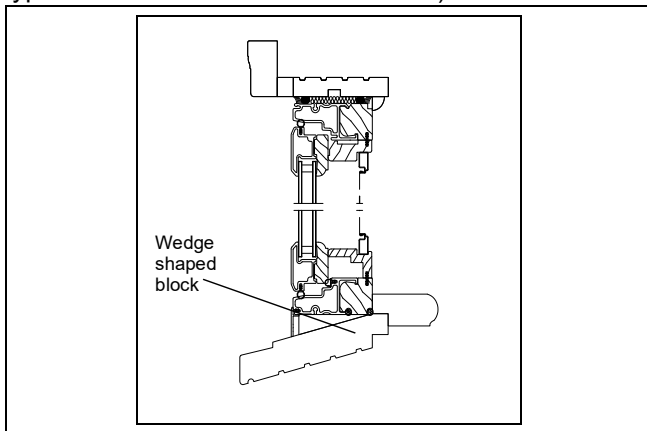

Figure 23

15. Square frame by taking diagonal measurements. Measurements should be equal. Adjust frame by applying shims at pre-drilled screw holes in jambs. Adjust upper shims as necessary. See Figure 24.



Figure 24

16. Square frame by taking diagonal measurements. Measurements should be equal. Adjust frame by applying shims at pre-drilled screw holes in jambs. Adjust upper shims as necessary. See Figure 24.

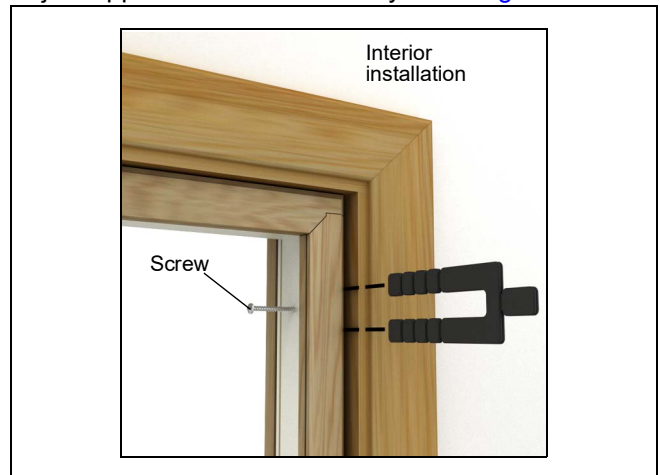

Figure 25

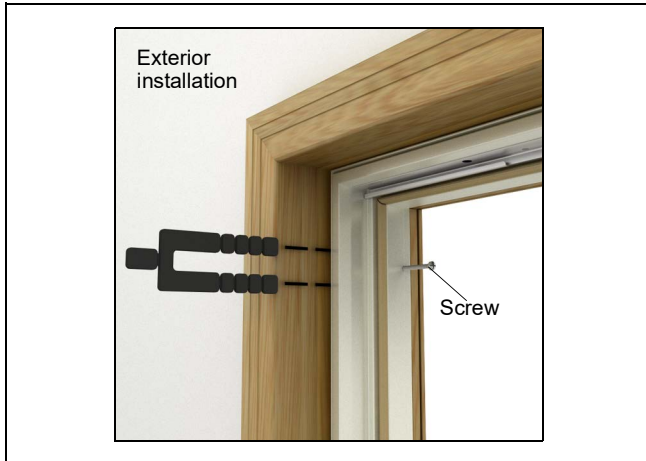

Figure 26

17. Recheck diagonals for squareness. Adjust screws as necessary to obtain frame squareness. If square, apply additional shims between the side jambs and existing window opening at additional pre-drilled holes.

18. Fasten unit in the opening through additional installation holes. Be sure to shim these additional through jamb holes.

19. Once the unit is flush, square, and plumb in the opening and sash operate properly, cut shims flush with the interior jamb or exterior of frame.

## Sealing the Opening

1. Fill gaps between the new window frame and existing window frame with fiberglass insulation. Do not pack tightly.

*NOTE: Foam type insulation may be used to form an infiltration seal as required by some building codes. However, a low expansion and low compression type foam should be used in combination with fiberglass insulation.*

### ! CAUTION!

When using expanding foam insulation it is important not to bow the head jamb or side jambs of the replacement unit.

2. For interior installation, run a bead of sealant between the new frame and existing frame around the entire interior perimeter. If necessary install backer rod prior to sealant application. Replace interior sash stops or new trim as desired.

### ! CAUTION!

If accessory kerf is unused, add sealant into miter of accessory kerf.

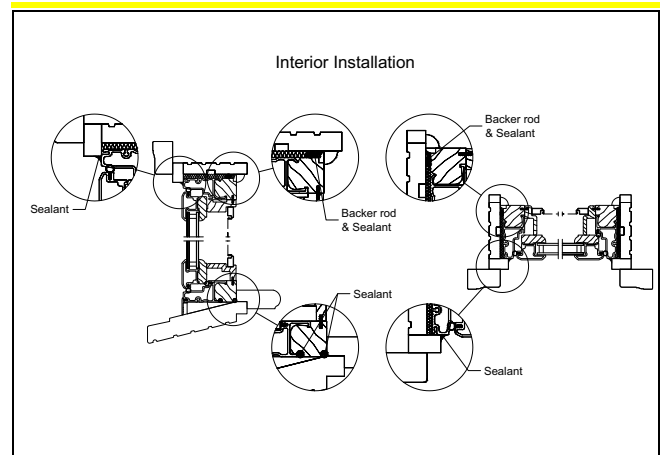

Figure 27

3. For exterior installation, apply a backer rod between the new frame and existing window frame. Place a bead of sealant over the backer rod, so that it contacts both the new frame and existing window frame.

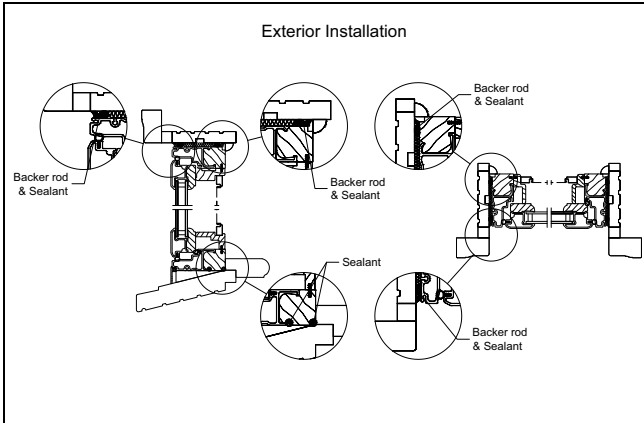

Figure 28

4. For both installation types, trim out the sill with frame expander.

5. At the exterior, run a bead of sealant between the new window and the existing window frame (blind stop on interior applications).

6. Finish the cut edge of the blind stop on exterior installations with paint, stain, or other type of sealer.

---

## Final Installation Procedure

Elevate Casement Narrow Frame units are supplied with two shipping blocks on each non-hinged corner that must be removed after installation has been completed. Unlock sash and open to remove shipping blocks. Install hardware cover, jamb stops, and head jamb stop.



Figure 29