

Ultimate Outswing Door G2 KD

Installation Instruction

ABSTRACT: This instruction will show how to install a KD *(knock down) Outswing Door. This is relevant for product produced from June 2021 to present and applies to the following products:

- Ultimate Outswing G2 (UOFD G2)
- Ultimate Outswing 2 1/4" G2 (UOFD2.25 G2)
- Ultimate Outswing Door (UOD)
- Ultimate Outswing Door 2 1/4 IZ3 (UOD2.25 IZ3)
- Ultimate Outswing French Door 2 1/4 IZ3 (UOFD2.25 IZ3)

WARNING!

Do NOT lift or move without proper equipment.

Read, understand, and follow all lift equipment manufacturers' instructions and safety information.

WARNING!

Drilling, sawing, sanding or machining wood products can expose you to wood dust, a substance known to the State of California to cause cancer. Avoid inhaling wood dust or use a dust mask or other safeguards for personal protection. For more information go to www.P65Warnings.ca.gov/wood.

WARNING!

This product can expose you to chemicals including titanium oxide, which is known to the state of California to cause cancer. For more information, go to www.P65Warnings.ca.gov.

WARNING!

This product can expose you to chemicals including methanol, which is known to the state of California to cause birth defects or other reproductive harm. For more information, go to www.P65Warnings.ca.gov.

WARNING!

Always practice safety! Wear the appropriate eye, ear, and hand protection, especially when working with power tools.

Sill to Jamb Assembly

1. Align jamb sub assembly into sill key until fully seated. Once seated, use #8 x 1-1/2" pan head screw through the sill key into the jamb cladding. See Figure 1

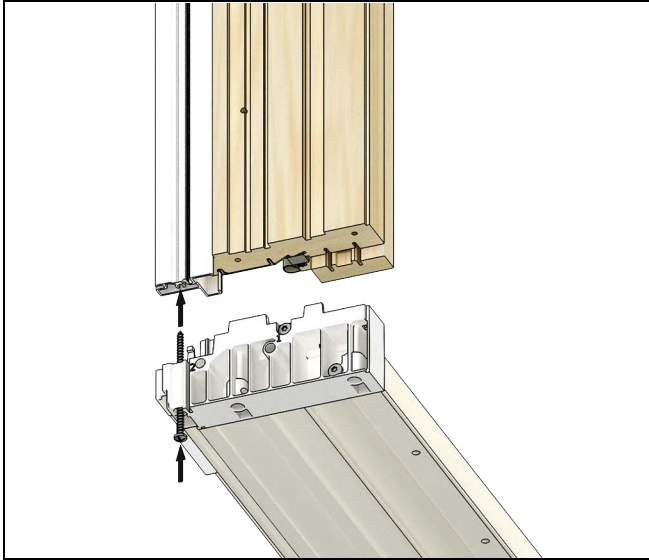

Figure 1

2. Use two #8 x 3" pan head screws to screw through the sill key into jamb wood. See Figure 2.

NOTE: You may need a longer Philips bit to fully seat these screws. If a shorter bit is used, the screw may not fully seat and the screw could strip out.

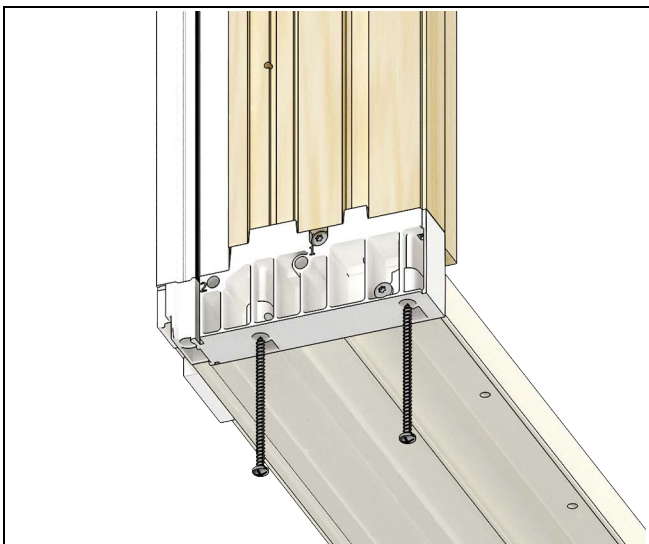

Figure 2

3. Repeat for opposing jamb.

ATTENTION

Take care when assembling the jamb to the sill to not roll or cut the sill gasket. See Figure 3.

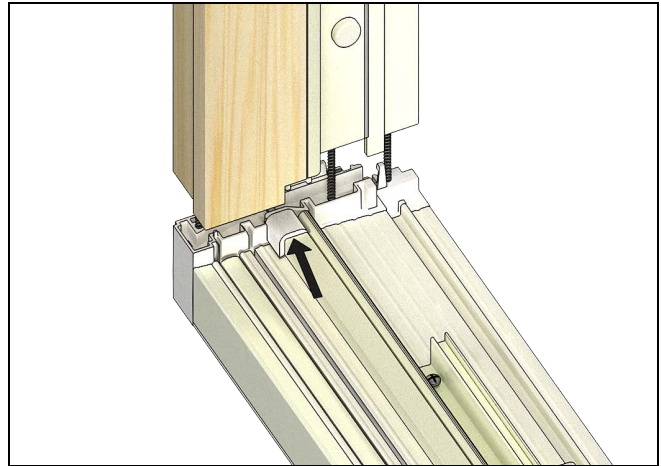

Figure 3

Head Jamb to Jamb Assembly

1. Align both head jamb keys into the hollows of the jamb clad until fully seated. [See Figure 4.](#)



Figure 4

2. Use #7 x 2" screw through the outer-most hole of the head jamb cladding into the screw boss of the jamb cladding (the interior holes on each side are used for injection). [See Figure 5.](#)



Figure 5

3. Use two #7 x 2" screws to screw through the pre-drilled holes located on the side of the jamb wood into the header wood. Make sure you are pushing the head jamb wood down towards the jamb wood to fully seat it prior to screwing. [See Figure 6.](#)



Figure 6

ATTENTION

Take care when assembling the jamb to the head jamb to not roll, or cut the sill gasket or crush the weather strip. [See Figure 7.](#)



Figure 7

Injecting the Unit

1. Locate the injection hole on the side of the sill key labeled "2". Inject into the key until you see squeeze out in the inspection hole shown below. [See Figure 8.](#)



Figure 8

2. Use the remaining holes in the head jamb cladding to inject the keys. Inject until you see squeeze out in the image shown below. [See Figure 9.](#)



Figure 9

Panel Installation- Installing Stationary Panel

You will need to evaluate your panel configuration to determine which panel will be installed first into the newly assembled frame.

Stationary panels first, passive panels next and finally active panels.

1. If the stationary panel is attached to a jamb of the frame, insert the panel into the frame by lining up the groove in the bottom of the panel onto the structural brackets that are screwed down onto the sill. See [Figure 10](#) and [Figure 11](#).



Figure 10



Figure 11

2. Slide the panel over to the jamb until it contacts the spacer tacks. See [Figure 12](#).



Figure 12

3. Push panel in until it compresses the interior stop weather strip. See [Figure 13](#).

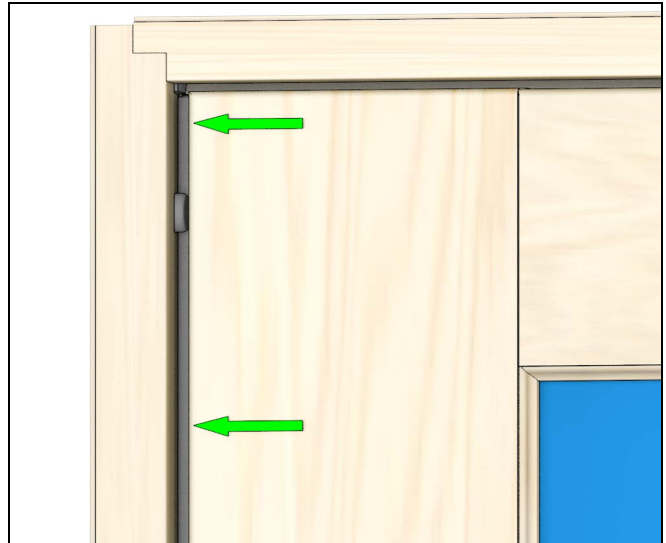

Figure 13

4. Insert the stationary bolt by inserting the top of the bolt into the hole located in the head jamb of the frame. Push the bottom of the bolt until it is flush with the side of the panel. Use two #8 X 3" screws to secure the stationary bolt to the panel. See Figure 15.



Figure 14



Figure 15

5. Align and install stationary panel bracket with two #8 x 3" screws. See Figure 16.



Figure 16

6. If the stationary panel is not against a jamb of the frame, there will be four stationary bolts that will be installed. See Figure 17.



Figure 17

7. Locate pre-drilled installation holes on the exterior of the jamb. Use #8 X 3" screws to fasten the stationary panel through the jamb. See Figure 18.

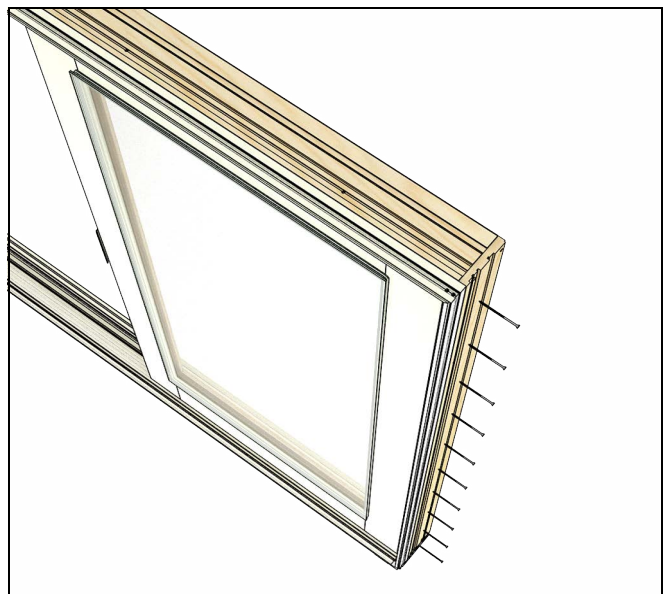

Figure 18

Panel Installation-Installing Operating Panel (Jamb Hinged)

You will need to evaluate your panel configuration to determine which panel will be installed first into the newly assembled frame.

Stationary panels first, passive panels next and finally active panels.

1. Insert jamb hinges into routs located on the panel. Use #8 X 1-1/2" screws to secure the hinge to the panel. See [Figure 19](#). Repeat for all hinges.

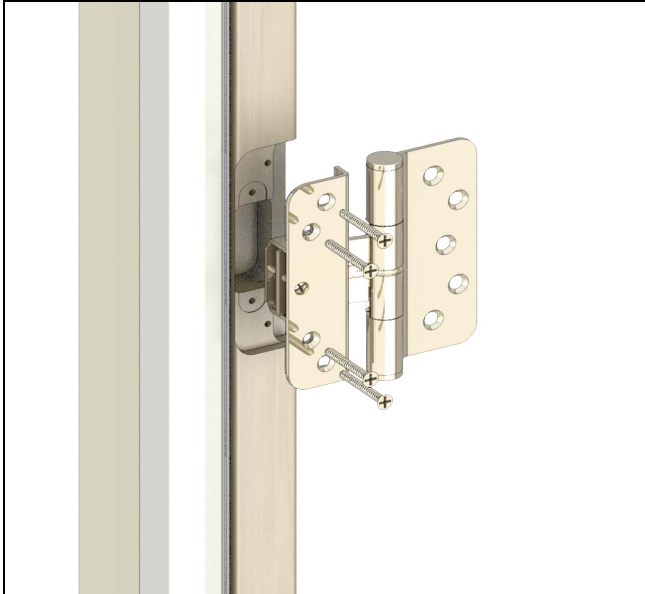

Figure 19

2. Close panel to ensure proper alignment with frame. See [Figure 20](#).

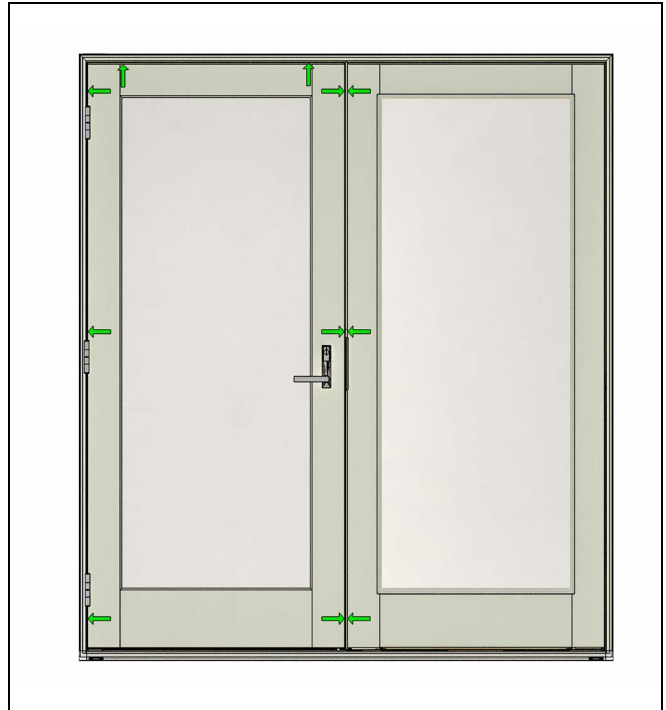

Figure 20

3. Fully lock your panel for installation. See [Figure 21](#).



Figure 21

Panel Installation-Installing Operating Panel (Panel Hinged)

You will need to evaluate your panel configuration to determine which panel will be installed first into the newly assembled frame.

Stationary panels first, passive panels next and finally active panels.

1. Insert hinges into routs on stationary panel. Use #8 X 1-1/2" screws to secure the hinge to the panel. See [Figure 22](#). Repeat for all hinges.

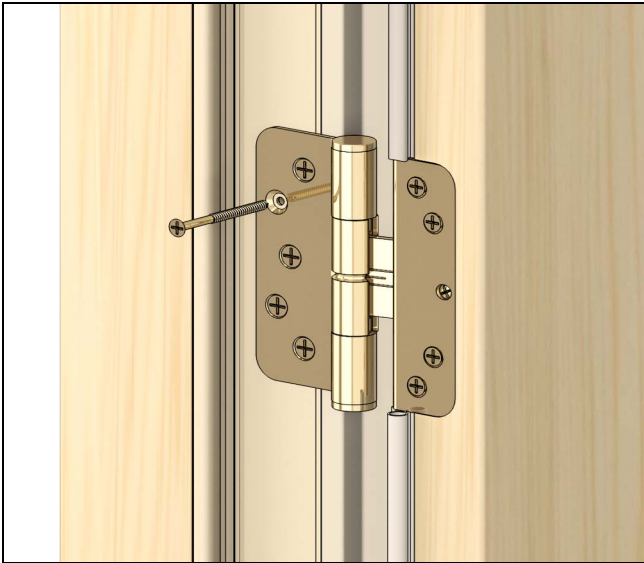

Figure 22

2. Close panel to ensure proper alignment with frame. See [Figure 23](#).

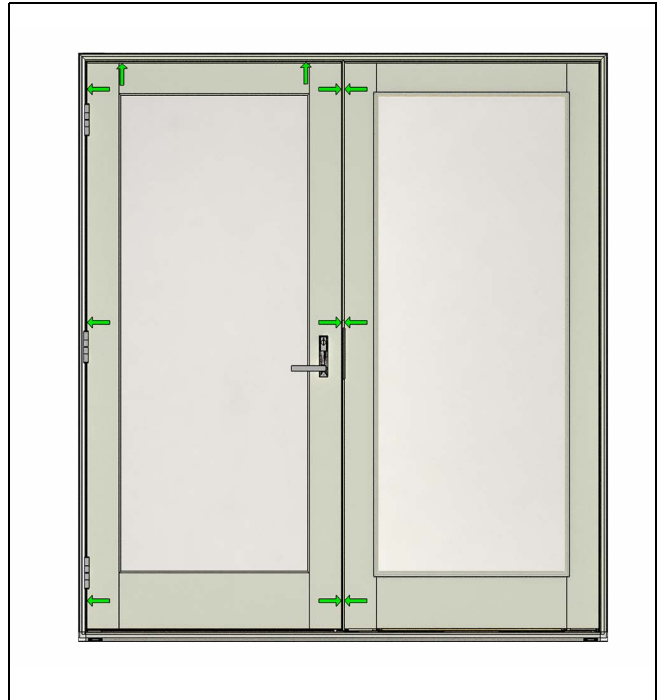

Figure 23

3. Fully lock your panel for installation. See [Figure 24](#).



Figure 24