

Essential Through Jamb

Supplemental Installation Instructions

ABSTRACT: The following instructions are intended to be used in conjunction with the supplied installation instructions for proper installation techniques including opening preparation, flashing and sealing details. Always read these and all instructions in their entirety before installing your Essential product.

You Will Need to Supply

- Power drill
- Rubber mallet
- Stiff putty knife
- 3/16" Drill bit
- Caulking gun
- Tape measure
- Phillips head screw driver
- Construction adhesive (APA rated AFG-01 spec.)

Attach Installation Brackets

NOTE: Casement Awning units do not use jamb or head jamb brackets. Skip to step 3 for mullled units or step 1 on page 3 for non-mullled units.

1. Install a bracket at every installation hole in the jamb and head jamb. See [Figure 1](#).



Figure 1

NOTE: You may need to remove or move sash to access installation holes.

2. Fasten brackets to frame with #7 x 5/8" screws. See [Figure 2](#).

NOTE: You may use one of the 3" installation screws inserted through the bracket to keep it aligned with the installation hole.



Figure 2

3. On vertically mullled units with 1/2" space mull, remove the interior mull cap. See [Figure 3](#).



Figure 3 Mullioned units with 1/2" Space Mull

4. For 1/2" Space Mullioned Assemblies: Place a mull bracket at the sill end of the aluminum mull tie as shown in [Figure 4](#) and attach with #7 x 5/8" flat head screws.

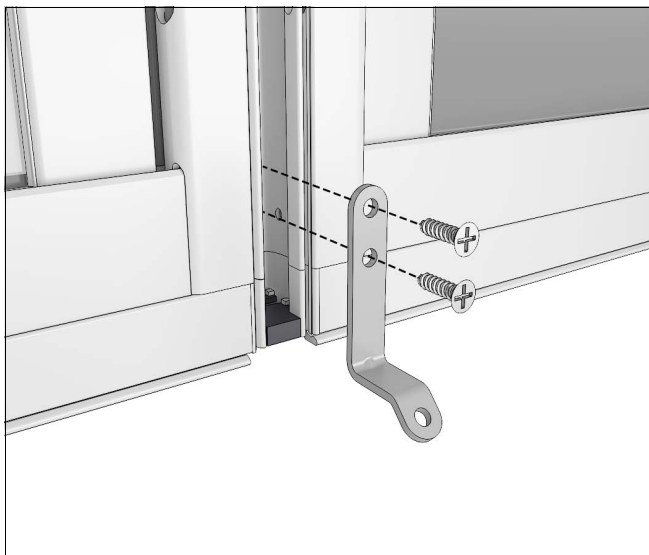

Figure 4 Mullioned units with 1/2" Space Mull

5. For 1/2" MRF Assemblies: For factory mulls, remove existing shipping screw in the reinforcement before installing the brackets. Install jamb and head jamb brackets. Apply 90-degree bent structural brackets within 1-1/8" (29) of either side of the mull with 5/8" screws on both ends. Install a third 90-degree bent structural bracket into the mull end with 2" screws on both ends. Apply a third bracket between the first two centered on the mull. Follow the instructions sent with the brackets. See [Figure 5](#).

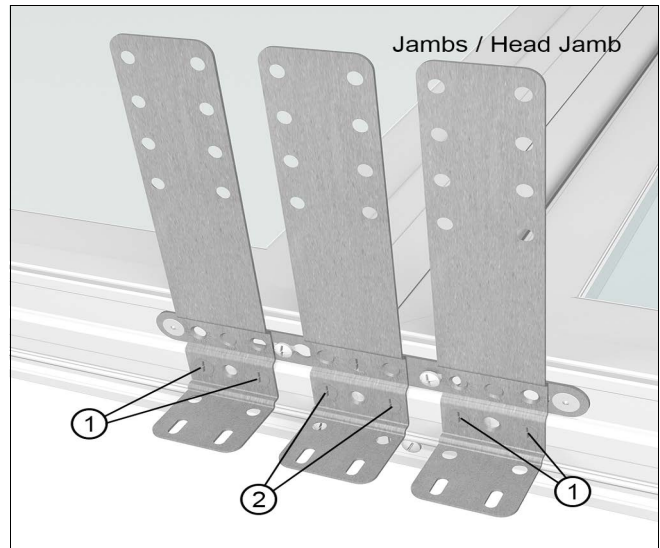

Figure 5 Jamb/Head Jamb bracket placement

6. For 1/2" MRF Assemblies: Install Sill brackets. Apply two "flat" sill structural brackets within 1 1/8" of either side of the mull. Apply one 90 degree bent structural bracket between the first two, centered on the mull. See [Figure 6](#).

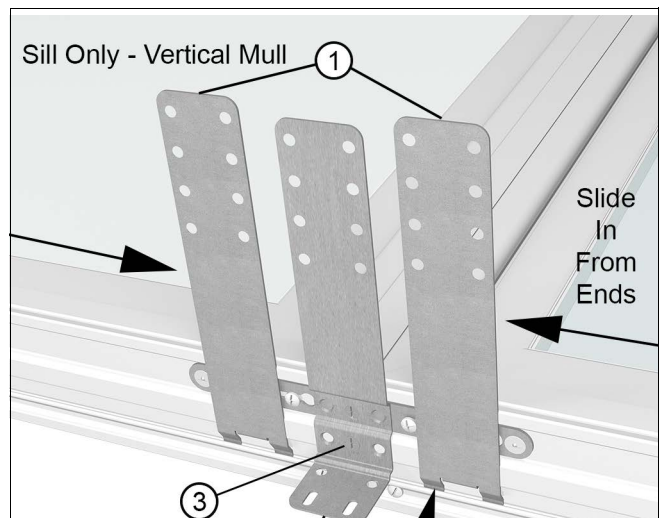

Figure 6 Sill bracket placement

1	Flat sill structural bracket
2	90-degree bent structural bracket

7. If you are installing a window with structural brackets apply a 3/16" (5) diameter 1 1/2" (38) long bead of heavy duty construction adhesive in the exterior jamb channel. The adhesive is to be placed 6" (152) in from each corner and spaced 12" (305) apart along the head jamb and jambs of the unit. Press the 90-degree bent structural brackets firmly into place over the adhesive and secure with the two provided screws in the structural bracket kit. See [Figure 7](#), [Figure 8](#) and [Figure 9](#).

IMPORTANT

Do not apply 90-degree bent brackets on sill.

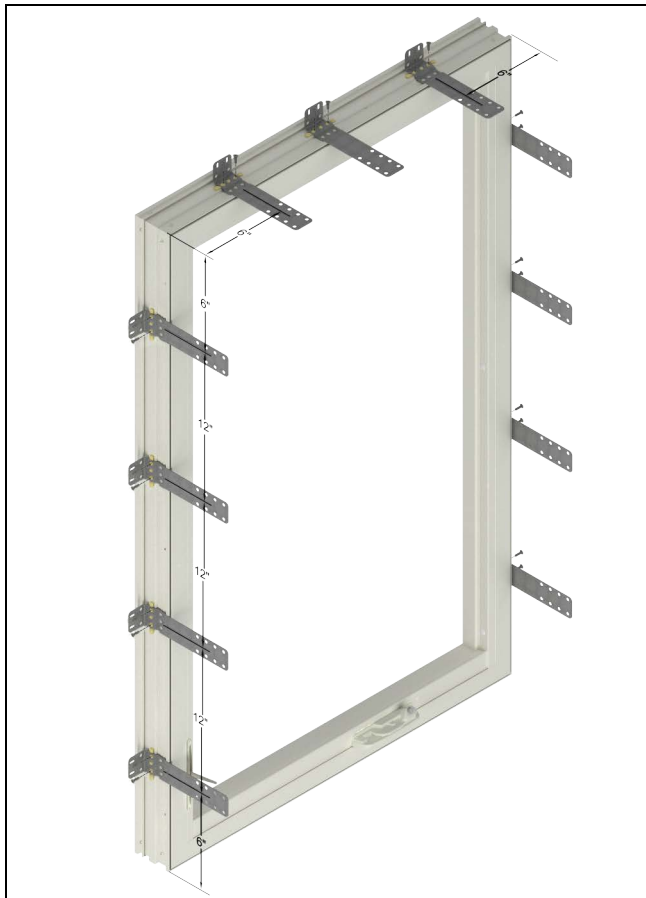

Figure 7

NOTE: Screw placement is different for Direct Glaze versus all other product. The bracket is fastened to the Direct Glaze using the holes closer to the interior (markings on the bracket denote proper screw placement). See [Figure 8](#) and [Figure 9](#).

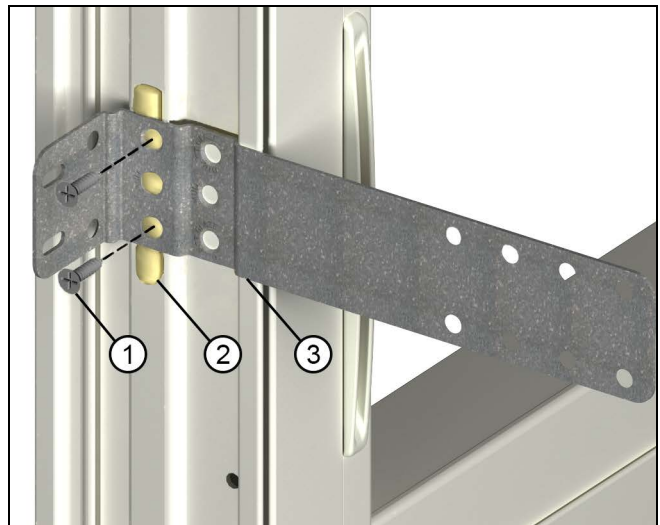

Figure 8 All product except Direct Glaze

1	Screw
2	Sealant
3	90-degree bent structural bracket

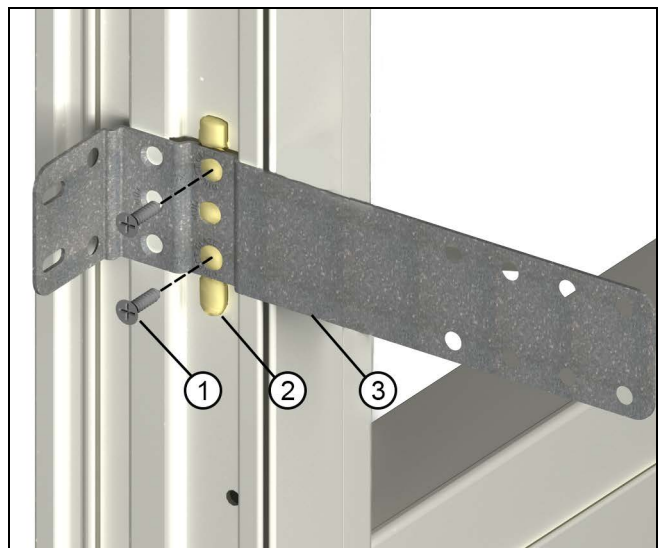

Figure 9 Direct Glaze

1	Screw (using holes closest to interior)
2	Sealant
3	90-degree bent structural bracket

8. Slide flat sill structural brackets into T-slot channel at the sill. Insert enough brackets to ensure a bracket is within 6" of each corner and evenly spaced 12" apart along the sill. Final adjustment of bracket locations should be done once the unit is resting in the opening. See [Figure 10](#).

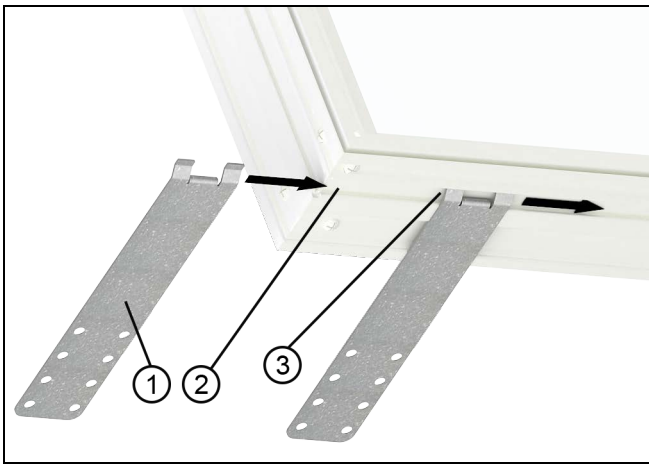

Figure 10

1	Sill structural bracket
2	Slide
3	T-slot

9. On masonry openings you will need to modify the bracket. Remove the front leg of the bracket by cutting with a metal cutter or similar tool. See [Figure 11](#).

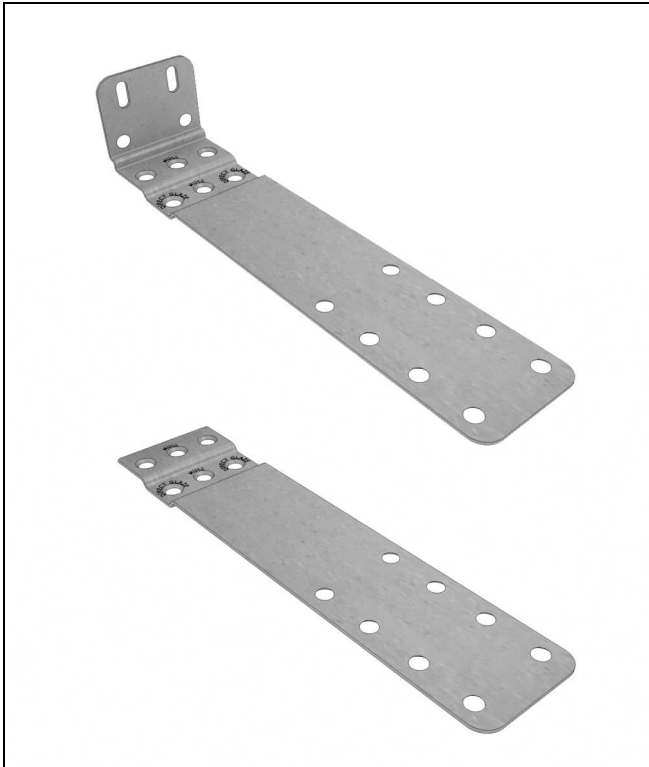

Figure 11

1	Remove front leg for masonry opening application
2	Bracket after modification

Units with interior accessories (does not apply to ESCA units): The barb used to fasten accessories to the frame will interfere with the installation screw. Use a 3/16" drill bit to bore out the hole and remove barb material from the area. See [Figure 12](#).



Figure 12

10. On field mullered ESDHP/T units: Remove the head jamb stop with a stiff putty knife. Slide the brackets 4" (102) from the corners of the mulls and use the center hole on the bracket as a guide to drill 3/16" holes in the frame. Fasten to frame with #7 x 5/8" screws. See [Figure 13](#).



Figure 13

Preparing the Opening and Installing the Window

1. On units with a frame width of 41 1/2" (1054) or more, place three 3/8" (10) beads of construction adhesive on the sill so that the window will contact these beads in all three locations See [Figure 14](#). Place construction adhesive below the sill on all Casement/Awning and Round Top products.

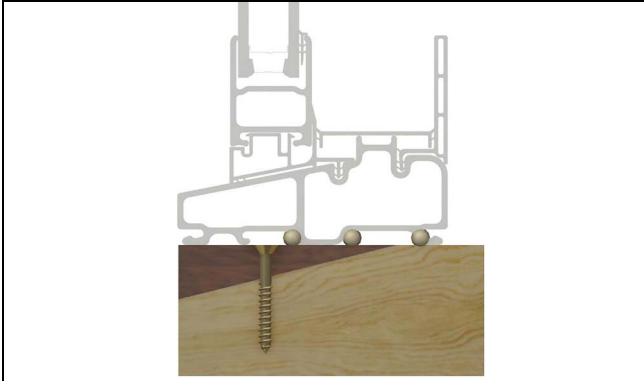

Figure 14

2. Square and plumb the unit in the opening (refer to installation instructions). Place shims above every installation hole. Apply the #8 x 3" screws to permanently secure the unit to the framing members. Cover with hole plug. See [Figure 15](#).

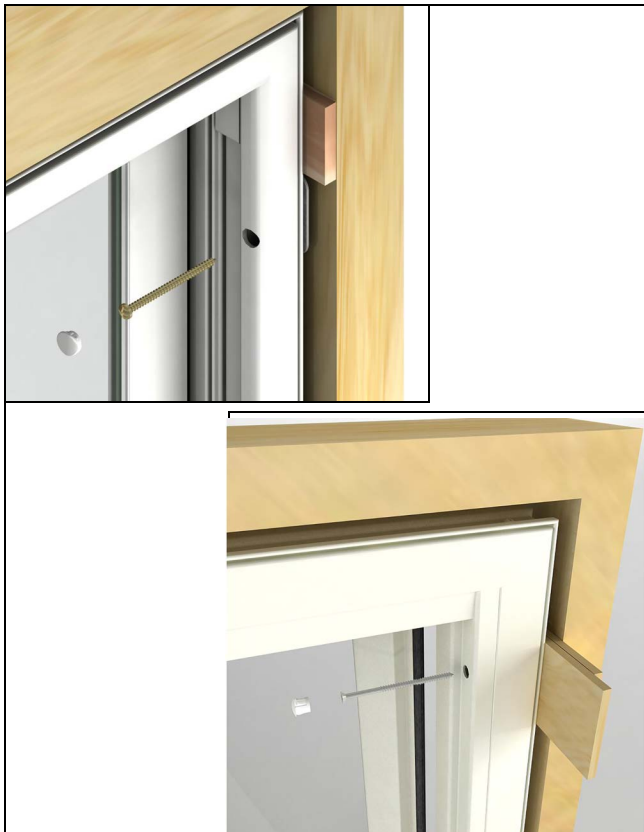

Figure 15

3. Vertically Mullered Units with 1/2" Space Mull: Pre-drill through mull bracket and into rough opening with a 3/16" drill bit and fasten with installation screw. Replace the mull cap removed earlier. See [Figure 16](#).



Figure 16

ATTENTION

For units installed with masonry clips or structural brackets. Bend bracket around framing member and attach with the #8 x 1 1/4" screws. Angle screws approximately 15° away from the window. Always shim above or below brackets. See [Figure 17](#).



Figure 17 Attaching window with structural brackets.

Figure 18 Other items available for installation:

- Essential Window Installation Instructions
19970123
- Field Applied Through Jamb Position Kit (includes instruction) for ESSH/DH/GL/ESRT-11800042
- Through Jamb Installation Kit for ESSH/DH/GL/ESRT-11800040. For ESCA/AWN and ESSWP/T-11800043
- Through Jamb 1/2" Space Mull Installation Kit for ESSH/DH/GL/IFRT, ESCA/AWN, and ESSWP/T-11800039