



# Ultimate and Ultimate Wood Commercial Door

## Replacement Parts

Specifications and technical data are subject to change without notice.

Numbers listed in ( ) parentheses are metric equivalents in millimeters rounded to the nearest whole number.

Suggested fasteners are not included and must be ordered separately.

Illustrations are not to scale.

## Contents

Product History.....	2
Part ID - Ultimate Wood Commercial Door - XX RHRA.....	3
Part ID - Ultimate Wood Commercial Door - Stationary/Sidelite.....	4
Part ID - Ultimate Wood Commercial Door - Direct Glaze Rectangle .....	5
Part ID - Ultimate Wood Commercial Door - In-Sash Transom.....	6
Part ID - Ultimate Wood Commercial Door 2 1/4 Inch - XX RHRA.....	7
Part ID - Ultimate Wood Commercial Door 2 1/4 Inch - Stationary .....	8
Part ID - Ultimate Commercial Door - XX RHRA.....	9
Part ID - Ultimate Commercial Door - Stationary and Sidelite .....	10
Part ID - Ultimate Commercial Door - Direct Glaze Rectangle .....	11
Part ID - Ultimate Commercial Door - In-Sash Transom .....	12
Part ID - Ultimate Commercial Door 2 1/4 Inch - XX RHRA .....	13
Part ID - Ultimate Commercial Door 2 1/4 Inch - Stationary .....	14
Hinges.....	15
Miscellaneous Parts .....	16
Miscellaneous Parts - Discontinued - Limited Availability.....	20
Miscellaneous Parts - Discontinued - No Availability.....	21
Vinyl Parts.....	23
Wood Parts.....	24
Wood Parts - Discontinued - Limited Availability - DISC-LA .....	26
Wood Parts - Discontinued - No Availability - DISC-NA.....	27
Weather Strip .....	28
Weather Strip - Fabricated .....	30
Weather Strip - Discontinued - Limited Availability .....	31
Door Hardware - Configured Parts in OMS.....	32
Replacement Sills - Configured Parts in OMS.....	34
Panel Replacement - Configured Parts in OMS .....	35
Panel Replacement - Light Commercial Door Prep 2000-2005.....	36

Produced	Unit Type	Features and Changes
2000	Wood and Clad Light Commercial Prep Door Introduced	01/17/2000: Unit uses common parts with outswing door. Jambs square cut at bottom to accept commercial or ADA sills. Ball bearing 4" butt hinges standard. 11 3/8" bottom rail standard. 8/4/2000: Brushed chrome ball bearing hinges available.
2005	Ultimate and Ultimate Wood Commercial Door	Commercial Door is introduced, Outswing Light Commercial Door retired. New Commercial Door features 6" stile, 11 3/8" bottom rail, and 4 1/2" ball bearing hinges.
2006	Ultimate and Ultimate Wood Commercial Door 2 1/4inch	02/2006: Commercial Door 2 1/4inch is introduced.
2007	All Commercial Doors	02/20/2007: Introduced raised and flat panels as a standard option.
2009	Ultimate and Ultimate Wood Commercial Door 2 1/4inch	03/30/2009: Implemented design changes to the 2 1/4inch. Changes include new panel seep, dust blocks, IZ3/IZ4 wood bead and shoot bolt reinforcement.
2011	All Commercial Doors	04/25/2011: White painted interior option introduced for all products.
2012	All Commercial Doors	07/30/2012: Hardware rout options and hardware functions. New panel drip added. 10/29/2012: Interior Square Sticking/Glazing Bead option introduced. 12/17/2012: Introduced Clear Interior Finish option on all products.
2013	All Commercial Doors	04/29/2013: Introduced interior stain options. Stain colors are Wheat, Honey, Leather, Hazelnut, Cabernet and Espresso.
	Ultimate and Ultimate Wood Commercial Door Direct Glaze Transom	06/24/2013: Direct Glaze Standardization added upgrades and improvements to direct glaze products in both wood and clad. Glazing method is silicone and interior tape glazed. Wood bead profile is W11751.
2014	All Commercial Doors	08/25/2014: Panel drip (A2408) will now match clad color. Screws will match standard clad colors. For Custom Color Clad, screws will be stainless steel. See Product Bulletin 566 for more information.
2016	Ultimate Commercial Door	10/31/2016: Added 9-0 Call number heights for Ultimate Commercial Doors with wood frames.
2017	Ultimate Commercial Door	04/24/2017: Discontinued the steel frame.
	All Commercial Doors	10/30/2017: Added prep option for Von Duprin 5547 hardware for the 2 1/4inch Commercial door and a prep option for the Sargent 8200 series hardware for both the 1 3/4 and 2 1/4inch Commercial doors.
2022	All Commercial Doors	8/29/2022: Gold Anodized sill options are no longer available and have been moved to Disc NA. See Product Bulletin 842 for more information.
2023	Ultimate and Ultimate Wood Commercial Door	06/26/2023: Updated glazing bead profiles for Direct Glaze Polygons, Round Tops and Direct Glaze Transoms. See Product Bulletin 887 and 891 for more information.
2024	Ultimate and Ultimate Wood Commercial Door	10/28/2024: Direct Glaze Transoms will now be referred to as Direct Glaze Rectangles. See Product Bulletin 950 for more information.

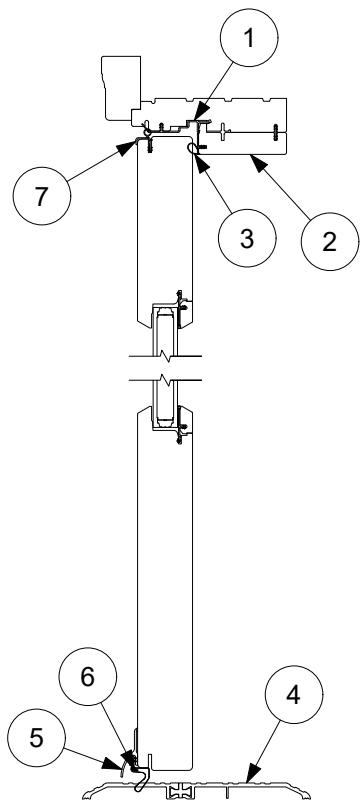

Head Jamb  
and Sill

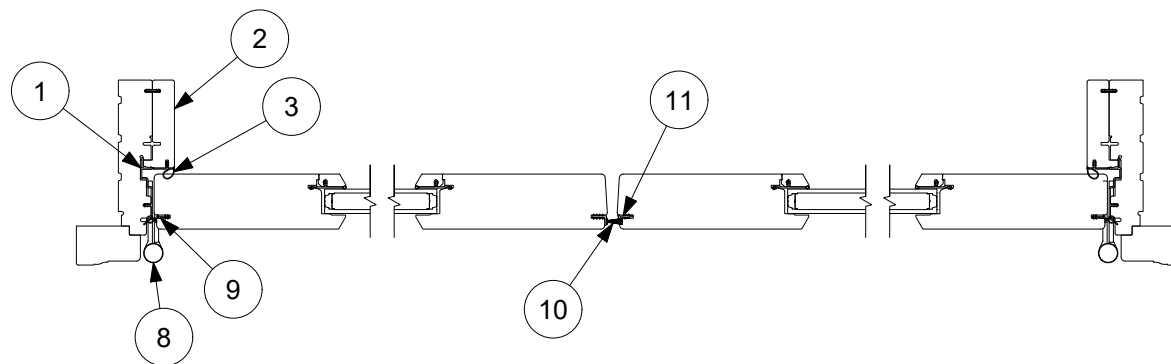

Jamb XX

- |                                       |   |
|---------------------------------------|---|
| 1. Head Jamb/Jamb Weather Strip, V017 | 7. Panel Cover Weather Strip, V018          |
| 2. Head Jamb/Jamb Parting Stop, W6000 | 8. 4 1/2" x 4 1/2" Ball Bearing Hinge       |
| 3. Offset Bulb Weather Strip, V796    | 9. Stile Weather Strip, V020                |
| 4. Standard Sill                      | 10. Weather Strip, 1/2" Pile, Offset, V2791 |
| 5. Panel Drip, A2408                  | 11. Wedge Frame Spacer, V2421               |
| 6. Panel Weather Strip, V3020         |   |

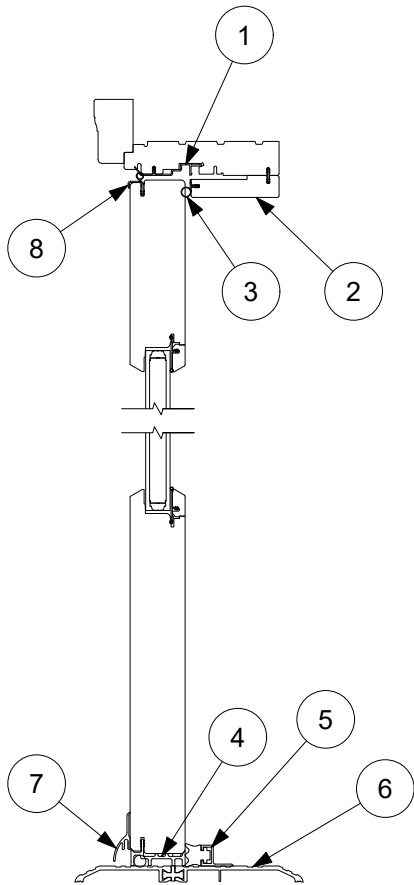

Head Jamb  
and Sill

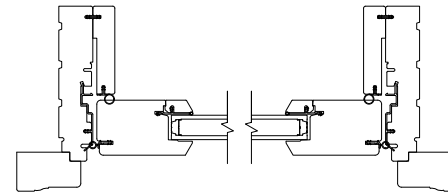

Jamb Sidelite  
Jamb O

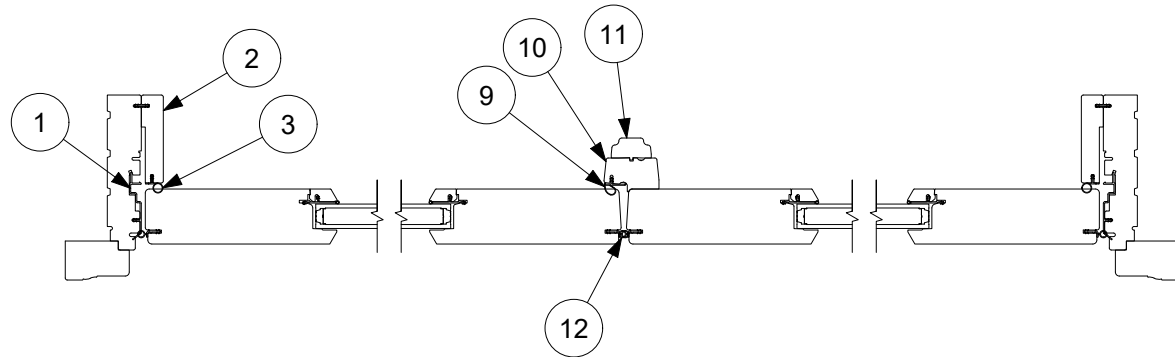

Stationary Jamb OO

1. Frame Weather Strip, V017
2. Head Jamb/Jamb Parting Stop, Stationary, W9475
3. Bulb Weather Strip, V192
4. Stationary Sill Sweep, V779
5. Gasket Stop, Stationary
6. Standard Sill

7. Panel Drip, A2408
8. Panel Cover Weather Strip, V018
9. Offset Bulb Weather Strip, V796
10. Mull Casing Base, W1455
11. Mull Casing Cover, W7554
12. Stile Weather Strip, V020

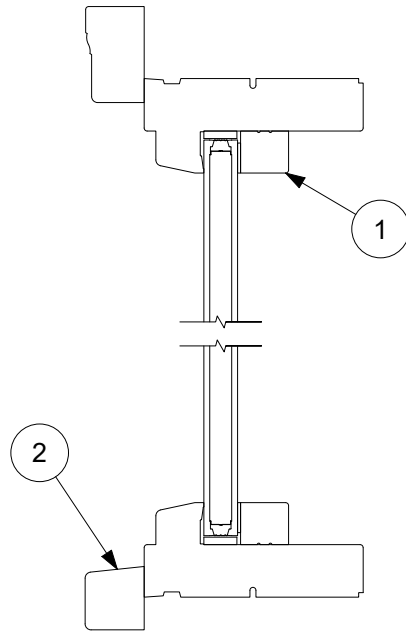

Head Jamb and Sill

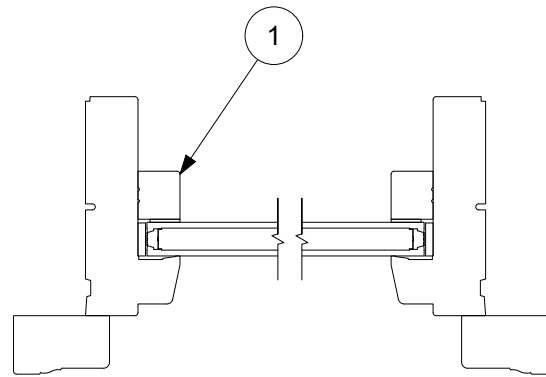

Jamb

1. Glazing Bead, W14258 (replaces W11751)
2. Sill Nose, W12059

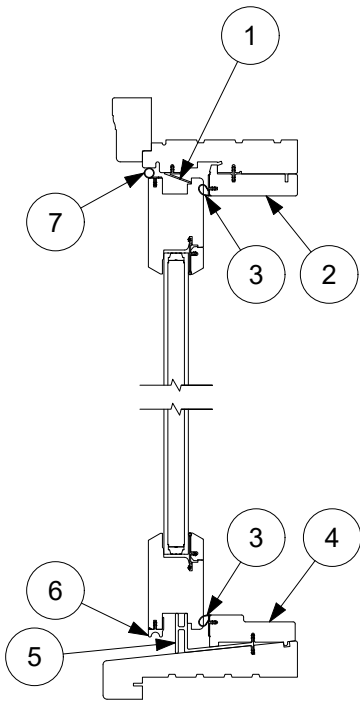

Head Jamb  
and Sill

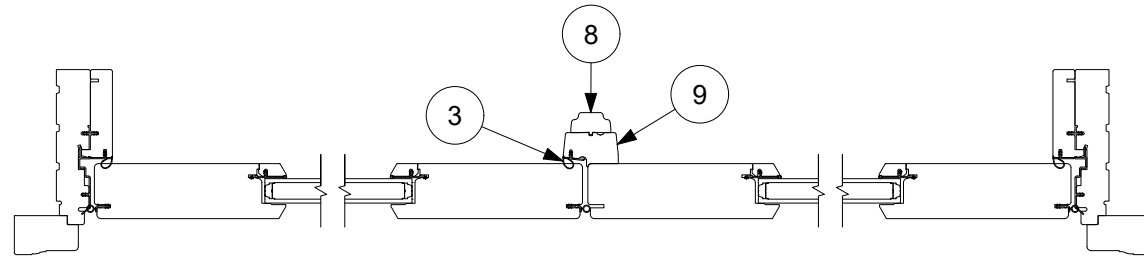

Jamb

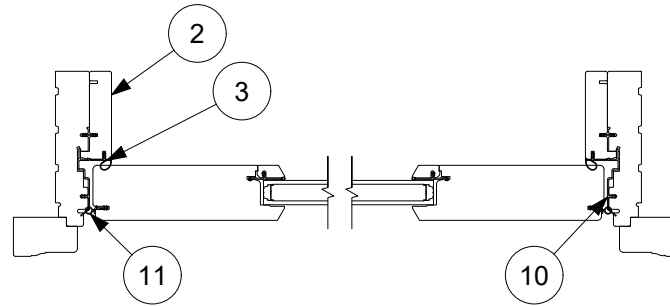

1. Sash Retainer, V026
2. Head Jamb/Jamb Parting Stop, W6000
3. Offset Bulb Weather Strip, V796
4. Sill Cover, W2136
5. Sill Leveling Block, V027
6. Panel Drip, V800

7. Bulb Weather Strip, V192
8. Mull Casing Cover, W7554
9. Mull Casing Base, W1455
10. Frame Weather Strip, V017
11. Stile Weather Strip, V020

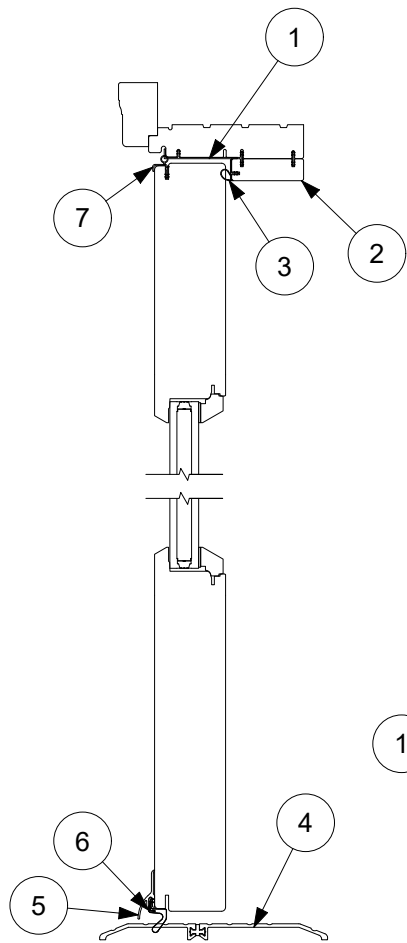

Head Jamb  
and Sill

1. Frame Weather Strip, V1707
2. Head Jamb/Jamb Parting Stop, W10401
3. Offset Bulb Weather Strip, V796
4. Standard Sill
5. Panel Drip, A2408
6. Panel Weather Strip, V3020

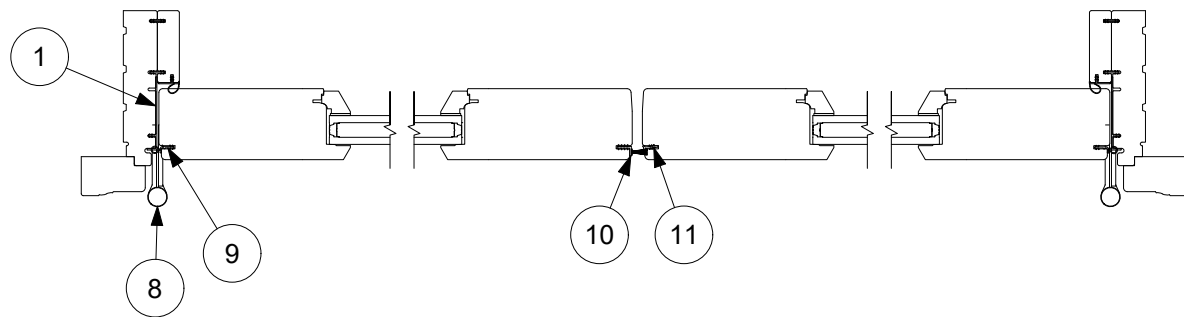

Jamb XX

7. Panel Cover Weather Strip, V018
8. 4 1/2" x 4 1/2" Ball Bearing Hinge
9. Stile Weather Strip, V020
10. Pile Weather Strip, V2791
11. Wedge Frame Spacer, V2421

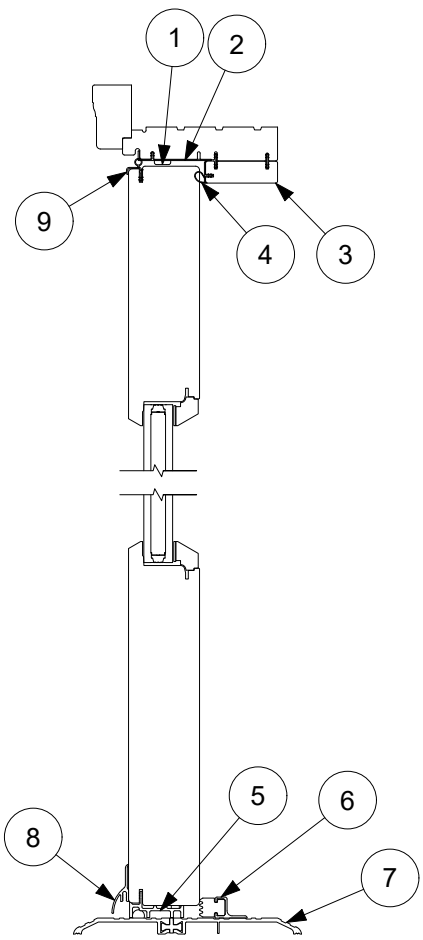

Head Jamb and Sill

- 1. Head Jamb Spacer Tack
- 2. Frame Weather Strip, V1707
- 3. Head Jamb/Jamb Parting Stop, W10401
- 4. Offset Bulb Weather Strip, V796
- 5. Stationary Sweep. V779
- 6. Gasket Stop, Stationary
- 7. Standard Sill

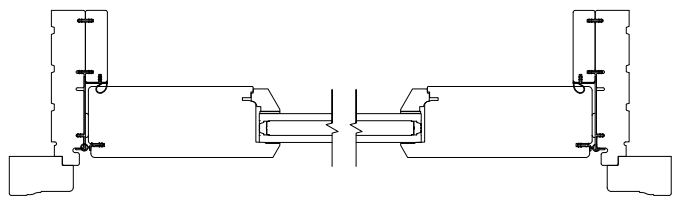

Stationary Jamb

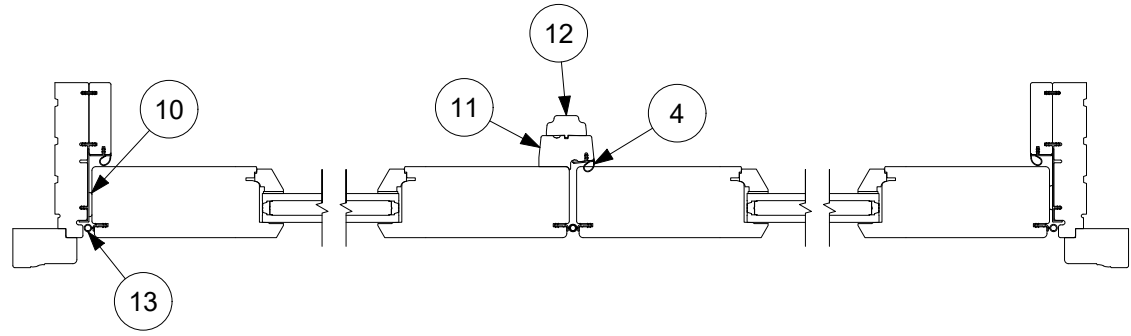

- 8. Panel Drip, A2408
- 9. Panel Cover Weather Strip, V018
- 10. Jamb Spacer Tack
- 11. Mull Casing Base, W1455
- 12. Mull Casing Cover, W7554
- 13. Stile Weather Strip, V020



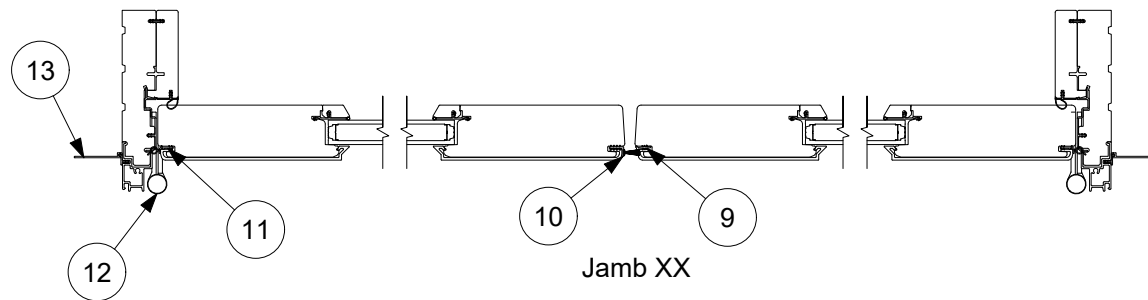
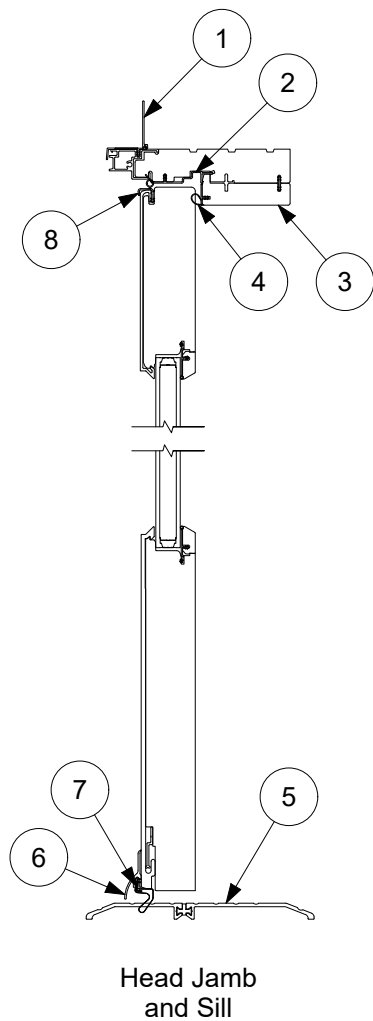

- 1. Head Jamb Nailing Fin/Drip Cap, V119
- 2. Frame Weather Strip, V017
- 3. Head Jamb/Jamb Parting Stop, W6000
- 4. Offset Bulb Weather Strip, V796
- 5. Standard Sill

- 6. Panel Drip, A2408
- 7. Panel Drip Weather Strip, V3020
- 8. Panel Cover Weather Strip, V018
- 9. Wedge Frame Spacer, V2421

- 10. Pile Weather Strip, V2791
- 11. Stile Weather Strip, V020
- 12. 4 1/2" x 4 1/2" Ball Bearing Hinge
- 13. Jamb Nailing Fin, V104

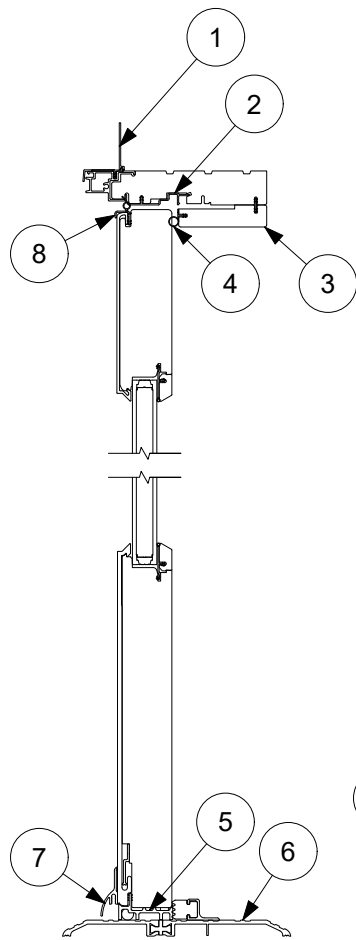

Head Jamb and Sill

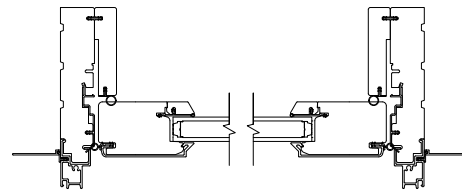

Sidelite Jamb

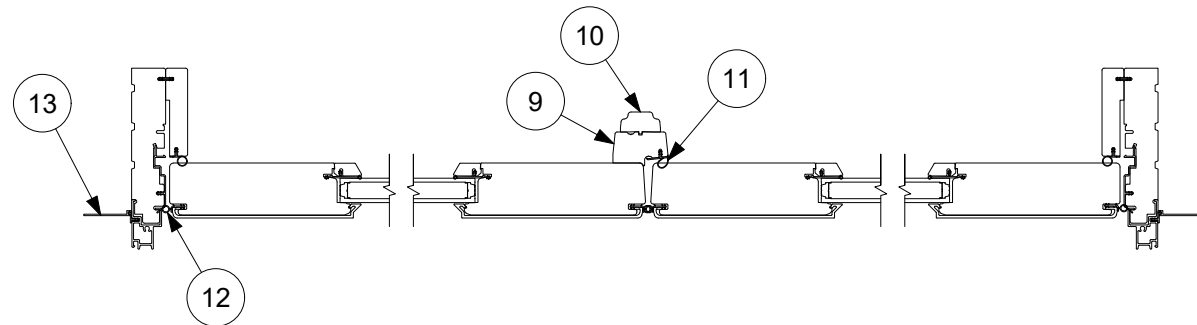

Stationary Jamb

- |  |                                     |
|--|-------------------------------------|
| 1. Head Jamb Nailing Fin/Drip Cap, V119            | 8. Panel Cover Weather Strip, V018  |
| 2. Frame Weather Strip, V017                       | 9. Mull Casing Base, W1455          |
| 3. Head Jamb/Jamb Parting Stop, W9475              | 10. Mull Casing Cover, W7554        |
| 4. Head Jamb/Jamb Parting Stop Weather Strip, V192 | 11. Offset Bulb Weather Strip, V796 |
| 5. Stationary Sweep, V779                          | 12. Stile Weather Strip, V020       |
| 6. Standard Sill                                   | 13. Jamb Nailing Fin, V104          |
| 7. Panel Drip, A2408                               |                                     |

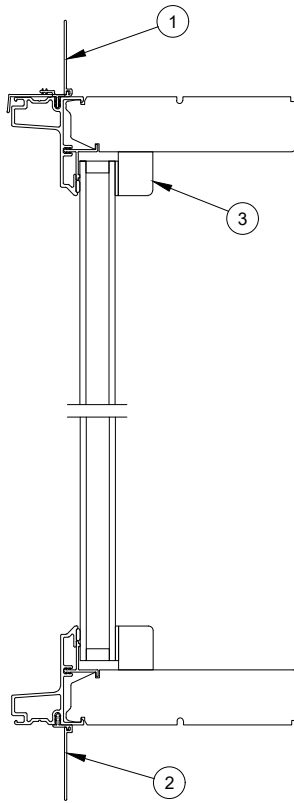

Head Jamb And Sill Detail

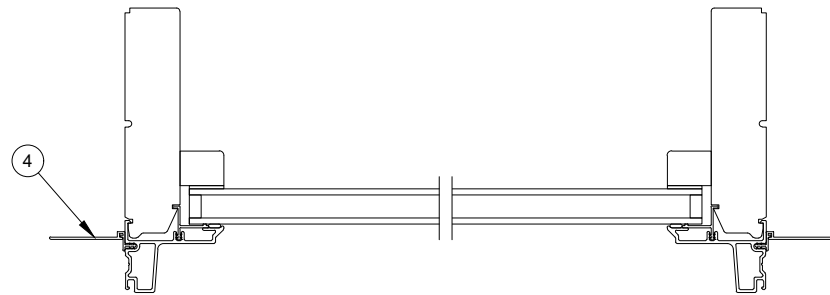

Jamb Detail

1. Head Jamb Nail Fin/Drip Cap, V119
2. Sill Nailing Fin, V104
3. Glazing Bead, W14258 (Replaces W11751)
4. Jamb Nailing Fin, V104

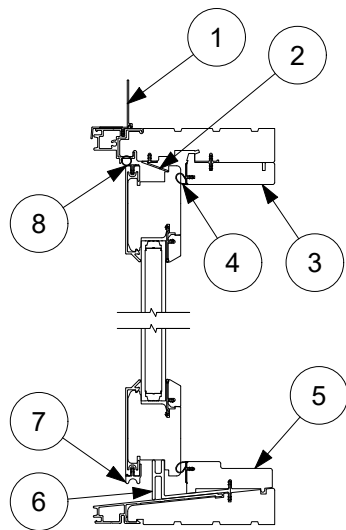

Head Jamb  
and Sill

1. Head Jamb Nail Fin/Drip Cap, V119
2. Sash Retainer, V026
3. Head Jamb/Jamb Parting Stop, W6000
4. Offset Bulb Weather Strip, V796
5. Sill Cover, W2136
6. Sill Leveling Block, V027
7. Panel Drip, V800

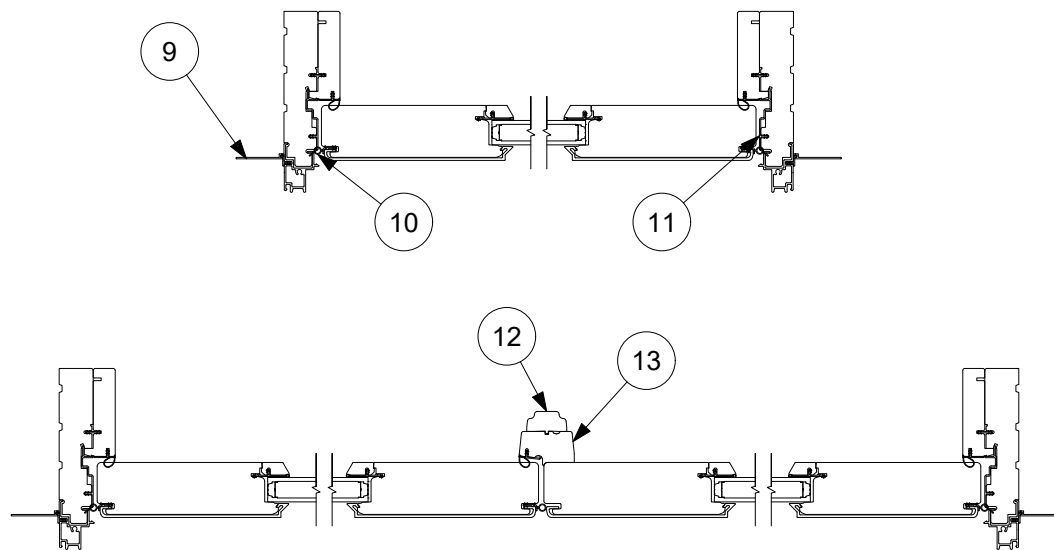

Jamb

8. Bulb Weather Strip, V192
9. Jamb Nailing Fin, V104
10. Stile Weather Strip, V020
11. Frame Weather Strip, V017
12. Mull Casing Cover, W7554
13. Mull Casing Base, W1455

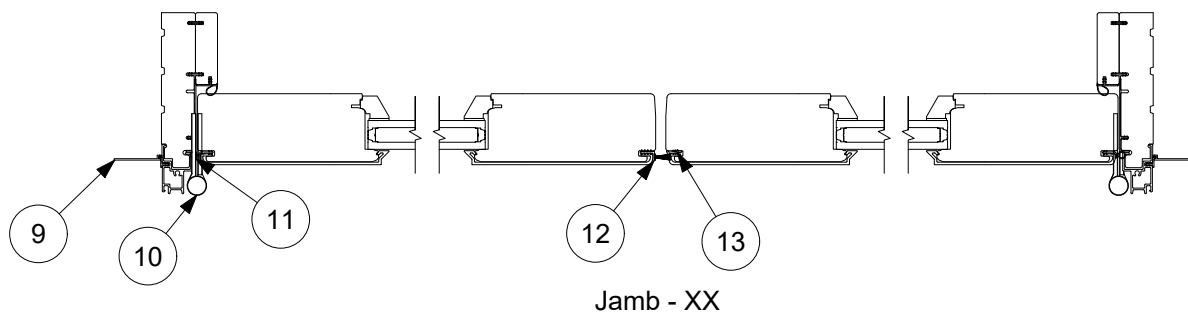
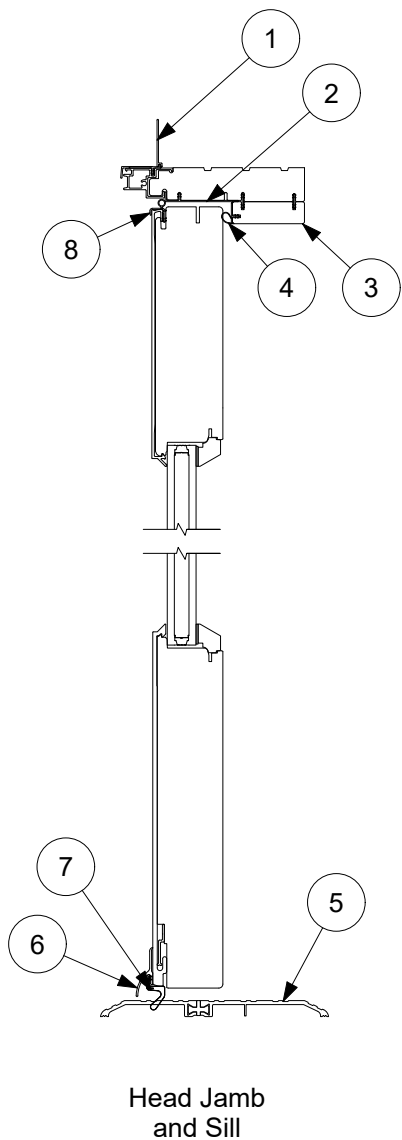

1. Head Jamb Nailing Fin/Drip Cap, V119
2. Frame Weather Strip, V1707
3. Head Jamb/Jamb Parting Stop, W10401
4. Offset Bulb Weather Strip, V796
5. Standard Sill

6. Panel Drip, A2408
7. Panel Weather Strip, V3020
8. Panel Cover Weather Strip, V018
9. Jamb Nailing Fin, V104

10. 4 1/2" x 4 1/2" Ball Bearing Hinge
11. Stile Weather Strip, V020
12. Pile Weather Strip, V2791
13. Wedge Frame Spacer, V2421

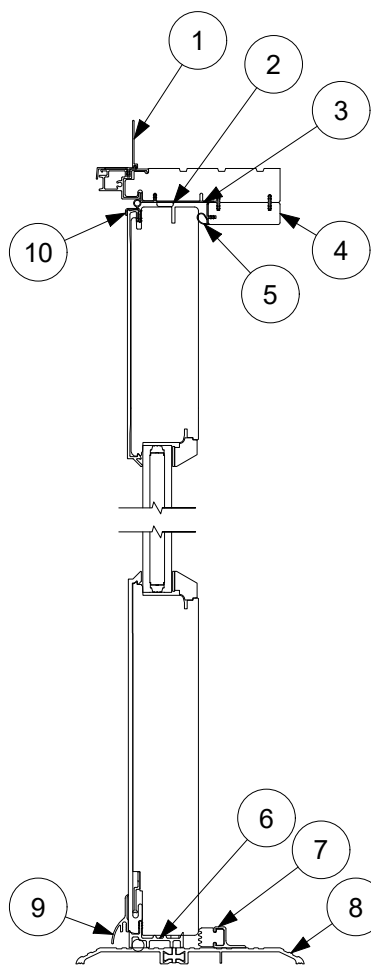

Head Jamb and Sill

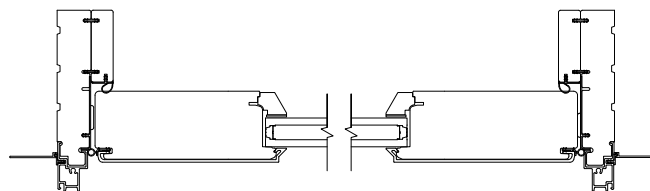

Sidelite Jamb

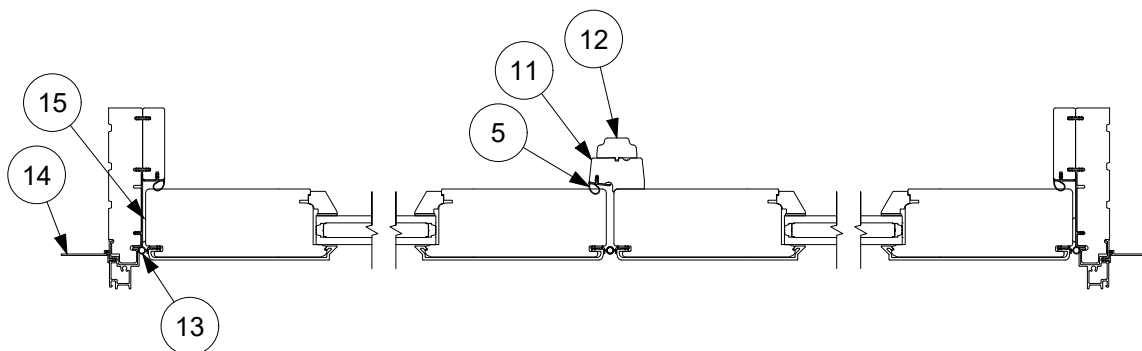

Stationary Jamb

- 1. Head Jamb Nailing Fin, V119
- 2. Header Spacer Tack
- 3. Frame Weather Strip, V1707
- 4. Head Jamb/Jamb Parting Stop, W10401
- 5. Offset Bulb Weather Strip, V796

- 6. Stationary Sweep, V779
- 7. Gasket Stop, Stationary
- 8. Standard Sill
- 9. Panel Drip, A2408
- 10. Panel Cover Weather Strip, V018

- 11. Mull Casing Base, W1455
- 12. Mull Casing Cover, W7554
- 13. Stile Weather Strip, V020
- 14. Jamb Nailing Fin, V104
- 15. Jamb Spacer Tack

## 4 1/2" x 4 1/2" Ball Bearing Hinge

### Includes:

- 1 - Hinge
- 6 - #12 x 1" Phillips flat head wood screw
- 2 - #12 x 2 1/2" Phillips flat head screw

NOTE: Hinge color/part number includes the color matched screws. If you need to order the screws separately, they are listed below aligned with the corresponding hinge color.

Screw Description	Hinge Color	PN	Screw Color	PN
#12 x 1" Phillips flat head wood screws Satin Chrome-US26D, Bronze-US10A Brass-US3, Stainless Steel-US32D	Stainless Steel	02100162	Stainless Steel	02056069
	Satin Chrome brass	02101166	Stainless Steel	02056069
	Bronze brass	02101167	Dark Bronze	02056010
	Brass brass	02101165	Brass	02056068
#12 x 2 1/2" Phillips flat head wood screws Satin Chrome-US26D, Bronze-US10A Brass-US3, Stainless Steel-US32D	Stainless Steel	02100162	Stainless Steel	02010311
	Satin Chrome brass	02101166	Stainless Steel	02010311
	Bronze brass	02101167	Dark Bronze	02056067
	Brass brass	02101165	Brass	02010310

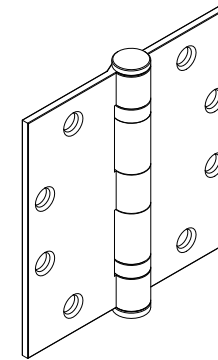

## Head or Foot Flush Bolt - Inactive Panel

Color	PN
Black	11101780

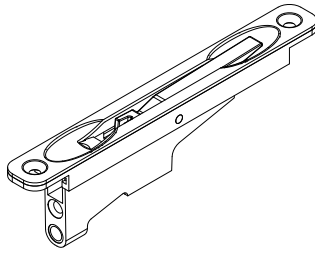

## Cover Plate for Flush Bolt

### Includes:

2 - #8 x 1" screw (11800645)

Color	PN
Aluminum	11860402

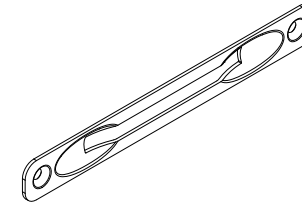

## Inactive Panel Locking Rod Assembly Top or Bottom Flush Bolt (XX)

### Includes:

1 - Locking rod with end bolt

Description	CN Height	Length	Color	PN
Top Locking Rod	7-0	11"	Stainless Steel	05700180
	8-0	27"		05700185
	9-0	34 1/4"		05700170
	10-0	51"		05700196
Bottom Locking Rod	--	11"	Stainless Steel	10815178

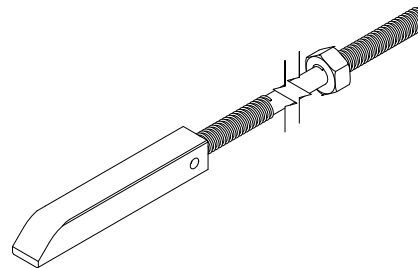



## Shoot Bolt Guide - Inactive Panels

### Includes:

- 1 - Shoot bolt guide (10815186)
- 1 - #8 x 1 1/2" Phillips pan head wood screw (11800766)

PN
10815199

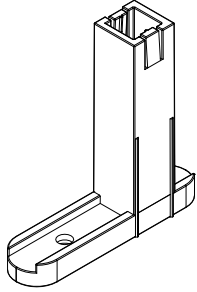

## Strike Plate, Head Jamb

### Includes:

- 2 - #8 x 1" Phillips truss head wood screw (11800915)
- 2 - #8 x 3" Truss head, Stainless Steel screw (11800832)

Color	PN
Beige	05700315
Bronze	05700316

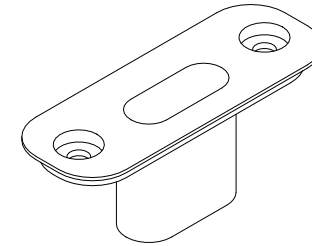

## Head Jamb Spacer Tack (Stationary Panel)

PN
11860424

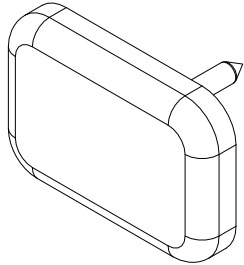

## Jamb Spacer Tack (Stationary Panel)

PN
11860423

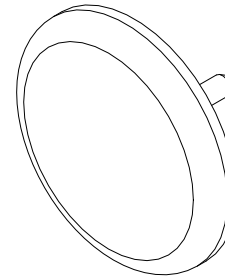

## Stationary Bracket (1 3/4" Door)

### Includes:

3 - #8 x 1" flat head screw (11800645)

PN
11100212

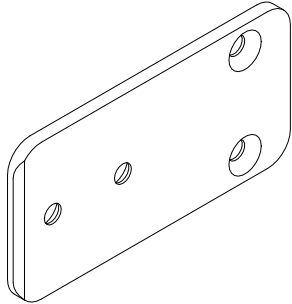

## Stationary Bottom Bracket

### Includes:

1 - #8 x 1 1/2" pan head screw (11865159)

1 - #6 x 1/4" pan head screw (02056061)

PN
02101168

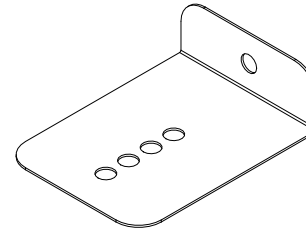

## Stationary Bracket, Jamb/Head Jamb

### Includes:

4 - #8 x 1" flat head screw (11800645)

2 - #7 x 1/4" flat head screw (11800760)

PN
02101169

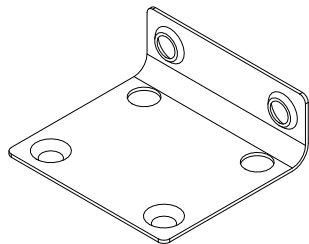

## Kick Plate

### Includes:

16 - #6 x 5/8" truss head SMS screw

(Stainless Steel-US32D, Bronze-US10B, Brass-US4)

CN Height	Color	PN
3-0	Stainless Steel	10148094
	Brass	10148095
	Bronze	10148096
3-6	Stainless Steel	18900457
	Brass	18900453
	Bronze	18900455
4-0	Stainless Steel	18900452
	Brass	18900454
	Bronze	18900456

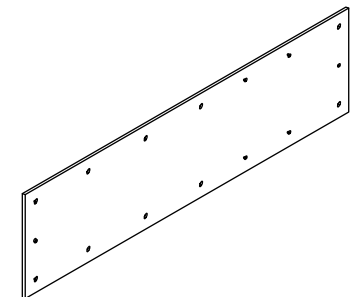

## Panel Drip Pkg Information

Usage dates: July 30, 2012 - Present

NOTE: A2408 Panel drip is available in the Ultimate and Ultimate Wood Accessories section by individual part number.

It is recommended to replace the panel drip weather strip (V3020) when replacing the panel drip.

Ultimate Commercial Door: Panel drip and screws will match standard exterior color. For custom colors, screws will be stainless steel.

Ultimate Wood Commercial Door: Panel Drip defaults to match sill color.

## Panel Drip Pkg, Ultimate

Usage dates: July 30, 2012 - Present

### Includes:

A2408, panel drip (panel drip and screws will match exterior color)

V3020, panel weather strip

Foam tape

#6 x 1 1/4" pan head screws

CN	Bronze PN
1-6	11100264
3-0	11100265

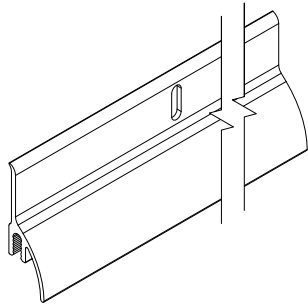

A2408

## Panel Drip Pkg, Ultimate Wood

Usage dates: July 30, 2012 - Present

### Includes:

A2408, panel drip

V3020, panel weather strip

#6 x 1 1/4" pan head screws

CN	Beige PN	Bronze PN	Clear PN
1-6	11100260	11100264	11100268
3-0	11100261	11100265	11100269
3-6	11100262	11100266	11100270
4-0	11100263	11100267	11100271

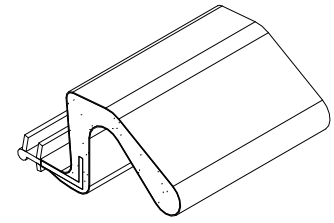

V3020

## Gasket Stop

Stationary Door

Length	Color	PN
185"	Mill Finish	18450503
	Dark Bronze	18450501
	Gold	18450502

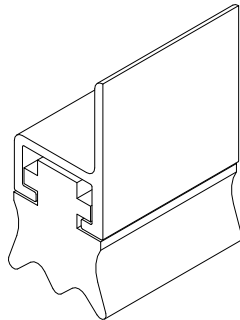

## Gasket Stop Fastener

#6 x 1/4" Phillips pan head screw

Color	PN
Mill Finish	02056061
Dark Bronze	02056062
Gold	02056063

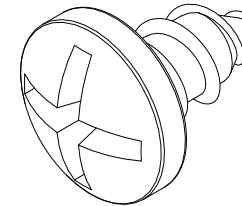

# Panel Drip Pkg, Ultimate Wood

Usage dates: Pre-July 30, 2012

CN	Mill Finish PN	Dark Bronze PN	Gold PN
1-6	18451216	18451316	18451416
3-0	18451139	18451140	18451430
3-6	18451236	18451336	18451436
4-0	18451240	18451340	18451440

Suggested Fasteners		
#6 x 1 1/4" Phillips pan head screw		
Mill Finish PN	Dark Bronze PN	Beige PN
02056064	02056065	02056070

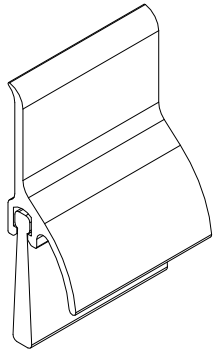

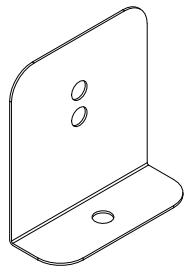

**Stationary Bottom Bracket**  
No longer available, replace with current.

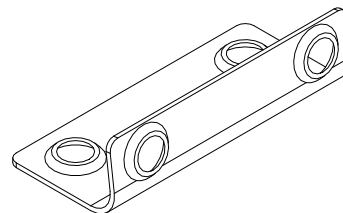

**Stationary Bracket**  
No longer available, replace with current.

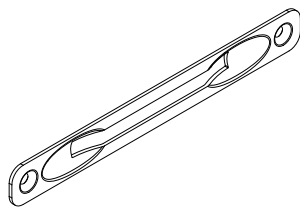

**Cover Plate for Flush Bolt**  
Brass and Antique Brass PVD  
No longer available

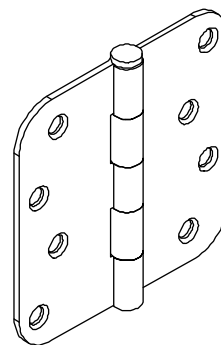

**Ball Bearing Hinge**  
Outswing Light Commercial Door DISC-NA 2005  
Solid Brass and Satin Chrome  
No longer available

**Ordering specifications (use all that apply):**

1. Original order number/line number (if available)
2. Profile
3. Rough opening
4. Length
5. Handing
6. Finish/color (where applicable)

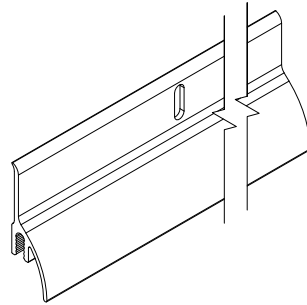

**A2408  
Panel Drip**

**Ordering specifications (use all that apply):**

1. Original order number/line number (if available)
2. Profile
3. Rough opening
4. Length
5. Handing
6. Finish/color (where applicable)

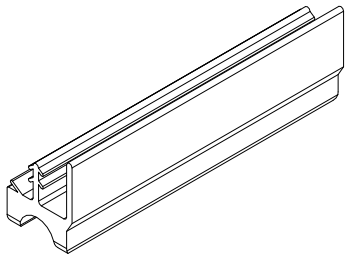

**V800**  
**Panel Drip**

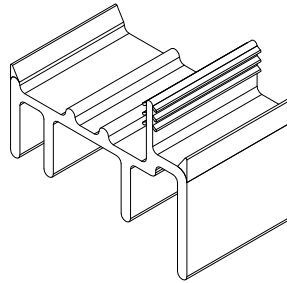

**V779**  
**Stationary Sweep**

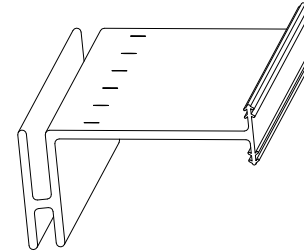

**V027**  
**Sill Leveling Block**

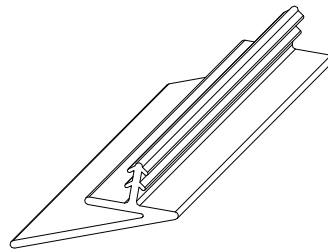

**V026**  
**Sash Retainer**

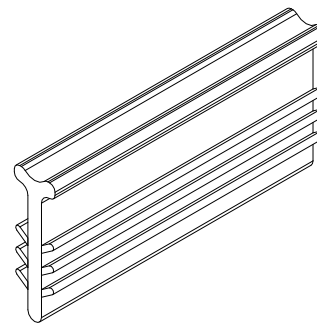

**V2421**  
**Wedge Frame Spacer**

## Wood Parts

### Ordering specifications (use all that apply):

1. Original order number/line number (if available)
2. Profile
3. Rough opening
4. Length
5. Handing
6. Finish

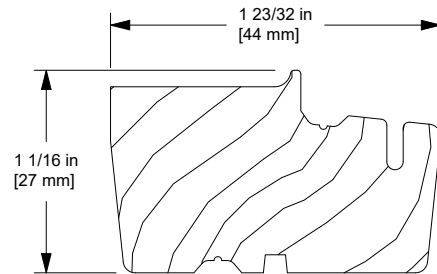

**W1455**  
**Mull Casing Base**

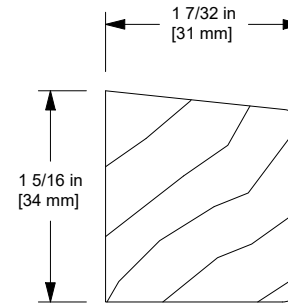

**W12059**  
**Sill Nosing**

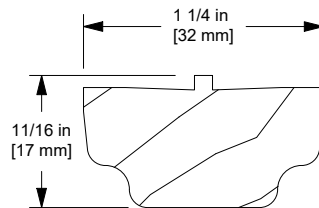

**W7554**  
**Mull Casing Cover**

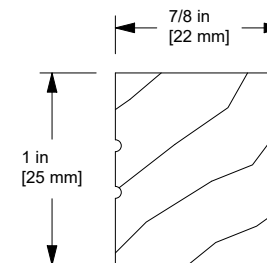

**W14258**  
**Glazing Bead, IG**  
Direct Glaze Rectangle



**Ordering specifications (use all that apply):**

1. Original order number/line number (if available)
2. Profile
3. Rough opening
4. Length
5. Handing
6. Finish

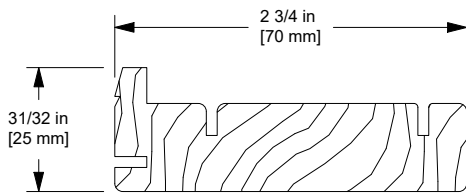

**W6000**  
**Head Jamb/Jamb Parting Stop**  
Operator and In-Sash Transom

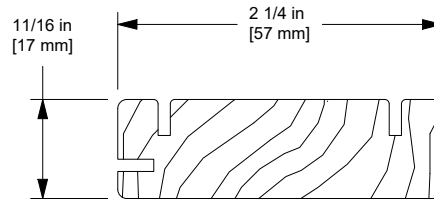

**W10401**  
**Head Jamb/Jamb Parting Stop**  
2 1/4 Door

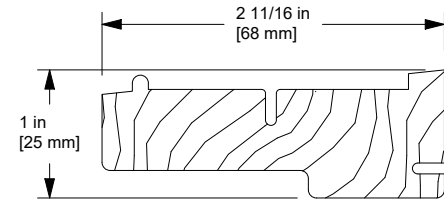

**W2136**  
**Head Jamb/Jamb Parting Stop**  
Operator and In-Sash Transom

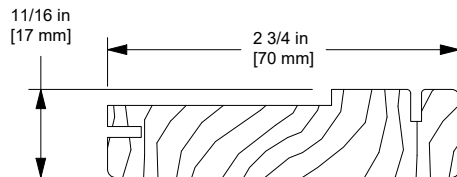

**W9475**  
**Head Jamb/Jamb Parting Stop**  
Stationary

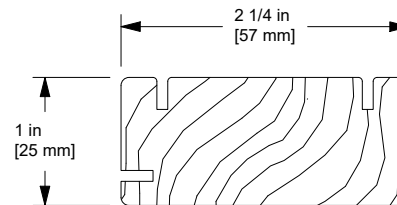

**W12095**  
**Head Jamb Stop**  
2 1/4" Door  
(use with Von Duprin 5547 Hardware Prep)

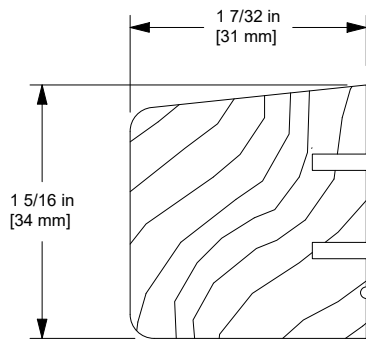

**W8653, Sill Nosing**  
Used prior to 6/24/2013

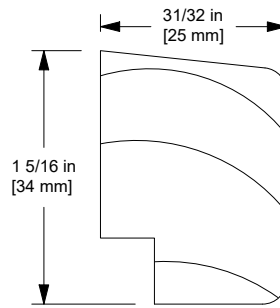

**W12031, Sill Nosing**  
**Direct Glaze Rectangle**  
(Total R.O. Continuous Casing)  
Pre-2011

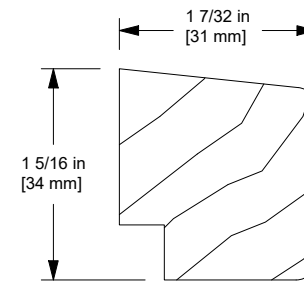

**W12032, Sill Nosing**  
**Direct Glaze Rectangle**  
Pre-2011 - Split Casing

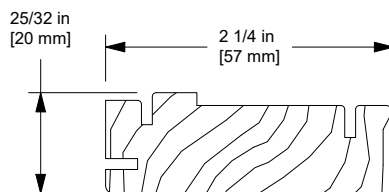

**W8986**  
**Head Jamb/Jamb Stop**  
**2 1/4" Door**  
No longer available  
Used prior to 3/30/2009

## Offset Bulb Weather Strip

V796

Used on Parting Stop, Frame, Mull Casing, In-Sash Transom and Astragal

Length	Color	PN
75 43/64"	Beige	15170866
	Black	15170867
104 7/8"	Beige	15170090
	Black	15170091
115 41/64"	Beige	15170810
	Black	15170811
189 23/32"	Beige	15173298
	Black	15173398

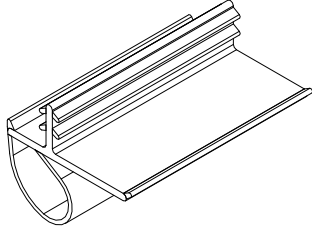

## Stile Weather Strip

V020

Length	Color	PN
79 9/16"	Beige	11197968
92 15/16"	Beige	11197982
150"	Beige	11197999
	Black	11197998

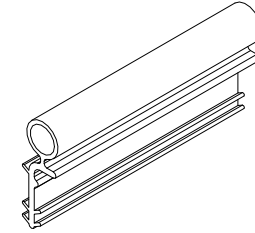

## Frame Weather Strip

V017

Length	Color	PN
41 15/16"	Beige	11197536
80 5/8"	Beige	11198668
94 1/8"	Beige	11198682
164 7/8"	Beige	11197596
	Black	11197598

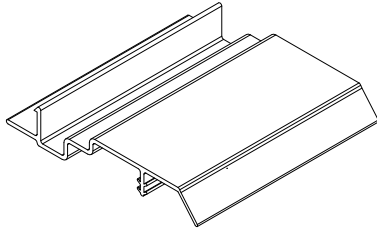

## Panel Cover Weather Strip

V018

Length	Color	PN
150"	Beige	11198799
	Black	11198999

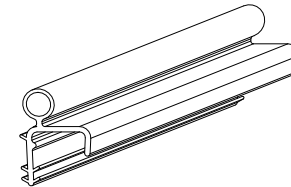

## Frame Weather Strip

V1707

Used on 2 1/4" Doors

Length	Color	PN
120"	Beige	11191299
	Black	11191399

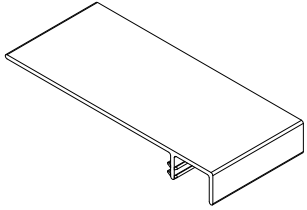

## Bulb Weather Strip

V3020

Length	Color	PN
84"	Beige	11195405
97"		11195410
120"		11195415
85"	Black	11195420
97"		11195425
120"		11195430
85"	Bronze	11195435

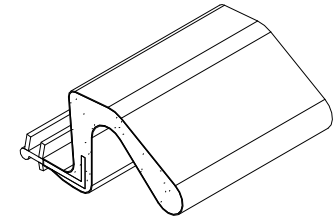

## Bulb Weather Strip

V192

Used on In-Sash Transom Top Rail

Length	Color	PN
84"	Beige	15900058
192"	Beige	15900118
	Black	15900117

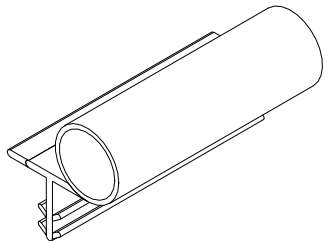

**Ordering specifications (use all that apply):**

1. Original order number/line number (if available)
2. Profile
3. Rough opening
4. Length
5. Handing
6. Finish/color (where applicable)

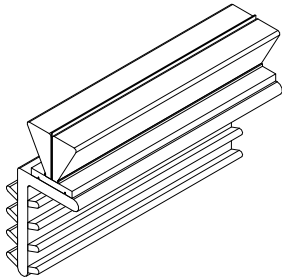

**V2363**  
**Pile Weather Strip,  
Locking Stile**

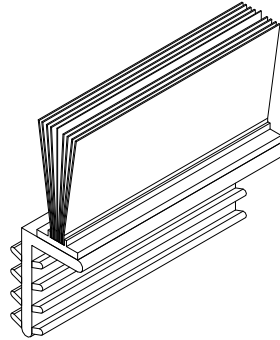

**V2791**  
**Pile Weather Strip**

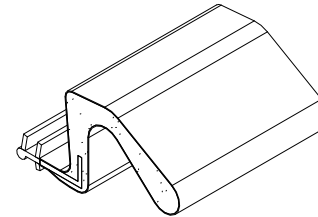

**V3020**  
**Panel Weather Strip**

# Frame Weather Strip

V1296

Used on 2 1/4" Doors

Length	Color	PN
120"	Beige	
	Black	

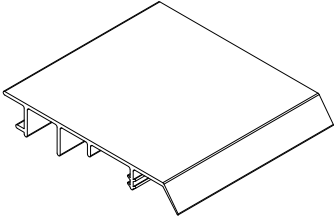

## Schalge L Series Mortise Lock with /06 Lever

"L" Escutcheon and Strike:  
Entrance (L9453)  
Keyed Exterior  
Interior with Thumb Turn

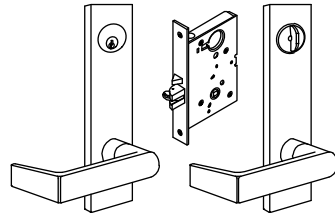

## Schalge L Series Mortise Lock with /06 Lever

"L" Escutcheon and Strike:  
Corridor  
Keyed Exterior  
Interior (no Thumb Turn)

## Dummy Trim, Von Duprin (98-990-DT)

Rigid lever for pull operation

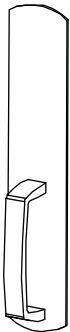

## Lever Night Latch, Von Duprin (98-996L-NL)

Rigid lever  
Key retracts latch bolt

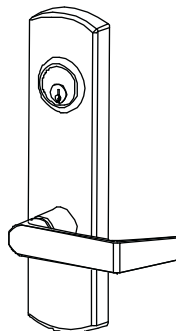

## Dummy Trim Night Latch, Von Duprin (98-990-NL)

Rigid Lever  
Key retracts latch bolt

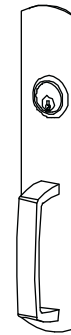

## Lever, Dummy Trim, Von Duprin (98-996L-DT)

Rigid lever for pull operation

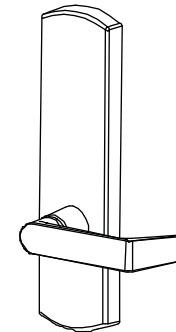



## Removable Mullion Keyed or Non-Keyed

(AL-SP28)  
(BZ-SP313)



## Rim (Panic) Device, Lever, Von Duprin 96L

(SC-US26D)  
(BZ-313AN)  
(BS-US3)

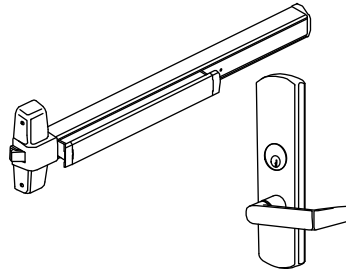

## Rim (Panic) Device, Exit Only, Von Duprin 98EO

(SC-US26D)  
(BZ-313AN)  
(BS-US3)

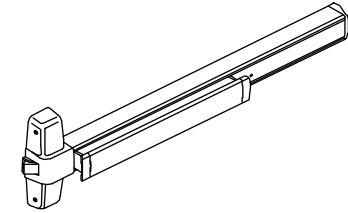

## Closer, 2 1/4Inch Door

LCN4041  
(AL-BHMA689)  
(BZ-BHMA695)  
(BS-BHMA696)

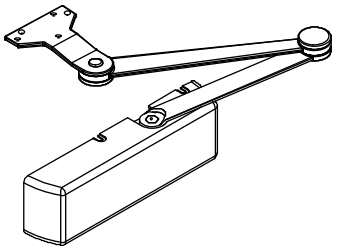

## Closer

LCN1461  
(AL-BHMA689)  
(BZ-BHMA695)  
(BS-BHMA696)

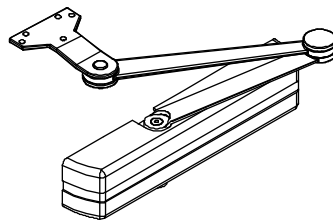

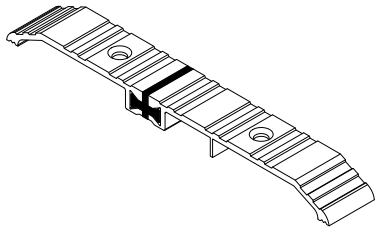

**1/2" Sill (Profile#253) Standard Sill**  
 Pemko Model 253X4AFG  
 (Anodized Aluminum)  
 Options: 253X4DFG (Dark Bronze)

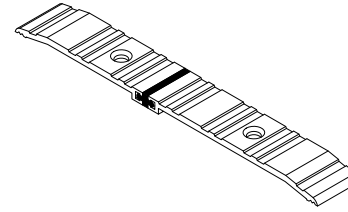

**1/4" Sill (Profile#273)**  
 Thermal Barrier Threshold  
 Pemko models:  
 273X4AFG and 273X4DFG

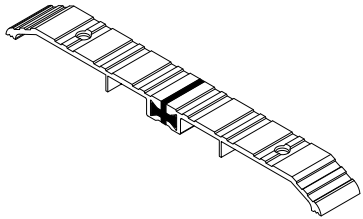

**1/2" Sill**  
 Pemko Models:  
 254X4AFG and 254X4DFG

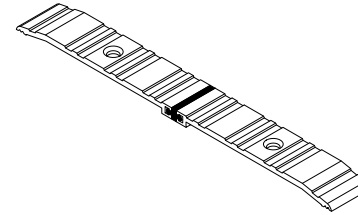

**1/4" Sill**  
 Pemko models:  
 274X4AFG and 274X4DFG

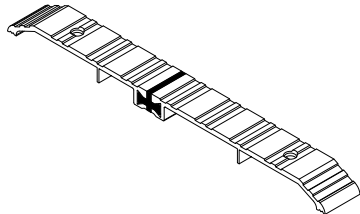

**1/2" Sill**  
 Pemko Models:  
 254X5AFG and 254X5DFG

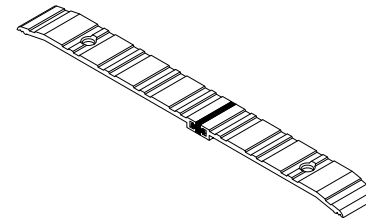

**1/4" Sill**  
 Pemko models:  
 274X6AFG and 274X6DFG

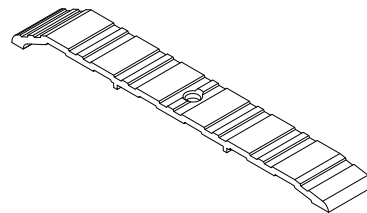

**Offset Sill (Profile#2727)**  
 Offset Saddle Threshold  
 Pemko models:  
 2727A and 2727D

Refer to OMS Configured Parts for Panel Replacement options.

**Ordering specifications (use all that apply):**

1. Original order number/line number (if available)
2. Exterior finish
3. Size (call number or OM of panel)
4. Active, inactive or stationary
5. Specify bore or no bore
6. Handing
7. Glazing
8. Finish